

Felistyle

HOME INTERIOR COMFORT GUIDE

MADE IN ITALY



Over 200 models of sofas, armchairs and convertibles

Really various

New models, revealed now

Felistyle

HOME INTERIOR COMFORT GUIDE

Really various

New models, revealed now



Felis Style vuole essere un tributo al gusto italiano nell'uso del colore, negli abbinamenti, nella scelta dei complementi d'arredo. A guidarci sono grandi architetti, pensatori, filosofi che hanno raccontato cosa significa "casa", "design" e "bellezza". Sfoglia le pagine di questa rivista e immergiti nel mondo Felis: troverai tanti divani dalle linee uniche ma soprattutto tanti consigli per arredare con buon gusto il tuo living.

Felis Style is a tribute to the Italian taste in the use of color, in the combinations, in the choice of furnishings. We are guided by great architects, thinkers, philosophers who told what "home", "design" and "beauty" mean. Browse the pages of this magazine and immerse yourself in the Felis world: there you will find lots of sofas with unique lines but also many tips for decorating your living area with taste.

Felis Style souhaite rendre hommage au style italien pour ses couleurs, ses combinaisons et le choix des composants d'ameublement. Pour nous guider, nous faisons appel aux grands architectes, penseurs et philosophes ayant donné une définition aux mots « maison », « design » et « beauté ». Feuilletez ce magazine et plongez dans le monde Felis : vous y trouverez de nombreux canapés aux lignes uniques mais également de nombreux conseils pour décorer votre salon.

ITALIAN
QUALITY®
QUALITÀ PRODOTTA IN ITALIA

LIVING

Discover the
italian style



EROS 4



GINGER 14



FRED 20



DEREK 30



ARON 38



LEON 46



ALLISON 52



VINCENT 62



JASPER 68



RUSSEL 78



DOMINO 86



MAXIMÈ 92



BLOOM 98



NORMAN 106



PAPRIKA 114



NIKKO 120



MODÌ 126



EXTÈ 132



AIDA 138



ASCOT 142



GRAY 146



BOLERO 150

Sommario
Summary
Résumé

Listino al pubblico senza IVA - Prezzi esposti in categoria Super
Retail prices without VAT - prices shown are in Super category
Prix au public hors TVA - Les prix exposés sont pour la catégorie super

Listino prezzi a partire da pagina 257
Prices list from page 257
List de prix a partir de la page 257

DAY &
NIGHT



JACK 160



KURT 164



JIM 168



Over 200 models of sofas,
armchairs and convertibles



MICK 172



TOM 176



STEVE 180



MARK 184



BOB 188



SVEN 194



GRACE 198



JANIS 202



JHON 206



SPACE 214



FLAIR 218



ARIK 222



GIÒ 226



OPLÀ 232



POUF
E CUSCINI 236

EROS style

Uomo colto è colui che sa trovare un significato bello alle cose belle.
Those who find beautiful meanings in beautiful things are the cultivated..
L'homme cultivé est celui qui sait comment trouver le beau dans les belles choses. - Oscar Wilde

Il divano Eros recliner integra perfettamente tecnologia ed estetica in una sintesi ideale. L'esclusivo meccanismo Zero Wall in versione manuale o elettrica, permette di reclinare lo schienale e allungare la seduta in un unico movimento senza dover allontanare il divano dalla parete.

The Eros recliner sofa seamlessly integrates technology and aesthetics in an ideal synthesis. The unique Zero Wall mechanism, in the manual or electric version, allows you to recline the backrest and stretch the seat in a single movement, without need to move the sofa away from the wall.

Le canapé Eros Recliner propose une synthèse idéale de la technologie et de l'esthétique. Le mécanisme exclusif Zero Wall, en version manuelle ou électrique, permet d'incliner le dossier et d'allonger l'assise en un seul mouvement, sans avoir à éloigner le canapé du mur.



MECCANISMO ELETTRICO SENZA FILI WIRELESS

WIRELESS ELECTRICAL MECHANISM
MÉCANISME ÉLECTRIQUE **SANS FIL**

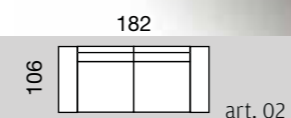

Versione **fissa** - **Fixed** version - Version **fixe**



Sedersi sul divano, senza avere il pensiero di sistemare il cuscino dietro la nostra testa o il poggiatesta per distendere bene le gambe. Eros Recliner è la soluzione intelligente per il tuo comfort. Scegli l'inclinazione ottimale e rilassati comodamente con un semplice click.

Sit on the sofa, without the need to place a pillow behind our head, or to use a foot rest to stretch your legs. Eros Recliner is the smart solution for your comfort. Choose the optimum tilt and relax comfortably with a simple click.

S'assoir sur le canapé, sans penser à devoir remettre en place le coussin derrière la tête ou le repose-pieds pour étendre les jambes. Eros Recliner est la solution intelligente pour votre confort. Choisissez l'inclinaison optimale et détendez-vous confortablement en un simple clic.

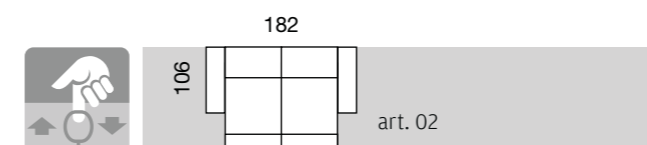

Seduta **manuale** - **Manual** seat - Assise **manuelle**

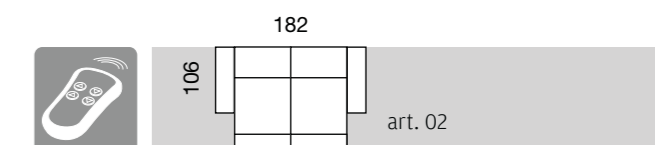

Seduta **elettrica** - **Electric** seat - Assise **électrique**

Il poggiatesta si integra perfettamente con la linea elegante del divano

The headrest fits in perfectly with the elegant line of the sofa

L'appui-tête s'inscrit parfaitement dans l'élégance de la ligne du canapé



Poggiatesta - Headrest
Appuie-Tête
art. 31 optional

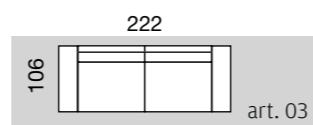

Versione **fissa** - **Fixed** version - Version **fixe**

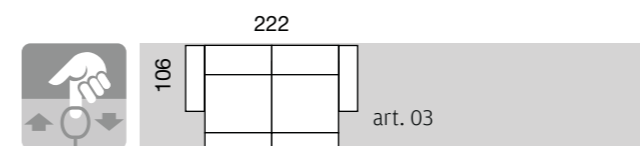

Seduta **manuale** - **Manual** seat - Assise **manuelle**

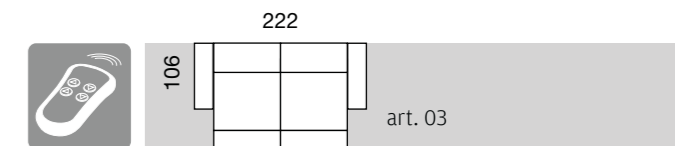

Seduta **elettrica** - **Electric** seat - Assise **électrique**

COMPLETE RELAX

ANCHE CON
IL PRATICO
MECCANISMO
MANUALE

Sei tra i tanti che tornano a casa dal lavoro, si cambiano, si mettono le pantofole e vanno a sedersi sul divano? Allora scegli Eros Recliner: sedersi, distendersi o dormire - a voi la scelta, sia nella versione elettrica sia in quella con meccanismo manuale, semplice e pratico.

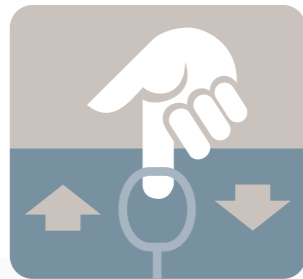

ALSO WITH THE PRACTICAL MANUAL MECHANISM

Are you among the many who go home from work, change their clothes, put on the slippers, and go sit on the sofa? Then choose Eros Recliner: you can sit, lie down, or sleep - the choice is yours, either in the electric or manual version, simple and practical.

ÉGALEMENT AVEC LE PRATIQUE MÉCANISME MANUEL

Faites-vous partie des nombreuses personnes qui rentrent du travail, se changent, enfilent leurs pantoufles et s'assoient sur le canapé? Alors choisissez Eros Recliner: s'asseoir, se détendre ou dormir - à vous de choisir, en version électrique ou avec mécanisme manuel, simple et pratique.

La casa è dove si trova il cuore.
Home is where the heart is.
La maison est là où se trouve le cœur. - Gaio Plinio Secondo

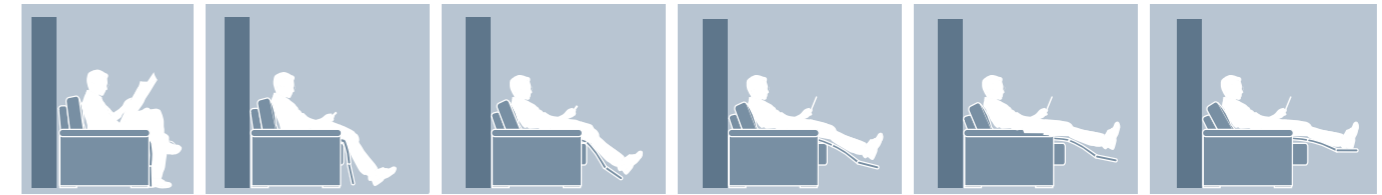

ZERO
WALL
System

Il sistema Zero Wall consente di non allontanare mai il divano dal muro. La soluzione perfetta per ottimizzare gli spazi, soprattutto quando sono ridotti e avere un comfort a portata di mano.

The Zero Wall system allows you to never move the sofa away from the wall. The perfect solution to maximize space, especially when it is small, and have comfort at hand.

Le système Zero Wall permet de ne jamais avoir à éloigner le canapé du mur. La solution idéale pour optimiser l'espace, particulièrement ceux de petites dimensions, pour un confort à portée de main.

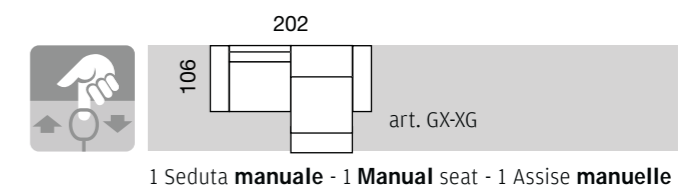
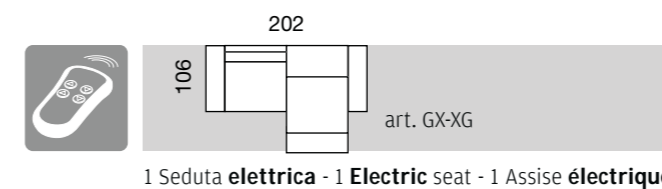

LA MACCHINA DEL RELAX

Con Eros le possibilità si moltiplicano, infatti, puoi abbinare la chaise longue ai meccanismi relax nelle tre versioni (fisso, manuale ed elettrico) e aggiungere anche il comodo poggiatesta, così il tuo divano si trasforma in una vera macchina del relax.

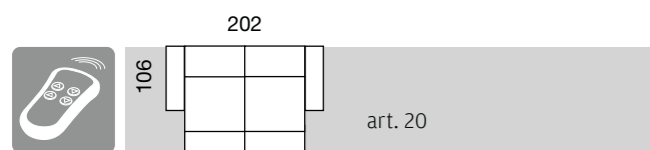

Seduta **elettrica** - **Electric seat** - Assise **électric**

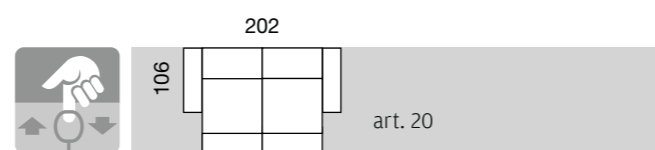

Seduta **manuale** - **Manual seat** - Assise **manuelle**

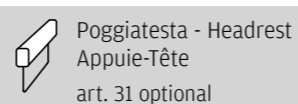

IMPORTANTE!

Qualora venga scelta una seduta fissa ed insieme una manuale, dovete sempre specificare la posizione della seduta con meccanismo (se è a destra o a sinistra).

PAY ATTENTION!

If a fixed seat is chosen together with a manual one, you must always specify the position of the seat with the mechanism (whether on the left, or on the right side).

ATTENTION !

Si vous choisissez une assise fixe en association à une autre manuelle, vous devez toujours spécifier l'emplacement de l'assise disposant du mécanisme (à droite ou à gauche).

EROS SI FA IN 3

Un divano, tre versioni: fisso, manuale ed elettrico. Inoltre, se preferisci, puoi avere una seduta fissa più una seduta manuale o elettrica.

EROS GOES ABOVE AND BEYOND

A sofa, three versions: fixed, manual, and electric. Upon request, you can also have a fixed seat together with a manual or electric one.

EROS SE PLIE EN 3

Un canapé, trois versions : fixe, manuel et électrique. De plus, si vous préférez, vous pouvez choisir d'associer un siège fixe et un siège à commande manuelle ou électrique.

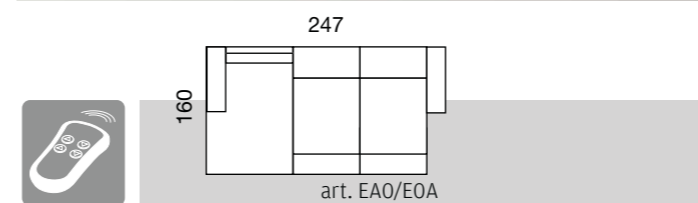

Seduta **elettrica** - **Electric seat** - Assise **électrique**

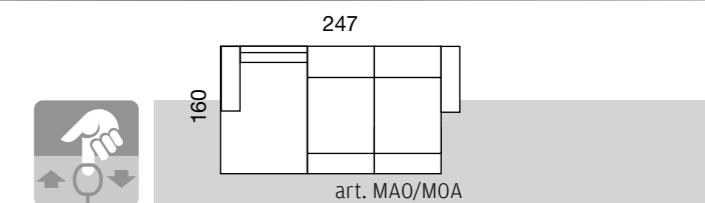

Seduta **manuale** - **Manual seat** - Assise **manuelle**

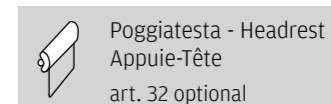

A MACHINE FOR RELAXATION

With Eros the possibilities multiply; in fact, you can combine the chaise longue with the relaxation mechanisms in three versions (fixed, manual, and electric), as well as add a comfortable headrest, so as to turn your sofa into a very relaxing machine.

LA MACHINE DE RELAXATION

Avec Eros, les possibilités se multiplient. En effet, vous pouvez associer la chaise longue aux mécanismes relax dans les trois versions (fixe, manuel ou électrique), tout en ajoutant également le confortable appuie-tête. Ainsi, votre canapé se transforme en une véritable machine de relaxation.

Struttura e molleggio

Realizzata con masselli portanti in legno di abete massiccio di vari spessori, parti di tamponamento in fibra grezza e/o compensato di legno. Fianchi in agglomerato di legno da 18 mm. Il tutto è in classe E1, pertanto a bassa emissione di formaldeide. Il tutto rivestito con vellutino 100% poliammide termocoppiato ad espanso e/o ovatta in fibra di poliestere 100%.

Molleggio realizzato con nastri elastici da 80 mm tesi meccanicamente, composti da fili di gomma ricoperti da filo di nylon avvolto a spirale.

Imbottitura e piedi

Cuscino seduta in doppia densità in poliestere espanso indeformabile D30 ricoperta con lastra in poliuretano espanso in D18, il tutto rivestito con teknoform 280 gr. termofissato a vellutino. Cuscino schienale in espanso indeformabile in D18 rivestito con resinato di poliestere 100gr. termofissato a vellutino. Cuscino bracciolo in espanso indeformabile in D18 rivestito con resinato di poliestere 100gr. termofissato a vellutino. Piedi in legno massello tipo wengè con profilo ABS finitura cromo.

Frame and springs

Made with bearing parts in solid fir wood, with various thicknesses, and reinforcement parts in rough fibre and/or poplar plywood. Sides made of 18 mm thick agglomerated wood chips, class E1 and then low formaldehyde emissions.

The whole is covered in 100% polyamide velveteen thermocoupled to foam and/or wadding in 100% polyester fibre.

Springs made with mechanically tightened 80 mm thick elastic bands, composed of rubber threads covered with nylon thread, coiled up in a spiral.

Padding and feet

Dual-density seat cushion in D30 polyester foam, covered with a D18 polyurethane foam plate, all covered with 280 g. TeknoForm. thermofixed to velveteen. Backrest with D18 foam cushion, coated with 100g. resin polyester. thermofixed to velveteen. Armrest with D18 foam cushion, coated with 100g. resin polyester. thermofixed to velveteen. Feet in solid wood, wengè type, with ABS chrome finish.

Structure et suspension

Réalisée avec des éléments porteurs en bois de sapin massif de plusieurs épaisseurs, parties de remplissage en fibres brutes et/ou contreplaqué. Panneaux latéraux en bois de 18 mm. Le tout appartenant à la classe E1 et donc à faible émission de formaldéhydes. L'ensemble est revêtu de velours 100% polyamide collé à chaud à la mousse et/ou ouate en fibres 100% polyester.

Suspension réalisée avec des bandes élastiques de 80 mm, tendues mécaniquement et composées de fils de caoutchouc recouverts de fil de nylon enroulé en spirale.

Rembouillage et pieds

Coussin d'assise double densité en polyester expansé indéformable D30 recouvert d'une couche de polyuréthane expansé en D18, le tout avec revêtement teknoform 280 g. fixé à chaud au velours. Coussin du dossier en mousse indéformable en D18 revêtu de résine de polyester de 100g. fixé à chaud au velours. Coussin de l'accoudoir en mousse indéformable en D18 revêtu de résine de polyester de 100 g. fixé à chaud au velours.

Piedi in bois massif de type wengè avec profilé ABS et finitions chromées.

POSIZIONE RELAX
RELAX POSITION
RELAX POSITION

 65 ↓ Art. F09 Versione fissa Fixed version Version fixe Art. M09 1 Seduta manuale 1 Manual seat 1 Assise manuelle Art. E09 1 Seduta elettrica 1 Electric seat 1 Assise électrique	 75 ↓ Art. F90 Versione fissa Fixed version Version fixe Art. M90 1 Seduta manuale 1 Manual seat 1 Assise manuelle Art. E90 1 Seduta elettrica 1 Electric seat 1 Assise électrique	 85 ↓ Art. F91 Versione fissa Fixed version Version fixe Art. M91 1 Seduta manuale 1 Manual seat 1 Assise manuelle Art. E91 1 Seduta elettrica 1 Electric seat 1 Assise électrique	 91 ↓ Art. F1D-F1S Versione fissa Fixed version Version fixe Art. MID-M1S 1 Seduta manuale 1 Manual seat 1 Assise manuelle Art. E1D-E1S 1 Seduta elettrica 1 Electric seat 1 Assise électrique	 101 ↓ Art. FIG-FG1 Versione fissa Fixed version Canapé fixe Art. MIG-MG1 1 Seduta manuale 1 Manual seat 1 Assise manuelle Art. E1G-EG1 1 Seduta elettrica 1 Electric seat 1 Assise électrique		
 117 ↓ Art. F01 Versione fissa Fixed version Version fixe Art. M01 1 Seduta manuale 1 Manual seat 1 Assise manuelle Art. E01 1 Seduta elettrica 1 Electric seat 1 Assise électrique	 182 ↓ Art. F02 Versione fissa Fixed version Version fixe Art. M04 1 Seduta manuale 1 Manual seat 1 Assise manuelle Art. E04 1 Seduta elettrica 1 Electric seat 1 Assise électrique Art. M40 1 Seduta manuale 1 Manual seat 1 Assise manuelle Art. E40 1 Seduta elettrica 1 Electric seat 1 Assise électrique Art. M02 2 Sedute manuali 2 Manual seat 2 Assises manuelles Art. E02 2 Sedute elettriche 2 Electric seat 2 Assises électriques	 202 ↓ Art. F20 Versione fissa Fixed version Version fixe Art. MGX 1 Seduta manuale 1 Manual seat 1 Assise manuelle Art. EGX 1 Seduta elettrica 1 Electric seat 1 Assise électrique Art. MXG 1 Seduta manuale 1 Manual seat 1 Assise manuelle Art. EXG 1 Seduta elettrica 1 Electric seat 1 Assise électrique Art. M20 2 Sedute manuali 2 Manual seat 2 Assises manuelles Art. E20 2 Sedute elettriche 2 Electric seat 2 Assises électriques	 111 ↓ Art. FMD-FMS Versione fissa Fixed version Version fixe Art. MMD-MMS 1 Seduta manuale 1 Manual seat 1 Assise manuelle Art. EMD-EMS 1 Seduta elettrica 1 Electric seat 1 Assise électrique	 156 ↓ Art. F2D-F2S Versione fissa Fixed version Version fixe Art. M4D-M4S 1 Seduta manuale 1 Manual seat 1 Assise manuelle Art. E4D-E4S 1 Seduta elettrica 1 Electric seat 1 Assise électrique Art. MX4-M4X 1 Seduta manuale 1 Manual seat 1 Assise manuelle Art. EX4-E4X 1 Seduta elettrica 1 Electric seat 1 Assise électrique Art. M2D-M2S 2 Sedute manuali 2 Manual seat 2 Assises manuelles Art. E2D-E2S 2 Sedute elettriche 2 Electric seat 2 Assises électriques	 176 ↓ Art. FGD-FGS Versione fissa Fixed version Version fixe Art. MXD-MXS 1 Seduta manuale 1 Manual seat 1 Assise manuelle Art. EXD-EXS 1 Seduta elettrica 1 Electric seat 1 Assise électrique Art. MX5-M5X 1 Seduta manuale 1 Manual seat 1 Assise manuelle Art. EX5-E5X 1 Seduta elettrica 1 Electric seat 1 Assise électrique Art. MGD-MGS 2 Sedute manuali 2 Manual seat 2 Assises manuelles Art. EGD-EGS 2 Sedute elettriche 2 Electric seat 2 Assises électriques	 196 ↓ Art. F3D-F3S Versione fissa Fixed version Version fixe Art. M6D-M6S 1 Seduta manuale 1 Manual seat 1 Assise manuelle Art. E6D-E6S 1 Seduta elettrica 1 Electric seat 1 Assise électrique Art. MX6-M6X 1 Seduta manuale 1 Manual seat 1 Assise manuelle Art. EX6-E6X 1 Seduta elettrica 1 Electric seat 1 Assise électrique Art. M3D-M3S 2 Sedute manuali 2 Manual seat 2 Assises manuelles Art. E3D-E3S 2 Sedute elettriche 2 Electric seat 2 Assises électriques
 222 ↓ Art. F03 Versione fissa Fixed version Version fixe Art. M06 1 Seduta manuale 1 Manual seat 1 Assise manuelle Art. E06 1 Seduta elettrica 1 Electric seat 1 Assise électrique Art. M60 1 Seduta manuale 1 Manual seat 1 Assise manuelle Art. E60 1 Seduta elettrica 1 Electric seat 1 Assise électrique Art. M03 2 Sedute manuali 2 Manual seat 2 Assises manuelles Art. E03 2 Sedute elettriche 2 Electric seat 2 Assises électriques	 247 ↓ Art. F07 Versione fissa Fixed version Version fixe Art. M51 1 Seduta manuale 1 Manual seat 1 Assise manuelle Art. E51 1 Seduta elettrica 1 Electric seat 1 Assise électrique Art. M52 1 Seduta manuale 1 Manual seat 1 Assise manuelle Art. E52 1 Seduta elettrica 1 Electric seat 1 Assise électrique Art. M53 1 Seduta manuale 1 Manual seat 1 Assise manuelle Art. E53 1 Seduta elettrica 1 Electric seat 1 Assise électrique	 Art. M54 1 Seduta manuale 1 Manual seat 1 Assise manuelle Art. E54 1 Seduta elettrica 1 Electric seat 1 Assise électrique Art. M55 1 Seduta manuale 1 Manual seat 1 Assise manuelle Art. E55 1 Seduta elettrica 1 Electric seat 1 Assise électrique Art. M56 2 Sedute manuali 2 Manual seat 2 Assises manuelles Art. E56 2 Sedute elettriche 2 Electric seat 2 Assises électriques Art. M07 3 Sedute manuali 3 Manual seat 3 Assises manuelles Art. E07 3 Sedute elettriche 3 Electric seat 3 Assises électriques	 160 Art. CD-CS Chaise Longue DX-SX RH-LH chaise l. Mériidienne D-G 160 Art. CG-GC Chaise Longue grande DX-SX RH-LH big chaise l. Mériidienne D-G 160 Art. CM-MC Chaise Longue maxi DX-SX RH-LH maxi chaise l. Mériidienne D-G 113 Art. AQ Angolo quadro Square corner Angle carré 26 Art. BR Bracciolo Armrest Manchette 31 Art. 31 Poggiatesta rettangolare Rectangular headrest Appuie-tête rectangulaire 52x15xH23 32 Art. 32 Poggiatesta con cilindro Headrest with roll Appuie-tête avec cylindre 52x15xH23 BT Art. BT Kit batteria tampone Battery kit Kit de batterie	 247 Composizione A Arrangement A Composition A 160 Composizione B Arrangement B Composition B 160 Composizione C Arrangement C Composition C		

GINGER style

La bellezza delle cose esiste nella mente di chi le osserva.
Beauty is in the eye of the beholder.
La beauté des choses existe dans l'esprit de qui les regarde.
- David Hume

Stai cercando un divano di design e nel contempo confortevole, perfetto per arredare la tua casa? Ginger è la soluzione ideale: è un divano componibile dotato di poggiatesta inclinabile in 15 posizioni per il massimo comfort. Il meccanismo è made in Japan sottoposto a severi test di resistenza.

Are you looking for a designer sofa, but comfortable at the same time, perfect for decorating your home? Ginger is the ideal solution: it is a modular sofa, whose headrest can be tilted in 15 different ways for maximum comfort. The mechanism is made in Japan and it is strictly tested for endurance.

Vous cherchez un canapé design et confortable à la fois, parfait pour meubler votre maison? Ginger est la solution idéale: un canapé modulaire avec appuie-tête inclinable réglable en 15 positions pour un confort maximum. Un mécanisme Made in Japan soumis à des tests de résistance rigoureux.

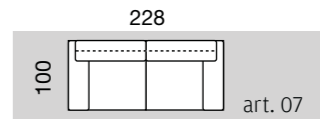
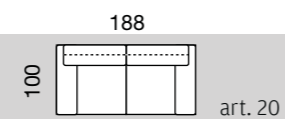

MOVIMENTO
POGGIATESTA
Brevettato

15 diverse inclinazioni

patented headrest movement - 15 different tilt positions
mouvement de l'appuie-tête breveté - 15 inclinaisons différentes

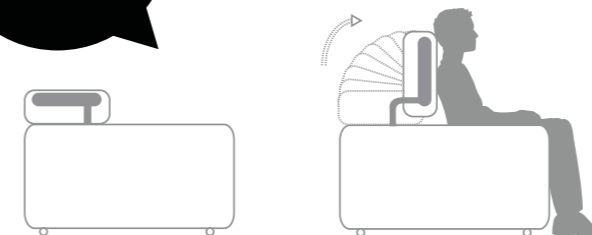



DIALOGA CON IL COMFORT

Ginger è un divano che, una volta seduto, ti comunica tutta la qualità delle cose ben costruite e la certezza di un relax assoluto, grazie al suo poggiatesta inclinabile in 15 diverse posizioni.

SPEAK WITH COMFORT

Ginger is the sofa that, once you sit on it, gives you the quality of well-constructed things and the certainty of absolute relaxation, thanks to its tilting headrest in 15 different positions.

DIALOGUEZ AVEC LE CONFORT

Ginger est un canapé qui, une fois assis, communique toutes les qualités des objets bien construits ainsi que la certitude d'un relax absolu grâce à son appuie-tête inclinable réglable en 15 positions.



Ogni parte di un insieme deve essere proporzionato all'insieme.

Each part of a whole must be proportionate to the whole.

Chaque partie d'un tout doit être en proportion avec l'ensemble. - Leonardo da Vinci



special price

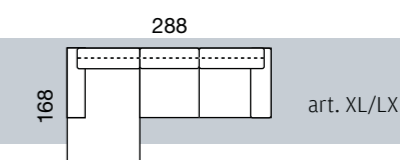
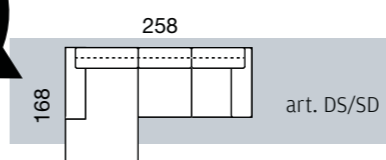

A caratterizzare la linea di Ginger i piedini in tubo d'acciaio cromato lucido. Un tocco glamour per un divano ideale ad arredare il centro stanza, che punta tutto su comfort ed estetica.

The Ginger line is characterized by the chromium steel tube feet. A touch of glamor for an ideal sofa to decorate the centre of the room, pointing everything on comfort and aesthetics.

Les pieds en tube d'acier chromé poli viennent caractériser la ligne de Ginger. Une touche de glamor pour ce canapé idéal pour décorer le centre de la pièce, concentrant l'ensemble sur le confort et l'esthétisme.

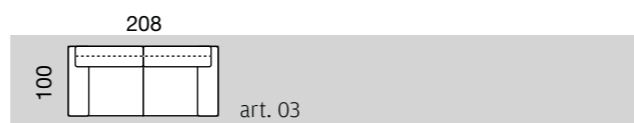

BIANCO MON AMOUR

Mai sottovalutare la potenza di questo super neutrale. Funziona con qualsiasi altro colore, in qualsiasi contesto, ovunque!

WHITE, MON AMOUR

Never underestimate the power of this super neutral colour. It can be matched with any other colour, in any context, anywhere!

BLANC MON AMOUR

Ne jamais sous-estimer la puissance du super neutre. Il fonctionne avec n'importe quelle autre couleur, peu importe le contexte, peu importe le lieu !

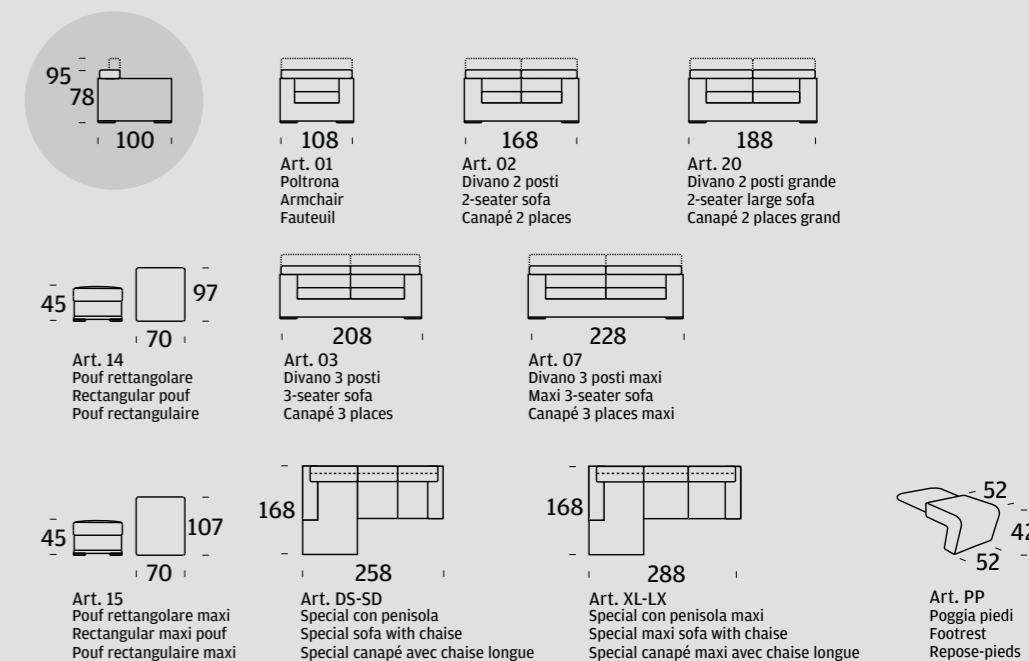

• LISTINO PREZZI / PRICE LIST / LISTE DES PRIX pag. 264

Struttura e molleggio

Realizzata con masselli in legno di abete massiccio di vari spessori, parti di tamponamento in fibra grezza e/o compensato di pino; fianchi in agglomerato di legno a bassa emissione di formaldeide (appartenente alla Classe E1). Poggiatesta dotato di cricchetto con innesto su bussola in acciaio con finitura cromo lucido. Possibilità di regolare l'inclinazione scegliendo tra 15 posizioni. MECCANISMO MADE IN JAPAN SOTTOPOSTO A SEVERI TEST DI RESISTENZA. Molleggio realizzato con nastri elastici composti da fili di gomma ricoperti da filo di nylon avvolto a spirale da 80mm, tesi meccanicamente.

Imbottitura e piedi

Cuscino seduta in espanso indeformabile con D30 fissato alla base tramite nastri di nylon con baionette in ABS (tipo zainetto), il tutto rivestito in resinato di poliestere 100%. Cuscino poggiatesta in espanso D16 indeformabile, rivestito in resinato di poliestere 100%. Poggiatesta con meccanismo, in espanso indeformabile in D28, il tutto rivestito in resinato di poliestere 100% accoppiato a vellutino 100% poliestere. Piede in tubo di acciaio cromato lucido H 4,4 cm.

Structure and springs

Made in solid fir of varying thicknesses, reinforcing parts in rough fibre and/or poplar plywood; sides in wood agglomerate with a low formaldehyde emission (Class E1). Headrest fitted with a ratchet with fitting on a steel bush and a polished chrome finish. Possibility of adjusting the inclination in 15 different positions. MECHANISM MADE IN JAPAN SUBJECTED TO STRICT RESISTANCE TESTS. Springs made of mechanically tightened 80 mm thick elastic bands, comprising rubber threads covered with nylon thread, coiled up in a spiral.

Upholstery and feet

Seat cushion in D30 non deformable foam secured to the base with nylon tapes with bayonet couplings in ABS (backpack type), covered with a 100% polyester resin. Backrest cushion in D16 non deformable foam, covered in 100% polyester resin. Headrest with mechanism, in D28 non deformable foam, all covered in 100% polyester resin coupled with 100% polyester velveteen. Foot in polished chromed steel tube, H 4.4 cm.

Structure et suspension

Réalisée avec des tasseaux en bois de sapin massif de diverses épaisseurs, éléments de remplissage en cellulose brute et/ou compensé de peuplier; panneaux latéraux en aggloméré de bois à basse émission de formaldéhydes (appartenant à la Classe E1). Appuie-tête équipé de cliquet greffé sur barillet tournant en acier avec finitions chrome brillant. Possibilité de régler l'inclinaison parmi les 15 positions proposées. MÉCANISME MADE IN JAPAN SOUMIS À DES TESTS DE RÉSISTANCE SÉVÈRES. Suspension réalisée avec des rubans élastiques composés de fils de caoutchouc recouverts d'un fil de nylon de 80 mm enroulé en spirale, avec tension appliquée mécaniquement.

Rembourrage et pieds

Coussin d'assise en expansé indéformable D30 fixé à la base par un système de rubans en nylon avec baïonnettes en ABS (type sac), le tout revêtu de résine 100 % polyester. Coussin pour le bas du dos en expansé D16 indéformable, revêtu de résine 100 % polyester. Appuie-tête à mécanisme, en expansé indéformable D28, le tout revêtu de résine 100 % polyester et de velours 100 % polyester. Pied en tube d'acier chromé brillant de 4,4 cm de hauteur.

FRED style

Una casa è una macchina per abitare.

A house is a machine for living.

Une maison est une machine à habiter. - Le Corbusier

Fai dominare la leggerezza nel tuo soggiorno grazie a Fred, il divano slanciato perfetto per arredare il centro stanza. Dotato di alti piedini in acciaio è una soluzione elegante, componibile in tante soluzioni diverse. Dotato di poggiatesta reclinabile in 15 diverse posizioni, questo sofà unisce la bellezza del design ad una comodità superiore.

Let lightness dominate your living room thanks to Fred, the slim sofa perfect to decorate the centre of the room. Equipped with high steel feet, it is an elegant solution, stackable in many different ways. Equipped with a reclining headrest in 15 different positions, this sofa combines beauty of design with superior comfort.

Faites dominer la légèreté dans votre salon grâce à Fred, le canapé à la ligne élancée, parfait pour décorer le centre de la pièce. Équipé de hauts pieds en acier, il représente une solution élégante, modulaire dans de nombreuses solutions. Équipé d'un appuie-tête inclinable à 15 positions, ce canapé allie la beauté du design à une commodité supérieure.



LE 15 POSIZIONI DEL RELAX

Con il suo poggiatesta inclinabile in 15 posizioni (meccanismo made in Japan sottoposto a severi test di resistenza) questo sofà unisce la bellezza del design ad una comodità superiore.

THE 15 POSITIONS OF RELAX

With its reclining headrest in 15 positions (a mechanism made in Japan, subjected to severe tests of resistance) this sofa combines beauty of design with superior comfort.

LA RELAXATION EN 15 POSITIONS

Avec son appuie-tête inclinable à 15 positions (mécanisme Made in Japan soumis à de rigoureux tests de résistance), ce canapé allie la beauté du design à une commodité supérieure.



special
price

288

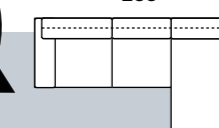

168

art. XL/LX



Bisogna essere ottimisti, perché qualcosa di buono può accadere in qualsiasi momento.
You should be optimistic, because something good can happen at any time.
Rester optimiste est important, car quelque chose de bien peut arriver à tout moment. - Zaha Hadid

special
price

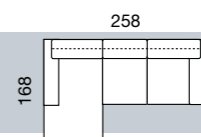

art. DS/SD

THE FASHION LOOK



L'occhio dell'uomo è in grado di distinguere in media 16 tonalità di grigio. Tutte perfette per arredare in modo elegante. Utilizzale per dare continuità e ampiezza all'ambiente.

The human eye is able to distinguish an average of 16 shades of grey. All perfect for decorating in an elegant way. Use them to provide continuity and amplitude to the environment.

L'œil humain est capable de distinguer une moyenne de 16 nuances de gris. Toutes parfaites pour une décoration au style élégant. Utilisez-les pour donner de la continuité et de l'amplitude à l'espace.

Le idee migliori sono proprietà di tutti.
The best ideas are common property.
Les meilleures idées appartiennent à tout le monde. - Seneca

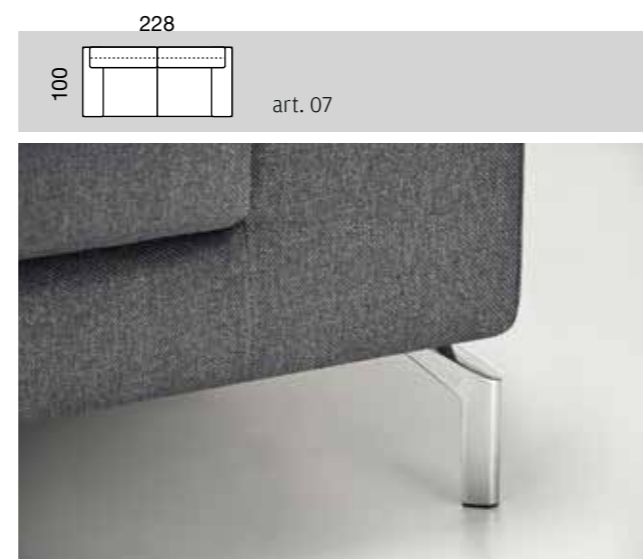

Piedino in finitura alluminio lucido.
Feet in polished aluminium finish.
Pieds finitions aluminium poli.



FUNZIONALE LEGGEREZZA

I particolari piedini in alluminio alleggeriscono lo spazio e regalano a Fred un design elegante e sofisticato.

FUNCTIONAL LIGHTNESS

The special aluminium feet lighten the space and give Fred a sleek and sophisticated design.

UNE LÉGÈRETÉ FONCTIONNELLE

Les pieds en aluminium tout à fait particuliers allègent l'espace et confèrent à Fred un design élégant et sophistiqué.

Art. 01 Poltrona Armchair Fauteuil 95 78 100	Art. 02 Divano 2 posti 2-seater sofa Canapé 2 places 108	Art. 03 Divano 3 posti 3-seater sofa Canapé 3 places 168	Art. 20 Divano 2 posti grande 2-seater large sofa Canapé 2 places grand 188
Art. 14 Pouf rettangolare Rectangular pouf Pouf rectangulaire 45 70 97	Art. 07 Divano 3 posti maxi Maxi 3-seater sofa Canapé 3 places maxi 208	Art. 07 Divano 3 posti maxi Maxi 3-seater sofa Canapé 3 places maxi 228	
Art. 15 Pouf rettangolare maxi Rectangular maxi pouf Pouf rectangulaire maxi 45 70 107	Art. DS-SD Special con penisola Special sofa with chaise Special canapé avec chaise longue 168 258	Art. XL-LX Special con penisola maxi Special maxi sofa with chaise Special canapé maxi avec chaise longue 168 288	Art. PP Poggia piedi Footrest Repose-pieds 52 42 52

• LISTINO PREZZI / PRICE LIST / LISTE DES PRIX pag. 266

Struttura e molleggio

Realizzata con masselli in legno di abete massiccio di vari spessori, parti di tamponamento in fibra grezza e/o compensato di pioppo; fianchi in agglomerato di legno a bassa emissione di formaldeide (appartenente alla Classe E1). Poggiatesta dotato di cricchetto con innesto su bussola in acciaio con finitura cromo lucido. Possibilità di regolare l'inclinazione scegliendo tra 15 posizioni. MECCANISMO MADE IN JAPAN SOTTOPOSTO A SEVERI TEST DI RESISTENZA. Molleggio realizzato con nastri elastici composti da fili di gomma ricoperti da filo di nylon avvolto a spirale da 80mm, tesi meccanicamente.

Imbottitura e piedi

Cuscino seduta in espanso indeformabile con D 30 fissato alla base tramite nastri di nylon con baionette in ABS (tipo zainetto), il tutto rivestito in resinato di poliestere 100%. Cuscino poggiatesta in espanso D16 indeformabile, rivestito in resinato di poliestere 100%. Poggiatesta con meccanismo, in espanso indeformabile in D 28, il tutto rivestito in resinato di poliestere 100% accoppiato a vellutino 100% poliestere. Piede in alluminio pressofuso lucidato meccanicamente con finitura cromo lucido H 15,5cm.

Structure and springs

Made in solid fir of varying thicknesses, reinforcing parts in rough fibre and/or poplar plywood; sides in wood agglomerate with a low formaldehyde emission (Class E1), backrest panel in multilayer poplar wood anchored to the base with galvanised bayonet couplings. Possibility of adjusting the inclination in 15 different positions. MECHANISM MADE IN JAPAN SUBJECT TO STRICT RESISTANCE TESTS. Springs made of mechanically tightened 80 mm thick elastic bands, comprising rubber threads covered with nylon thread, coiled up in a spiral.

Upholstery and feet

Seat cushion in D30 non deformable foam secured to the base with nylon tapes with bayonet couplings in ABS (backpack type), covered with a 100% polyester resin. Backrest cushion in D16 non deformable foam, covered in 100% polyester resin. Headrest with mechanism, in D28 non deformable foam, all covered in 100% polyester resin. Foot in mechanically polished die-cast aluminium with polished chrome finish, H 15.5cm.

Structure et suspension

Fabrique en bois de sapin massif de différentes épaisseurs, avec éléments de remplissage en fibres brutes et/ou contreplaqué de peuplier, panneaux latéraux en aggloméré de bois à faible émission de formaldéhyde (appartenant à la classe E1). Appuie-tête équipé de cliquet greffé sur barillet tournant en acier avec finitions chrome brillant. Possibilité de régler l'inclinaison parmi les 15 positions proposées. MÉCANISME MADE IN JAPAN SOUMIS À DES TESTS DE RÉSISTANCE SÉVÈRES. Suspension réalisée avec des rubans élastiques composés de fils de caoutchouc recouverts d'un fil de nylon de 80 mm enroulé en spirale, avec tension appliquée mécaniquement.

Rembourrage et pieds

Coussin d'assise en expansé indéformable D30 fixé à la base par un système de rubans en nylon avec baïonnettes en ABS (type sac), le tout revêtu de résine 100% polyester. Coussin pour le bas du dos en expansé D16 indéformable, revêtu de résine 100% polyester. Appuie-tête à mécanisme, en expansé indéformable D28, le tout revêtu de résine 100% polyester et de velours 100% polyester. Pied en aluminium moulé sous pression avec polissage mécanique finitions chromées brillantes de 15,5 cm de hauteur.



FRED & GINGER PRESENT

THE SOUND OF COMFORT

MUSIC SOFÀ



MUSIC sofà

Ginger e Fred possono essere dotati di un impianto di diffusione stereo incorporato. Nella Dock Station l'aggancio è predisposto per l'i-Phone4/5 (previsto adattatore Lightning) e l'i-Pod, o qualunque altro dispositivo che può essere collegato tramite Bluetooth o tramite la porta USB. Disponibile anche lettore sd-card oltre naturalmente all'uscita AUX. Il funzionamento dello stereo integrato nel divano è davvero semplice e intuitivo. Potrai ascoltare la tua musica preferita, le web radio, i podcast... e potrai anche ricaricare i tuoi dispositivi.

Ginger and Fred can be equipped with a built-in stereo speaker system. In the Dock Station, the socket fits the i-Phone 4/5 (Lightning adapter provided), and the i-Pod, or any other device that can be connected via Bluetooth or via the USB port.

Also available, an SD-card reader and, of course, an AUX output. The operation of the stereo integrated in the sofa is really simple and intuitive. You can listen to your favourite music, web radio stations, podcasts... and you can also charge your devices.

Ginger et Fred peuvent être équipés d'un système d'enceinte stéréo intégré. La station dispose d'une entrée pour i-Phone 4/5 (adaptateur Lightning fourni) et i-Pod, ou tout autre dispositif pouvant être connecté via Bluetooth ou port USB.

Un lecteur de carte SD est également disponible au même titre que la sortie AUX. Le fonctionnement de la chaîne stéréo intégrée dans le canapé est extrêmement simple et intuitif. Vous pourrez ainsi écouter votre musique préférée, la radio sur internet, les fichiers balado ... avec également la possibilité de recharger vos appareils.



RELAX MUSICALE

Hai mai pensato di ascoltare la tua musica preferita comodamente disteso sul tuo divano? Music sofà è la soluzione perfetta per te.

MUSIC RELAXATION

Have you ever thought of listening to your favourite music comfortably lying on your sofa? Music sofa is the perfect solution for you.

DÉTENTE MUSICALE

Avez-vous déjà pensé à écouter votre musique préférée confortablement allongé sur votre canapé? Music sofà est la solution parfaite pour vous.



Dock Station



GINGER style

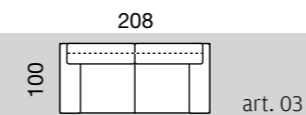

FRED style

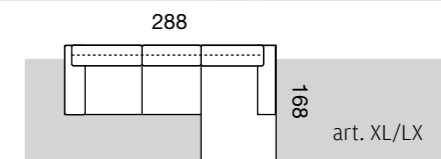

CASSE ACUSTICHE
Speakers
Haut-parleurs

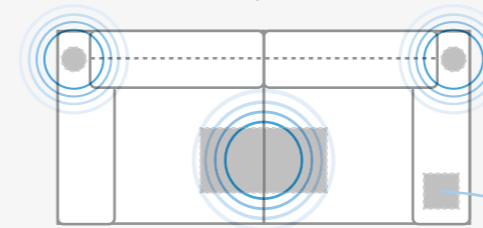

SUBWOOFER

CASSE ACUSTICHE
Speakers
Haut-parleurs

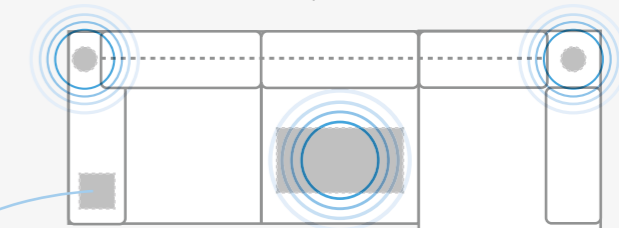

SUBWOOFER

Dock Station

I dispositivi collegati vengono anche ricaricati

The connected devices are also charged

Les appareils connectés sont également rechargés.



DEREK

style

La creatività è quel processo che dà vita a un nuovo prodotto.

Creativity is a process that results in novelty.

La créativité est le processus qui donne naissance à un nouveau produit.

James Taylor

IL TUO PICCOLO LUSSO QUOTIDIANO.

Accomodarsi, lasciarsi andare: nulla di meglio che un divano con lo schienale in misto piuma. Derek è un divano dalle sedute ampie e dalla linea elegante e moderna. Perfetto anche coordinato a pouf dalla forma quadrata.

YOUR DAILY LUXURY.

Sit yourself down, let yourself go: there's just nothing better than a sofa with a Dacron backrest. Derek is a sofa with ample seats and an elegant and modern line. Also perfect with the coordinated square pouf.

VOTRE ANGLE DE LUXE QUOTIDIEN.

Asseyez-vous, laissez-vous aller : rien de mieux qu'un canapé avec un dossier en plumes mélangées. Derek est un canapé proposant de vastes assises, dans une ligne élégante et moderne. Parfait également en coordination avec un pouf carré.



DOPPIA SCELTA BRACCIOLO

Versione A bracciolo 18 cm Derek nella versione più razionale con bracciolo sottile e minimale da 18 cm.

Versione B bracciolo 28 cm Derek nella versione più massiccia e comoda con il bracciolo più ampio da 28 cm.

DOUBLE CHOICE OF ARMREST

Version A 18 cm armrest Derek in a more rational version, with a slim and minimal 18 cm armrest.

Version B 28 cm armrest Derek in a more solid and comfortable version, with a slim and minimal 28 cm armrest.

ACCOUDOIR DOUBLE CHOIX

Version A accoudoir de 18 cm Derek dans sa version la plus rationnelle avec un accoudoir subtil et minimal de 18 cm.

Version B accoudoir de 28 cm Derek dans sa version massive et commode avec un accoudoir de 28 cm de large.

A
18 cm



B
28 cm



special
price

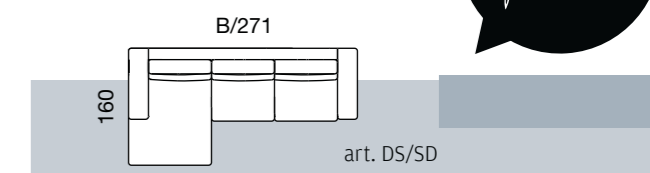

Poggiatesta - Headrest - Appuie-Tête
art. 31 optional



DETTAGLI IMPORTANTI

Il design di Derek si contraddistingue per l'elegante base-piede in finitura cromo lucido. Il comfort è assicurato dalle cuscinate in misto piuma degli schienali, capaci di regalare quel particolare tocco in più, fatto di morbidezza e adattabilità.

IMPORTANT DETAILS

The design of Derek stands out for its elegant-foot base in polished chrome finish. Comfort is assured by the Dacron back cushions, capable of giving that special touch, made of softness and adaptability.

DÉTAILS IMPORTANTS

Le design de Derek se distingue par son élégante base-pied avec finitions chrome poli. Le confort est assuré par les coussins en plumes mélangées du dossier, pour une touche toute particulière de douceur et d'adaptabilité.



A/212 B/232



A/99 B/119





Disponibile anche il poggiatesta nella stessa finitura del divano.

The headrest is also available in the same finish as the sofa.

Également disponible avec appuie-tête dans les mêmes finitions que le canapé.



Le anime più pure e più pensose sono quelle che amano i colori.
The purest and most thoughtful minds are those which love colour the most.
 Les âmes les plus pures et les plus penseuses sont celles qui aiment les couleurs.

I. Ruskin



Poggiatesta - Headrest - Appuie-Tête

art. 31 optional

A/194 B/214

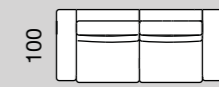

art. 06

Non ci deve essere un'arte staccata dalla vita: cose belle da guardare e cose brutte da usare.

Art should not be separated from life: beautiful things to look at and ugly things to use.

L'art ne doit pas se détacher de la vie : les belles choses à regarder et les laides à utiliser. - Bruno Munari



A
18 cm

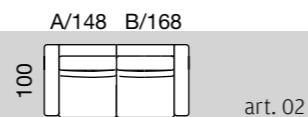

SCEGLI IL BRACCIOLO
CHE FA PER TE

CHOOSE THE ARMREST
FOR YOU

CHOISISSEZ
L'ACCOUDOIR QUI VOUS
CONVIENT LE MIEUX



B
28 cm

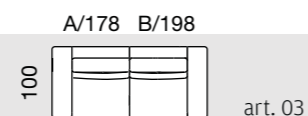

L'IMPORTANZA DEI TESSUTI ITALIANI

Protagonisti: i tessuti made in Italy

I tessuti sono i grandi protagonisti della collezione Style. Il centro stile dell'azienda ha lavorato alla realizzazione di nuove proposte che affondano le radici nel gusto e nella moda italiana.

THE IMPORTANCE OF ITALIAN FABRICS

Starring: fabrics made in Italy

Fabrics are the major players in the Style collection. The style centre of the company has worked on new proposals that have their roots in the Italian taste and fashion.

L'IMPORTANCE DES TISSUS ITALIENS

En vedette : les tissus Made in Italy

Les tissus ont le rôle principal dans la collection Style. Le centre stylistique de la société a travaillé sur de nouvelles propositions qui prennent leurs racines dans le goût et la mode italienne.



Bracciolo versione A da 18 cm
Version A 18 cm armrest
Accoudoir version A 18 cm

18

18

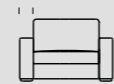

99

Art. 01
Poltrona
Armchair
Fauteuil

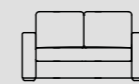

148

Art. 02
Divano 2 posti
2-seater sofa
Canapé 2 places

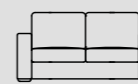

164

Art. 20
Divano 2 posti grande
2-seater large sofa
Canapé 2 places grand

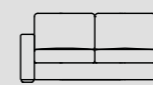

178

Art. 03
Divano 3 posti
3-seater sofa
Canapé 3 places

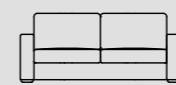

194

Art. 06
Divano 3 posti grande
3-seater large sofa
Canapé 3 places grand

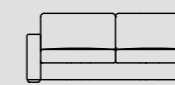

212

Art. 07
Divano 3 posti maxi
Maxi 3-seater sofa
Canapé 3 places maxi



Art. 30
Poggiatesta
Headrest
Appuie-tête
54x15xH15



Art. 31
Poggiatesta
Headrest
Appuie-tête
62x15xH15



Art. 33
Poggiatesta
Headrest
Appuie-tête
69x15xH15



Art. 36
Poggiatesta
Headrest
Appuie-tête
77x15xH15



Art. 37
Poggiatesta
Headrest
Appuie-tête
86x15xH15

28

Bracciolo versione B da 28 cm
Version B 28 cm armrest
Accoudoir version B 28 cm

28

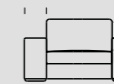

119

Art. 01
Poltrona
Armchair
Fauteuil

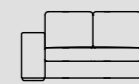

168

Art. 02
Divano 2 posti
2-seater sofa
Canapé 2 places

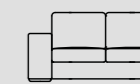

184

Art. 20
Divano 2 posti grande
2-seater large sofa
Canapé 2 places grand

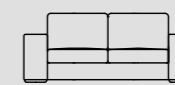

198

Art. 03
Divano 3 posti
3-seater sofa
Canapé 3 places

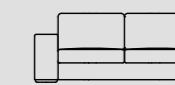

214

Art. 06
Divano 3 posti grande
3-seater large sofa
Canapé 3 places grand

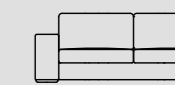

232

Art. 07
Divano 3 posti maxi
Maxi 3-seater sofa
Canapé 3 places maxi



Art. 30
Poggiatesta
Headrest
Appuie-tête
54x15xH15



Art. 31
Poggiatesta
Headrest
Appuie-tête
62x15xH15



Art. 33
Poggiatesta
Headrest
Appuie-tête
69x15xH15



Art. 36
Poggiatesta
Headrest
Appuie-tête
77x15xH15



Art. 37
Poggiatesta
Headrest
Appuie-tête
86x15xH15

160

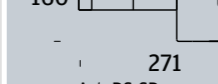

271

Art. DS-SD
Special con penisola
Special sofa with chaise
Special canapé avec chaise longue

160

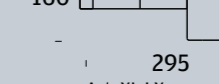

295

Art. XL-LX
Special con penisola maxi
Special maxi sofa with chaise
Special canapé maxi avec chaise longue

Special disponibile solo
con bracciolo da 28 cm
Special version available
only with 28 cm armrest
Version Special
uniquement disponible
avec accoudoir de 28 cm

• LISTINO PREZZI / PRICE LIST / LISTE DES PRIX pag. 269

Struttura e molleggio

Realizzata con masselli portanti in legno di abete massiccio di vari spessori, parti di tamponamento in fibra grezza e/o compensato. Fianchi in agglomerato di legno da 18 mm. Il tutto in classe E1, pertanto a bassa emissione di formaldeide, rivestito con vellutino 100% poliammide termoaccoppiato ad espanso e/o ovatta in fibra di poliestere 100%.
Molleggio realizzato con nastri elastici da 80 mm tesi meccanicamente, composti da fili di gomma ricoperti da filo di nylon avvolto a spirale.

Imbottitura e piedi

Cuscino seduta in espanso indeformabile D35 FR, in falda di poliestere da 300 g termolegata.
Cuscino schiena a 3 camere separate in pelle d'uovo, 65% poliestere, 35% cotone, riempite al 50% di piuma d'oca bianca e al 50% in fiocco di poliestere siliconato, con inserto in espanso indeformabile D165.
Piede in legno massello applicato al bracciolo con finitura cromo lucido.

Structure and springs

Made with bearing parts made of solid fir wood, with various thicknesses, reinforcement parts made of rough fibre and/or plywood. Sides made of agglomerated chips, with 18 mm thickness. All this in compliance with Class E1 and thus with low formaldehyde emission, covered in 100% polyamide velveteen, thermocoupled to foam and/or wadding in 100% polyester fibre.
Springing made with elastic bands composed of tightened rubber threads covered with nylon thread, coiled up in a spiral, with 80 mm thickness.

Upholstery and feet

Seating pillow made of D35 FR indeformable foam, in thermobond polyester lap with 300 gr weight. Back pillow with 3 separated chambers in egg leather, 65% polyester, 35% cotton, 50% filled with white goose feather and 50% with siliconized polyester flakes, with an insert made of D165 indeformable foam.
Foot made of heartwood, applied to the arm, with bright chrome finishes.

Structure et suspension

Réalisée avec des duramens portants en bois de sapin massif de plusieurs épaisseurs, parties de fileurs en fibre brute et/ou contreplaqué. Côtés en bois aggloméré de 18 mm, le tout de classe E1, donc à basse émission de formaldéhyde, revêtu de velours 100% polyamide associé thermiquement à l'expansé et/ou ouate en fibre de polyester 100%.
Suspension réalisée avec des bandes élastiques composées de fils de caoutchouc recouverts de fil de nylon enroulé en spirale, tendus, de 80 mm.

Rembourrage et pieds

Coussin de l'assise en expansé indeformable D35 FR, en voile de polyester de 300 g associé thermiquement.
Coussin pour le dos à 3 chambres séparées, en mousseline, 65% polyester, 35% coton, remplies à 50% de plume d'oie blanche et à 50% en flocon de polyester à la silicone, avec insert en expansé indeformable D165.
Pied en bois massif appliqué à l'accoudoir avec finition chrome brillant.

ARON

style

Creare è dare una forma al proprio destino.

To create is to shape your own fate.

Créer, c'est donner une forme à son destin. - Albert Camus

PROPORZIONI ARROTONDATE.

Chi ha detto che design significhi per forza forme squadrate e tratti rigorosi? Style crede nelle proporzioni arrotondate, nelle linee morbide e nei dettagli eleganti che offrono un comfort esclusivo. Ecco perché abbiamo progettato Aron, per accogliere ogni tuo istante di relax.

ROUNDED PROPORTIONS.

Who said design means square shapes and rigorous traits at all costs? Style believes in rounded proportions, soft lines, and elegant details that offer utmost comfort. That's why we have designed Aron, to accommodate every relaxation needs.

PROPORTIONS ARRONDIES.

Qui a dit que le design se traduit obligatoirement par des formes carrées et des lignes rigoureuses? Style croit dans les proportions arrondies, des lignes douces et les détails élégants pour un confort exclusif. C'est pourquoi nous avons conçu Aron, pour répondre à tous vos moments de détente.

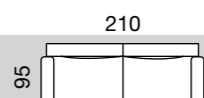

art. 03



SPAZIO AI DETTAGLI

A volte basta un cuscino, un tappeto diverso, un quadro per ravvivare l'arredo del vostro living. La chiave è il contrasto. Mixa colori neutri con piccoli tocchi più accesi. Il tuo soggiorno si arricchirà di personalità.

SPACE FOR DETAILS
Sometimes all you need is a pillow, a different rug, a picture, to liven up the decor of your living room. Contrast is the key. Mix neutral colours with few stronger touches. Your living-room will be enriched by your personality.

PLACE AUX DÉTAILS
Parfois, il suffit d'un simple coussin, d'un autre tapis, un cadre pour égayer le décor de votre salon. La clé est dans le contraste. Mélangez les tons neutres avec une touche de couleurs vives. Votre séjour aura une plus grande personnalité.





LA FORMA CHE SOGNI

A mezzaluna o più rettangolare, grazie ai pouf sagomati accostati al divano potrai aggiungere un posto in più o allungare le gambe in posizione di relax.

THE SHAPE OF YOUR DREAMS

Whether they are semi-circular or more rectangular, the shaped poufs placed beside the sofa can make an extra seat or allow more room to stretch your legs in a relaxed position.

LA FORME DONT VOUS RÊVEZ

En demi-lune ou plus rectangulaire, grâce aux formes découpées des poufs placés à côté du canapé, vous pourrez ajouter une place supplémentaire ou allonger vos jambes pour une position détendue.



Il bello è lo splendore del vero.
Beauty is the splendour of truth.
 La beauté est la splendeur du vrai. - Platone

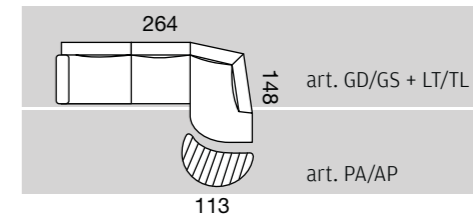

LOMBARE
con cucitura
LUMBAR
with seam
LOMBAIRE
avec coutures



TANTE
SOFFICI
CURVE

Una volta che ti sarai accomodato su questo divano, scoprirai tutta la sua morbidezza: soffici braccioli, schienale alto dalla forma arrotondata avvolgente come un guscio. Per un perfetto relax.

MANY SOFT CURVES

Once you sit on this couch, you'll discover all its softness: soft armrests, high backrest with a rounded shape, enveloping as a shell. For perfect relaxation.

DES COURBES DOUCES EN QUANTITÉ

Une fois installé dans votre canapé, vous en découvrirez toute la douceur : celle des accoudoirs, le haut dossier de forme arrondie et enveloppante comme une coquille. Pour une détente parfaite.

CUSCINO LOMBARE

LISCIO O CON CUCITURE

Aron è dotato di fascia cuscino lombare, disponibile sia nella versione con cuciture verticali sia nella versione liscia, in grado di sostenere la parte lombare e i dischi intervertebrali, assicurando così una postura rilassata e corretta.

LUMBAR CUSHION PLAIN OR WITH SEAMS

Aron has a lumbar band cushion, available with vertical seams or plain, capable of supporting the lumbar spine and intervertebral discs, thus ensuring a relaxed and correct posture.

COUSSIN LOMBAIRE UNI OU AVEC COUTURES

Aron dispose d'une bande de coussin lombaire, également disponible en version avec coutures verticales ou unie, pour maintenir les lombaires et les disques intervertébraux, assurant ainsi une posture détendue et correcte.



LOMBARE
liscia
LUMBAR
smooth
LOMBAIRE
uni

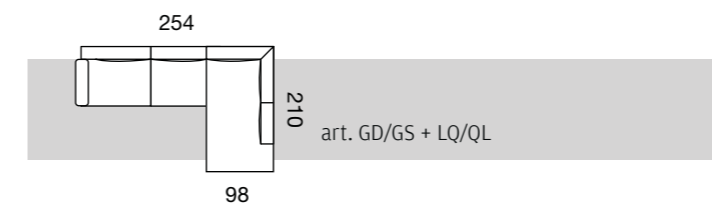
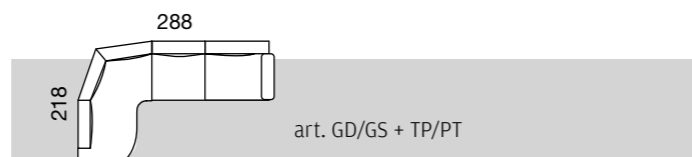

La perfezione si ottiene non quando non c'è nient'altro da aggiungere, bensì quando non c'è più niente da togliere.

Perfection is not achieved when there is nothing left to add, but when there is nothing left to take away.

La perfection est atteinte, non pas lorsqu'il n'y a plus rien à ajouter, mais lorsqu'il n'y a plus rien à retirer. - Antoine de Saint-Exupéry

Ecco le domande che dovete fare prima di acquistare un divano. Quale stile si addice alla tua casa: classico o moderno? Quanto spazio avete a disposizione? Che uso farete del divano?

Here are the questions you need ask yourself before buying a sofa. Which style suits your home: classic or modern? How much space do you have available? What use will you make of the sofa?

Voici les questions que vous devez vous poser avant d'acheter un canapé. Quel style convient à votre maison : classique ou moderne ? De combien d'espace disposez-vous ? Quel usage ferez-vous de votre canapé ?

Lo schienale alto di Aron è studiato per seguire le forme della tua schiena e garantire una posizione di relax ottimale.

The high backrest of Aron is designed to follow the shape of your back and ensure optimum relaxation.

Le haut dossier du modèle Aron est conçu pour épouser les formes de votre dos et assurer une position de détente optimale.



93 95

Art. 01 Poltrona Armchair Fauteuil 115

Art. 02 Divano 2 posti 2-seater sofa Canapé 2 places 153

Art. 20 Divano 2 posti maxi 2-seater maxi sofa Canapé 2 places maxi 174

Art. 03 Divano 3 posti 3-seater sofa Canapé 3 places 210

Art. 07 Divano 3 posti maxi 3-seater maxi sofa Canapé 3 places maxi 225

Art. 09 Elemento centrale Central element Chauffeuse 58

69

Art. 90 Elemento centrale maxi Maxi central element Chauffeuse maxi

76

Art. 1D-1S Laterale 1 posto DX-SX RH-LH 1-seater side el. Canapé bâtarde 1 place D-G

87

Art. MD-MS Laterale 1 posto maxi DX-SX RH-LH maxi 1-seater side el. Canapé bâtarde 1 place maxi D-G

134

Art. 2D-2S Laterale 2 posti DX-SX RH-LH 2-seater side el. Canapé bâtarde 2 places D-G

156

Art. GD-GS Laterale 2 posti grande DX-SX RH-LH 2-seater large side el. Canapé bâtarde 2 places grand D-G

192

Art. 3D-3S Laterale 3 posti DX-SX RH-LH 3-seater side el. Canapé bâtarde 3 places D-G

98

Art. LQ-QL Laterale angolo quadro DX-SX RH-LH square corner side el. Canapé bâtarde angle carré D-G

132

Art. TP-PT Terminale angolo tondo DX-SX RH-LH round corner end element Terminal angle rond D-G

76

Art. CD-CS Chaise longue reversibile DX-SX RH-LH reversible chaise l. Méridienne réversible D-G

87

Art. CM-MC Chaise longue reversibile maxi DX-SX RH-LH reversible maxi chaise l. Méridienne réversible maxi D-G

108

Art. LT-TL Laterale angolo aperto DX-SX RH-LH open corner side el. Canapé bâtarde angle ouvert D-G

113

60

Art. PA-AP Pouf anteriore DX-SX RH-LH front pouf Pouf avant D-G

108

108

Art. AT Angolo Tondo Round corner Angle rond

98

98

Art. AQ Angolo quadro Square corner Angle carré

75

50

Art. 14 Pouf anteriore rettangolare Rectangular front pouf Pouf avant rectangulaire

44

67

57

Art. 13 Pouf rettangolare Rectangular pouf Pouf rectangulaire

• LISTINO PREZZI / PRICE LIST / LISTE DES PRIX pag. 273

NB: se non specificato diversamente il lombare è realizzato con cucitura.

NOTE: unless otherwise specified, the lumbar has seams.

NB : sauf indication contraire, le coussin lombaire est réalisé dans sa version avec coutures.

Struttura e molleggio

Struttura realizzata con masselli portanti in legno di pioppo o abete di vari spessori. Parti di tamponamento in fibra grezza o compensato di pioppo da 2,5 mm. Fianchi in agglomerato di legno da 18 mm. Il tutto rivestito in vellutino 100% poliammide termoaccoppiato ad espanso e/o ovatta di fibra di poliestere resinata. Molleggio realizzato mediante nastri elastici da 80 mm tesi meccanicamente, composti da fili di gomma ricoperti da filo di nylon avvolto a spirale.

Imbottitura e piedi

Cuscino di seduta in espanso indeformabile D30, rivestito con ovatta di fibra di poliestere da 200 g resinata. Cuscino schiena in espanso indeformabile D18, rivestito con ovatta di fibra di poliestere da 100 g resinata. Tamponi e sagomati vari a completamento in D25 e D21. Poggiareni in fiocco di poliestere cava siliconata 100% vergine, contenuta da rivestimento in T.N.T. 50 g. Cuscino bracciolo in espanso D18 rivestito da ovatta di fibra poliestere da 300 g termolegata. I piedini sono in ABS color legno o alluminio.

Structure and springs

Structure made with bearing parts in poplar or fir wood in various thicknesses. Reinforcing parts made of rough fibre or 2.5 mm thick poplar plywood. Sides in 18 mm agglomerated wood chips. The whole covered in 100% polyamide velvetene thermocoupled to foam and/or resinated polyester fibre wadding. Springs made of mechanically tightened 80 mm thick elastic bands, comprising rubber threads covered with nylon thread coiled up in a spiral.

Upholstery and feet

Seat cushion in D30 non deformable foam, covered with 200 g resinated polyester fibre wadding. Backrest cushion in D18 non deformable foam, covered with 100 g resinated polyester fibre wadding. Various shaped elements and reinforcements to complete in D25 and D21. Backrest in 100% virgin silicone hollow polyester flakes, contained by a 50 g T.N.T. covering 50 g. Armrest cushion in D18 foam covered with 300 g thermobonded polyester fibre wadding. Feet are made of wood or aluminium colored ABS.

Structure et suspension

Structure réalisée en panneaux massifs de peuplier ou de sapin de différentes épaisseurs. Éléments de remplissage en fibre brute ou en contreplaqué de peuplier de 2,5 mm. Côtés en bois aggloméré de 10 mm. La tout revêtu de velours 100% polyamide thermiquement associé à expansé et/ou à ouate de fibre polyester résine. Suspension réalisée à l'aide de sangles élastiques de 80 mm tendues mécaniquement, composée de fils de caoutchouc recouverts de fil de nylon enroulé en spirale.

Rembourrage et pieds

Coussin d'assise en expansé indeformable de D30, revêtu d'ouate de fibre polyester résine de 200 g. Coussin d'assise en expansé indeformable de D18, revêtu d'ouate de fibre polyester résine de 100 g. Garnissage et différents modale en complément en D25 et D21. Coussin lombaire en flocon de polyester creux siliconé 100% vierge, enveloppé d'un revêtement en T.N.T. 50 g. Coussin accoudoir en expansé de D18 revêtu d'ouate de fibre polyester de 300 g associée thermiquement. Les pieds sont en bois ou en aluminium coloré ABS.

LEON style



Un uomo percorre il mondo intero in cerca di ciò che gli serve e torna a casa per trovarlo.

A man travels the world over in search of what he needs and returns home to find it.

Un homme parcourt le monde entier à la recherche de ce dont il a besoin et rentre chez lui pour le trouver.. - George Moore

LINEAR DESIGN

Forme ampie e distese, design pulito e lineare. Leon è un divano componibile moderno. La versione dotata di chaise longue è la scelta ideale per esaltare la comodità e sfruttare al meglio lo spazio.

Large and stretched shapes, clean and linear design. Leon is a modern modular sofa. The version with the chaise longue is the ideal choice to enhance the comfort and make the most of the space.

Des formes amples et étendues, un design épuré et linéaire. Leon est un canapé modulaire moderne. La version avec chaise longue est le choix idéal pour améliorer le confort et tirer le meilleur parti de l'espace.



A/274

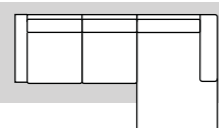

159

art. XG/GX + CD/CS



A/197



106

art. 2E

Un'intuizione è la creatività che cerca di dirti qualcosa.

A hunch is creativity trying to tell you something.

Une intuition est la créativité qui tente de vous dire quelque chose. - Frank Capra



COLOR IN MOTION

3 CONSIGLI COLOR STYLE

1) In spazi piccoli uno stesso colore utilizzato in differenti tonalità può aiutare a dare continuità e ampiezza all'ambiente. 2) Il soffitto molto alto di un ambiente, se dipinto di scuro, aiuta ad avvicinarlo visivamente al resto della stanza 3) Le tinte tenui danno sensazioni di freschezza.

3 COLOUR STYLE TIPS

1) In a small space, the same colour used in different shades can help provide continuity and amplitude to the environment. 2) The very high ceiling of a room, if painted dark, helps to visually bring it closer to the rest of the room 3) Soft colours give a feeling of freshness.

3 CONSEILS COLOR STYLE

1) Dans les petits espaces, une même couleur utilisée dans différentes nuances peut aider à maintenir la continuité et l'amplitude de l'espace. 2) Le plafond très élevé d'une pièce, s'il est peint de couleur sombre, contribue à le rapprocher visuellement du reste de la pièce 3) Les couleurs douces donnent une sensation de fraîcheur.



RELAX BILANCIATO AL PESO

Allungare le gambe e godersi intensi attimi di relax grazie a Leon, il divano con la seduta allungabile a scorrimento. L'esclusivo meccanismo brevettato da Felis consente di regolare alla perfezione lo scorrimento del meccanismo al peso di chi utilizzerà il divano.



RELAX BALANCED TO WEIGHT

Stretch your legs and enjoy intense moments of relaxation thanks to Leon, the sofa with the pull-out sliding seat. This exclusive mechanism, patented by Felis, allows to adjust the sliding mechanism perfectly to the weight of those who sit on the sofa.



L'ÉQUILIBRE RELAX/POIDS

Allonger les jambes et profiter de moments intenses de relaxation grâce à Leon, avec son assise extensible à coulissement. L'exclusif mécanisme breveté par Felis permet d'ajuster à la perfection le coulissement du mécanisme au poids de qui utilise le canapé.

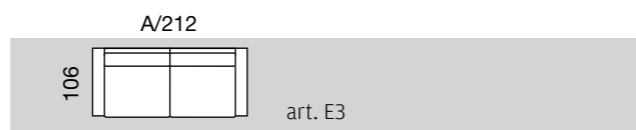

COMFORT GARANTITO

Forme ampie e distese, design pulito e lineare, Leon nella versione B è caratterizzato da bassi braccioli dotati di comodo cuscino per il massimo comfort.

GUARANTEED COMFORT

Large and stretched shapes, clean and linear design, Leon in the B version is characterized by low armrests with comfortable cushion for maximum comfort.

CONFORT ASSURÉ

Des formes amples et étendues, un design épuré et linéaire, Leon dans sa version B est caractérisé par des accoudoirs bas dotés d'un confortable coussin pour un plaisir maximum.

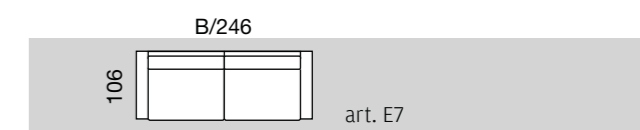

SCEGLI IL TUO BRACCIOLO

Ami i divani con braccioli bassi e morbidi oppure li preferisci con braccioli larghi e quadrati? Con Leon scegli tu il bracciolo che preferisci. Leon divano componibile dalle forme lineari con possibilità di scegliere tra due tipologie di bracciolo (basso e morbido o largo e quadrato), la seduta è allungabile con un meccanismo brevettato da Felis.

CHOOSE YOUR ARMREST

Do you love sofas with low and soft armrests, or do you prefer them with wide and square armrests? With Leon you can choose the armrest you prefer. Leon is a sectional sofa with linear shapes and the possibility to choose between two types of armrests (low and soft, or wide and square), the seat is stretchable by a mechanism patented by Felis.

CHOISISSEZ VOTRE ACCOUDOIR

Vous aimez les canapés aux accoudoirs bas et moelleux, ou préférez-vous avec accoudoirs larges et carrés? Avec Leon, choisissez l'accoudoir que vous préférez. Leon est un canapé modulaire aux formes linéaires offrant la possibilité de choisir entre deux types d'accoudoirs (bas et moelleux ou large et carré), l'assise peut être allongée grâce à un mécanisme breveté par Felis.

A
23 cm



B
25 cm



A/182

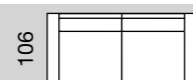

art. E2

PROFONDITÀ DIVANO APERTO CM. 141 - OPEN SOFA DEPTH CM. 141 - PROFONDEUR CANAPÉ OUVERT CM. 141

BRACCIOLO "A" DIRITTO 23 cm - ARMREST "A" STRAIGHT 23 cm - ACCOUDOIR "A" DROIT 23 cm

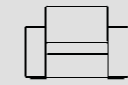

104
Art. E1/01
Poltrona
Armchair sofa
Fauteuil

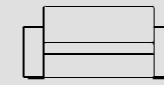

162
Art. E6/06
Divano 2 posti mini
Small 2-seater sofa
Canapé 2 places mini

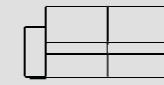

182
Art. E2/02
Divano 2 posti
2-seater sofa
Canapé 2 places

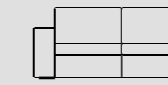

197
Art. 2E/20
Divano 2 posti grande
2-seater large sofa
Canapé 2 places grand

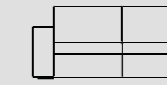

212
Art. E3/03
Divano 3 posti
3-seater sofa
Canapé 3 places



83
106
141

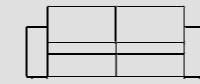

228
Art. E5/05
Divano 3 posti big
Big 3-seater sofa
Canapé 3 places big

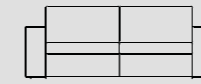

242
Art. E7/07
Divano 3 posti maxi
Maxi 3-seater sofa
Canapé 3 places maxi

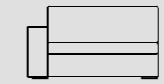

139
Art. X6-6X/6D-6S
Laterale 2 posti mini DX-SX
RH-LH 2-seater small side el.
Canapé bâtarde 2 places mini D-G

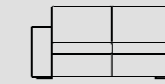

159
Art. X2-2X/2D-2S
Laterale 2 posti DX-SX
RH-LH 2-seater side el.
Canapé bâtarde 2 places D-G

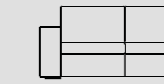

175
Art. XG-GX/GD-GS
Laterale 2 posti grande DX-SX
RH-LH 2-seater big side el.
Canapé bâtarde 2 places grand D-G

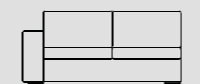

189
Art. X3-3X/3D-3S
Laterale 3 posti DX-SX
RH-LH 3-seater side el.
Canapé bâtarde 3 places D-G

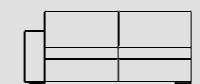

205
Art. X5-5X/5D-5S
Laterale 3 posti grande DX-SX
RH-LH 3-seater big side el.
Canapé bâtarde 3 places grand D-G

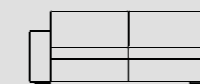

219
Art. X7-7X/7D-7S
Laterale 3 posti maxi DX-SX
RH-LH 3-seater maxi side el.
Canapé bâtarde 3 places maxi D-G

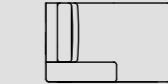

159
Art. CD-CS
Chaise longue DX-SX
RH/LH chaise l.
Mériidienne D-G



159
Art. CG-GC
Chaise longue grande DX-SX
RH/LH bigchaise l.
Mériidienne big D-G



159
Art. CM-MC
Chaise longue Maxi DX-SX
RH/LH maxi chaise l.
Mériidienne maxi D-G

BRACCIOLO "B" INCLINATO 25 cm - ARMREST "B" OBLIQUE 25 cm - ACCOUDOIR "B" INCLINÉ 25 cm

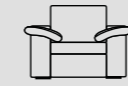

108
Art. E1/01
Poltrona
Armchair sofa
Fauteuil

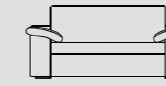

166
Art. E6/06
Divano 2 posti mini
Small 2-seater sofa
Canapé 2 places mini

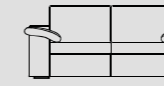

186
Art. E2/02
Divano 2 posti
2-seater sofa
Canapé 2 places

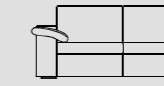

201
Art. 2E/20
Divano 2 posti grande
2-seater large sofa
Canapé 2 places grand

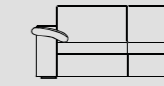

216
Art. E3/03
Divano 3 posti
3-seater sofa
Canapé 3 places

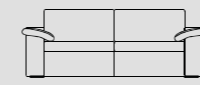

232
Art. E5/05
Divano 3 posti big
Big 3-seater sofa
Canapé 3 places big

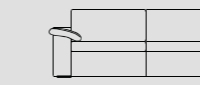

246
Art. E7/07
Divano 3 posti maxi
Maxi 3-seater sofa
Canapé 3 places maxi

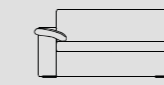

141
Art. X6-6X/6D-6S
Laterale 2 posti mini DX-SX
RH-LH 2-seater small side el.
Canapé bâtarde 2 places mini D-G

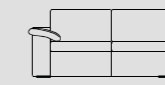

161
Art. X2-2X/2D-2S
Laterale 2 posti DX-SX
RH-LH 2-seater side el.
Canapé bâtarde 2 places D-G

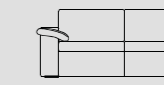

177
Art. XG-GX/GD-GS
Laterale 2 posti grande DX-SX
RH-LH 2-seater big side el.
Canapé bâtarde 2 places grand D-G

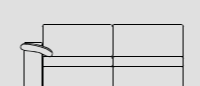

191
Art. X3-3X/3D-3S
Laterale 3 posti DX-SX
RH-LH 3-seater side el.
Canapé bâtarde 3 places D-G

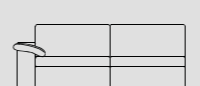

207
Art. X5-5X/5D-5S
Laterale 3 posti grande DX-SX
RH-LH 3-seater big side el.
Canapé bâtarde 3 places grand D-G

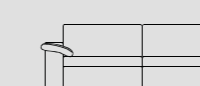

221
Art. X7-7X/7D-7S
Laterale 3 posti maxi DX-SX
RH-LH 3-seater maxi side el.
Canapé bâtarde 3 places maxi D-G

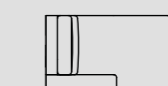

159
Art. CD-CS
Chaise longue DX-SX
RH/LH tchaise l.
Mériidienne D-G

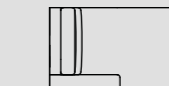

159
Art. CG-GC
Chaise longue grande DX-SX
RH/LH bigchaise l.
Mériidienne big D-G

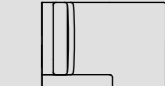

159
Art. CM-MC
Chaise longue Maxi DX-SX
RH/LH maxi chaise l.
Mériidienne maxi D-G

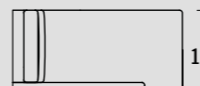

195
Art. TD-TS
Terminale DX-SX
RH-LH end element
Terminal D-G



56
38
Art. 17
Cuscino schiena terminale
End back cushion
Cousin dossier terminal
56x22xH38



40
98
73
Art. 13
Pouf rettangolare maxi
Rectangular maxi pouf
Pouf rectangulaire maxi

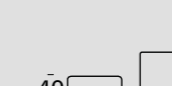

40
84
69
Art. 14
Pouf rettangolare
Rectangular pouf
Pouf rectangulaire



40
103
103
Art. 15
Pouf quadrato
Square pouf
Pouf carré

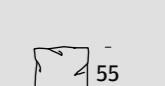

55
55
Art. 19
Cuscino saponetta grande "Leon"
"Leon" shaped large cushion
Cousin en forme de savon grand "Leon"

• LISTINO PREZZI / PRICE LIST / LISTE DES PRIX pag. 277

Struttura e molleggio

Telaio in legno con parti di abete essiccato di vari spessori e agglomerato di legno da 18 mm. Rivestito da magliana di poliester. Il tutto realizzato con particelle di legno a bassa emissione di formaldeide (classe E1), ai sensi delle norme UNI EN 312-1 e UNI EN 120. Molleggio realizzato mediante nastri elastici da 80 mm tesi meccanicamente, composti da fili di gomma ricoperti da nylon avvolto a spirale.

Seduta estraibile

Telaio in ferro del tipo FE 360 con ruote. Verniciatura realizzata con resina epossipoliester, non infiammabile. Ruote di scorrimento per seduta h 70 mm in acciaio zincato con piastra ad H, rivestite in polipropilene/gomma termoplastica antitraccia.

Imbottitura e piedi

Cuscino seduta in poliuretano espanso in D30SPP indeformabile. Cuscini schienale in D25M indeformabile, il tutto rivestito in falda termolegata da 300 g. Versione (B) cuscino bracciolo in D25 indeformabile rivestito in falda termolegata da 300 g. Piedino in ABS nero da h 40 mm.

Structure and springs

Frame made of wood with parts in dried fir wood, with various thicknesses, and agglomerated chocks with 18 mm thickness. Covered in polyester jersey. The whole is made of wood particles with low formaldehyde emission (Class E1), in compliance with the UNI EN 312-1 and UNI EN 120 norms. Spring made of mechanically tightened elastic bands with 80mm thickness, composed of rubber threads covered with nylon, coiled up in a spiral.

Pull-out seating

Iron frame of the FE 360 type, with wheels. Coating made with epoxy-polyester resin, unflammable. Sliding wheels for seating, with 70 mm height, in zinc-plated steel with H shaped plate, covered in anti-mark polypropylene / hot melt rubber.

Upholstery and feet

Seating pillow in polyurethane foam, with D30SPP, indeformable. Backrest cushions in D25, indeformable. The whole is covered in 300 g thermobond lap. Version (B) of the armrest cushion, D25 indeformable, covered in 300 g thermobond lap. Feet in black ABS with h 40 mm.

Structure et suspension

Cadre en bois avec parties en sapin séché d'épaisseurs différentes et bois aggloméré de 18 mm. Revêtu de jersey de polyester. Le tout réalisé avec des particules de bois à basse émission de formaldéhyde (classe E1), conformément aux normes UNI EN 312-1 et UNI EN 120. Suspension réalisée avec des bandes élastiques de 80 mm, tendues mécaniquement, composées de fils de caoutchouc recouverts de nylon enroulé en spirale.

Assise extractible

Cadre en fer du type FE 360 avec roues. Peinture réalisée avec une résine époxy polyester, non inflammable. Roues de coulissement pour l'assise h 70 mm en acier zingué avec plaque en H, revêtues en polypropylène/caoutchouc thermoplastique anti-taches.

Rembourrage et pieds

Cousin de l'assise en polyuréthane expansé en D30SPP indéformable. Coussins du dossier en D25M indéformable, le tout revêtu de voile associée thermiquement de 300 g. Version (B) coussin de l'accoudoir en D25 indéformable revêtu de voile associée thermiquement de 300 g. Pied en ABS noir de h 40 mm.

ALLISON style

L'arte è un modo per vincere la paura.

Art is a way to overcome fear.

L'art est un moyen de surmonter la peur. - Ettore Sottsass

Forme morbide e sobrie incorniciate con classe da un piedino angolare cromato dalla pregevole finitura. Allison è un divano ideale per arredare con gusto il centro stanza.

Soft and simple shapes, framed by classy angular feet with fine chrome finishes. Allison is an ideal sofa to furnish the centre of the room with taste.

Des formes moelleuses et sobres élégamment encadrées par des pieds angulaires chromés avec finitions de prestige. Allison est un canapé idéal pour meubler avec goût le centre de la pièce.



233



art. 07



PIEDINI CROMATI

I piedini cromati del divano definiscono i contorni dell'imbottito, rendendolo elegante e moderno, con un tocco glam.

CHROME FEET

The chrome feet of the sofa define the contours of the padding, making it stylish and modern, with a touch of glam.

PIEDS CHROMÉS

Les pieds chromés du canapé définissent les contours du corps rembourré, le rendant élégant et moderne, avec une touche de glamour.

214

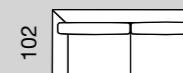

art. 06



Comprendere gli esseri umani è intelligenza, comprendere se stessi è saggezza.
Understanding other human beings is intelligence, understanding yourself is wisdom.
Comprendre les êtres humains relève de l'intelligence, se comprendre soi-même relève de la sagesse.

Leonardo da Vinci

251

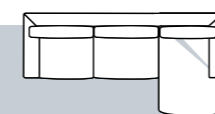

163

art. DS/SD

271

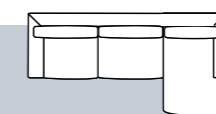

163

art. XL/LX



Poggiatesta - Headrest
 Appuie-Tête
 art. 31 optional

special
 price

Un tocco di classe con il piedino
angolare cromato.

A touch of class with its chrome
angular feet.

Une touche de classe avec
le pied angulaire chromé.

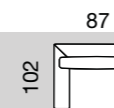

art. 01

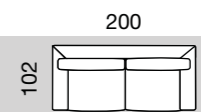

art. 03

PIÙ SPAZIO

Il divano è spesso un elemento irrinunciabile nelle nostre case, ma se dovete arredare un salotto piccolo può essere una buona idea anche sostituirlo (almeno in parte) con delle poltroncine: sono più versatili e più facili da spostare nelle occasioni in cui dovete rivoluzionare lo spazio, ad esempio per una cena con molti ospiti.

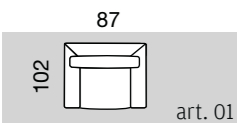

MORE ROOM

The sofa is often an essential element in our homes, but if you have to decorate a small living room, it can be a good idea to replace it (at least in part) with armchairs: they are more versatile and easier to move on those occasions when you need to revolutionize the space, such as a dinner with many guests.

PLUS D'ESPACE

Le canapé est souvent un élément essentiel dans nos maisons, mais si vous devez meubler un salon de petite taille, le remplacer par des fauteuils (au moins en partie) peut s'avérer une bonne idée : ils sont plus polyvalents et plus faciles à déplacer durant les occasions impliquant de révolutionner l'espace, par exemple lors d'un dîner avec de nombreux invités.

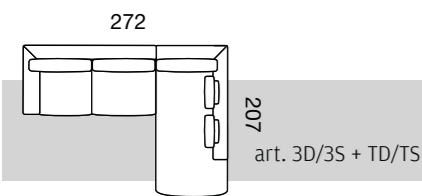

Il tempo che ti piace buttare, non è buttato.

Time you enjoy wasting, was not wasted.

Le temps que vous aimez perdre n'est pas du temps perdu.

John Lennon

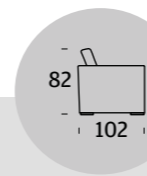

Art. 01
Poltrona
Armchair
Fauteuil

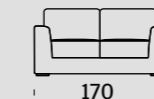

Art. 02
Divano 2 posti
2-seater sofa
Canapé 2 places

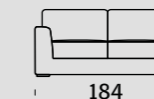

Art. 20
Divano 2 posti grande
2-seater large sofa
Canapé 2 places grand

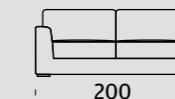

Art. 03
Divano 3 posti
3-seater sofa
Canapé 3 places

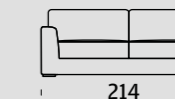

Art. 06
Divano 3 posti grande
3-seater large sofa
Canapé 3 places grand

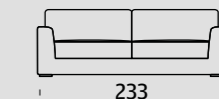

Art. 07
Divano 3 posti maxi
Maxi 3-seater sofa
Canapé 3 places maxi



Art. 09
Elemento centrale
Central element
Chausseuse



Art. 90
Elemento centrale maxi
Maxi central element
Chausseuse maxi



Art. 1D-1S
Laterale 1 posto DX-SX
RH-LH 1-seater side el.
Canapé bâtarde 1 place D-G



Art. 6D-6S
Laterale 1 posto grande DX-SX
RH-LH 1-seater large side el.
Canapé bâtarde 1 place grand D-G



Art. MD-MS
Laterale 1 posto maxi DX-SX
RH-LH maxi 1-seater side el.
Canapé bâtarde 1 place maxi D-G



Art. 2D-2S
Laterale 2 posti DX-SX
RH-LH 2-seater side el.
Canapé bâtarde 2 places D-G

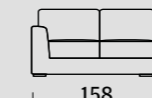

Art. GD-GS
Laterale 2 posti grande DX-SX
RH-LH 2-seater large side el.
Canapé bâtarde 2 places grand D-G

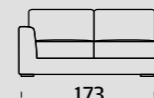

Art. 3D-3S
Laterale 3 posti DX-SX
RH-LH 3-seater side el.
Canapé bâtarde 3 places D-G



Art. KD-KS
Laterale 3 posti grande DX-SX
RH-LH 3-seater large side el.
Canapé bâtarde 3 places grand D-G

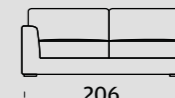

Art. 7D-7S
Laterale 3 posti maxi DX-SX
RH-LH maxi 3-seater side el.
Canapé bâtarde 3 places maxi D-G



Art. AQ
Angolo quadro
Square corner
Angle carré



Art. AA
Angolo aperto
Open corner
Angle ouvert

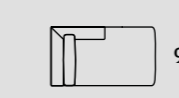

Art. CD-CS
Chaise longue reversibile DX-SX
RH/LH reversible chaise L.
Mérienne réversible D-G

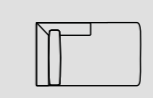

Art. CM-MC
Chaise longue reversibile Maxi DX-SX
RH-LH reversible maxi chaise L.
Mérienne maxi réversible D-G

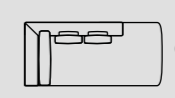

Art. TD-TS
Terminale DX-SX
RH-LH end element
Terminal D-G



Art. 13
Pouf rettangolare
Rectangular pouf
Pouf rectangulaire



Art. 14
Pouf con contenitore
Pouf with storage
Pouf avec niche de rangement

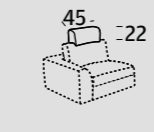

Art. 31
Poggiatesta
Headrest
Appuie-tête

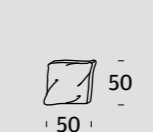

Art. 15
Cuscino a scatola "Allison"
Box pillow "Allison"
Coussin en forme de boîte "Allison"

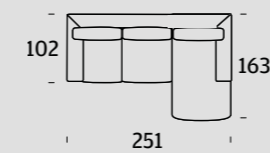

Art. DS-SD
Special con penisola
Special sofa with chaise
Special canapé avec chaise longue

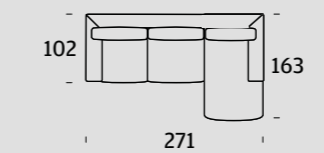

Art. XL-LX
Special con penisola maxi
Special maxi sofa with chaise
Special canapé maxi avec chaise longue

• LISTINO PREZZI / PRICE LIST / LISTE DES PRIX pag. 283

Struttura e molleggio

Realizzata con masselli portanti in legno di abete massiccio di vari spessori, parti di tamponamento in fibra grezza e/o compensato. Fianchi in agglomerato di legno da 18 mm. Fibra grezza e agglomerato di legno in classe E1, pertanto a bassa emissione di formaldeide. Il tutto rivestito con vellutino 100% poliammide termoaccoppiato ad espanso e/o ovatta in fibra di poliestere 100%. Molleggio realizzato con nastri elastici da 80 mm tesi meccanicamente e distanziati di circa 25 mm, composti da fili di gomma ricoperti da filo di nylon avvolto a spirale.

Imbottitura e piede

Cuscino seduta in espanso indeformabile D. SR35, rivestito in falda di poliestere 100% da 300 g termofissato. Schienale D16 morbido indeformabile rivestito in falda termofissata da 300 g con annegato nell'espanso pannello di fibra di legno a sostenere la parte alta del cuscino schiena. Elementi di tamponamento bracciolo e telaio in D30 indeformabile. Piede in legno massello tinto wengé con profilo in finitura cromo.

Structure and springing

Made with bearing parts made of solid fir wood, with various thicknesses, reinforcement parts made of rough fibre and/or plywood. Sides made of agglomerated chips with 18 mm thickness. Rough fibre and agglomerated chips of the E1 Class, and thus with low formaldehyde emission. The whole is covered in 100% polyamide velvetene thermocoupled to foam and/or wadding in 100% polyester fibre. Springing made of mechanically tightened elastic bands with 80mm thickness, with 25 cm of distance between one another, composed of rubber threads covered with nylon thread, coiled up in a spiral.

Upholstery and Foot

Seating pillow in D indeformable foam SR35, covered in 100% polyester lap, with 300 gr weight, thermofixed. D16 back, soft and indeformable, covered in thermofixed lap with 300 gr weight, embedded in foam, panel made of wood fibre that sustains the upper part of the back pillow. Reinforcing elements for the arm and frame with D30, indeformable. Foot made of wengé dyed heartwood with chrome finishes.

Structure et suspension

Réalisée avec des duramens portants en bois de sapin massif de plusieurs épaisseurs, parties de fileurs en fibre brute et/ou contreplaqué. Côtés en bois aggloméré de 18 mm. Fibre brute et bois aggloméré de classe E1, donc à basse émission de formaldéhyde. Le tout est revêtu de velours 100% polyamide associé thermiquement à l'expansé et/ou ouate en fibres de polyester 100%. Suspension réalisée avec des bandes élastiques de 80 mm, tendues mécaniquement et à une distance d'environ 22 mm, composées de fils de caoutchouc recouverts de fil de nylon enroulé en spirale.

Rembourrage et pieds

Coussin de l'assise en expansé indeformable D. SR35, revêtu de voile de polyester 100% de 300 g fixé thermiquement. Dossier D16 moelleux indeformable revêtu de voile de polyester de 300 g avec, plongé dans l'expansé, un panneau en fibre de bois pour soutenir la partie haute du coussin pour le dos. Éléments fileurs, accouder et cadre en D30 indeformable. Pied En bois massif peint wengé avec profil en finition chrome.

Ergonomia

Felis ha studiato tante soluzioni ergonomiche per darti un divano dove rilassarti: alti schienali, meccanismi relax e poggiatesta inclinabili.

Ergonomics

Felis studied many ergonomic solutions to give you a sofa where you can relax: high backrests, relaxation mechanisms, and reclining headrest.

Ergonomie

Felis a étudié de nombreuses solutions ergonomiques pour vous offrir un canapé sur lequel vous pourrez vous détendre : hauts dossiers, mécanismes relax et repose-tête inclinables.



www.felis.it



Felis

VINCENT

style

Vincent è un divano componibile con schienale alto ergonomico, dotato di piedini in ABS disponibili in due diverse finiture: color legno o alluminio, si adatta ad ogni tipo di ambiente, da quello moderno al più classico. Completamente sfoderabile, può essere dotato di un confortevole poggiatesta, ideale per il relax della schiena.

Vincent is a modular sofa with high ergonomic back, equipped with ABS feet available in two different finishes: wood or aluminium colour, it is suitable for any type of environment, from modern to classic. Completely removable, it can be equipped with a comfortable headrest, ideal for the relaxation of the back.

Vincent est un canapé modulaire au dossier haut ergonomique, doté de pieds en ABS disponibles en deux finitions différentes : couleur bois ou aluminium, pour s'adapter à tous les styles, du moderne au classique. Entièrement déhoussable, il peut être doté d'un confortable appui-tête, idéal pour la détente du dos.



 Poggiatesta - Headrest
Appui-Tête
art. 31 optional



special price

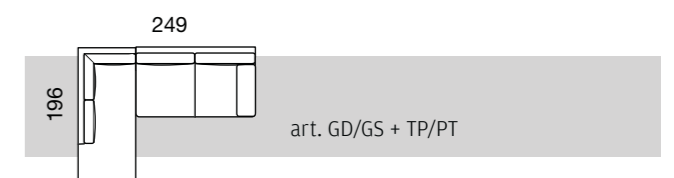
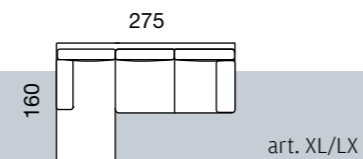
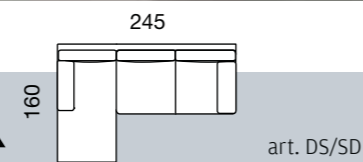

UN MONDO DI CUSCINI E POUF



Sono proprio gli accessori a popolare i nuovi soggiorni: cuscini formato "xl" o mignon, morbidi pouf, tavolini e così via. E se desideri cambiare aspetto alla casa scegli pattern e colori forti.

A WORLD OF CUSHIONS AND POUFS

It is the accessories that populate the new living-rooms: "xl" or extra-small cushions, soft poufs, coffee tables, and so on. And if you want to change the look of your house, choose strong patterns and colours.

UN MONDE DE COUSSINS ET DE POUFS

C'est bien les accessoires qui remplissent les nouveaux séjours : des coussins au format « XL » ou mini, des poufs moelleux, des tables basses et bien d'autres encore. Et si vous souhaitez changer le look de votre maison, choisissez des motifs et des couleurs fortes.

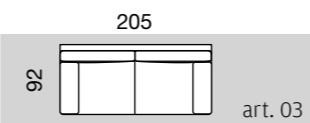

Voglio vedere cose. Questa è l'unica cosa con cui mi riesco a relazionare.

I want to see things. This is the only thing I can relate to.

Je veux voir des choses. C'est la seule chose à laquelle je peux m'identifier. - Carlo Scarpa

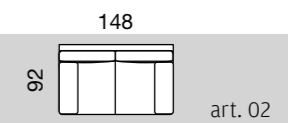

WENGÈ OPPURE ALLUMINIO?

Un divano che ti dà la possibilità di scegliere tra due stili. Opta per il piedino color alluminio se vuoi dare un tocco di modernità alla tua casa, preferiscilo in color wengè se cerchi di creare un'atmosfera più classica e di gran calore.

WENGÈ OR ALUMINIUM?

A sofa that gives you the possibility to choose between two styles. Opt for aluminium colour feet, if you want to give a modern touch to your home, prefer the wengè colour if you are trying to create a more classic and warmer atmosphere.

WENGÈ OU ALUMINIUM ?

Un canapé qui vous donne la possibilité de choisir entre deux styles. Optez pour des pieds couleur aluminium pour donner une touche de modernité à votre maison, ou choisissez les tons du wengè pour créer une atmosphère plus classique et chaleureuse.



172



art. 20



Il terminale ad angolo con penisola permette di sfruttare al meglio gli spazi, anche quando sono ridotti.

The corner terminal with peninsula, allows you to make the most of the space, even when it is small

L'extrémité en angle avec péninsule permet de tirer le meilleur parti de l'espace, même des plus réduits.

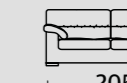
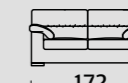
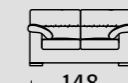
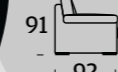

Art. 01
Poltrona
Armchair
Fauteuil

Art. 02
Divano 2 posti
2-seater sofa
Canapé 2 places

Art. 20
Divano 2 posti grande
2-seater large sofa
Canapé 2 places grand

Art. 03
Divano 3 posti
3-seater sofa
Canapé 3 places

Art. 09
Elemento centrale
Central element
Chaufeuse



Art. 1D-1S
Laterale 1 posto DX-SX
RH-LH 1-seater side el.
Canapé bâtarde 1 place D-G



Art. MD-MS
Laterale 1 posto maxi DX-SX
RH-LH maxi 1-seater side el.
Canapé bâtarde 1 place maxi D-G



Art. 2D-2S
Laterale 2 posti DX-SX
RH-LH 2-seater side el.
Canapé bâtarde 2 places D-G



Art. GD-GS
Laterale 2 posti grande DX-SX
RH-LH 2-seater large side el.
Canapé bâtarde 2 places grand D-G



Art. 3D-3S
Laterale 3 posti DX-SX
RH-LH 3-seater side el.
Canapé bâtarde 3 places D-G



Art. AQ
Angolo quadro
Square corner
Angle carré



Art. AT
Angolo aperto
Open corner
Angle ouvert

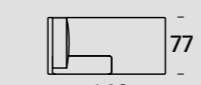

Art. CD-CS
Chaise longue reversibile DX-SX
RH-LH reversible chaise l.
Mériidienne réversible D-G

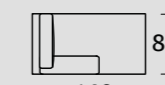

Art. CM-MC
Chaise longue reversibile maxi DX-SX
RH-LH reversible maxi chaise l.
Mériidienne réversible maxi D-G



Art. TD-TS
Terminale DX-SX
RH-LH end el.
Terminal D-G

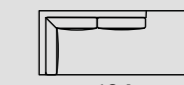

Art. TP-PT
Terminale angolo con penisola DX-SX
RH-LH end corner el. with peninsula el.
Terminal angle avec peninsula D-G

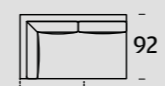

Art. TQ-QT
Terminale Angolo quadro DX-SX
RH-LH end square corner
Terminal angle carré D-G

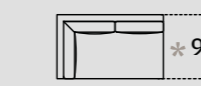

Art. LQ-QL
Laterale angolo quadro DX-SX
RH-LH square corner side el.
Canapé bâtarde angle carré D-G

* Lato componibile come da disegno
Modular side as per drawing
Côté modulable comme sur le dessin



Art. 14
Pouf rettangolare
Rectangular pouf
Pouf rectangulaire



Art. 31
Poggiatesta
Headrest
Appuie-tête
47x15xH13

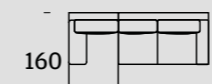

Art. DS-SD
Special con penisola
Special sofa with chaise
Special canapé avec chaise longue

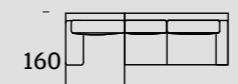

Art. XL-LX
Special con penisola maxi
Special maxi sofa with chaise
Special canapé maxi avec chaise longue

• LISTINO PREZZI / PRICE LIST / LISTE DES PRIX pag. 287

Struttura e molleggio

Struttura realizzata con masselli portanti in legno di pioppo o abete di vari spessori. Parti di tamponamento in fibra grezza e/o compensato di pioppo da mm 25. Fianchi in agglomerato di legno da 18 mm. Il tutto in classe E1, pertanto a bassa emissione di formaldeide, rivestito con vellutino 100% poliammide termoaccoppiato ad espanso e/o ovatta in fibra di poliestere 100%. Molleggio realizzato mediante nastri elastici da 80 mm tesi meccanicamente, composti da fili di gomma ricoperti da filo di nylon avvolto a spirale.

Imbottitura e piedi

Cuscino seduta in espanso indeformabile D30 rivestito con ovatta di fibra di poliestere siliconato da 300g. Cuscino schiena in espanso indeformabile D18 rivestito in resinato di poliestere da 200 g. Poggiatesta in espanso indeformabile D21 rivestito in resinato di poliestere da 200 g. Bracciolo in espanso indeformabile D25 rivestito in ovatta di poliestere siliconato da 300 g. Piedino in ABS color wengè o alluminio.

Structure and springs

Structure made with bearing parts in poplar or fir wood in various thicknesses. Reinforcing parts made of rough fibre and/or poplar plywood, 25 mm thick. Sides made of agglomerated chips, with 18 mm thickness. All this in compliance with Class E1 and thus with low formaldehyde emission, covered in 100% polyamide velvet, thermocoupled to foam and/or wadding in 100% polyester fibre. Spring made of mechanically tightened 80mm thick elastic bands, composed of rubber threads covered in nylon thread, coiled up in a spiral.

Upholstery and feet

Seating pillow in indeformable foam D30 covered in 300 g siliconized polyester fibre. Backrest pillow in indeformable foam D18 covered in 200 g polyester resinated. Leaning post for the lumbar area in indeformable foam D21 covered in 200 g polyester resinated. Armrest in indeformable foam D25 covered in 300 g siliconized polyester wadding. Wengè or aluminium colour ABS foot.

Structure et suspension

Structure réalisée en panneaux massifs de peuplier ou de sapin de différentes épaisseurs. Éléments de remplissage en fibre brute et/ou en contreplaqué de peuplier de 25 mm. Côtés en bois aggloméré de 18 mm, le tout de classe E1, donc à basse émission de formaldéhyde, revêtu de velours 100% polyamide associé thermiquement à l'expansé et/ou ouate en fibre de polyester 100%. Suspension réalisée à l'aide de sangles élastiques de 80 mm tendues mécaniquement, composées de fils de caoutchouc recouverts de fil de nylon enroulé en spirale.

Rembourrage et pieds

Coussin de l'assise en expansé indeformable D30 revêtu d'ouate en fibre polyester siliconé 300 g. Coussin dossier en expansé indeformable D18 revêtu de résine de polyester 200 g. Cale-reins en expansé indeformable D21 revêtu de résine de polyester 200 g. Accoudoir en expansé indeformable D25 revêtu d'ouate de polyester siliconé 300 g. Pieds en ABS couleur wengè ou aluminium.

JASPER

style

LA PAROLA ALL'ERGONOMIA

Una forma inconfondibile studiata per unire estetica e comfort. Con Jasper hai lo schienale alto e basso nello stesso divano. Completamente sfoderabile, è studiato per seguire l'ergonomia della nostra schiena e le tendenze dell'arredo contemporaneo.

THE WORD GOES TO ERGONOMICS

A unique shape, designed to combine aesthetics and comfort. Jasper allows you to have a high and a low backrest in the same couch. With its completely removable cover, it is designed to follow the ergonomics of our back, as well as the trends of contemporary furniture.

LA PAROLE À L'ERGONOMIE

Une forme unique conçue pour allier esthétique et confort. Avec Jasper, vous bénéficierez d'un dossier haut et bas sur le même canapé. Entièrement déhoussable, il est conçu pour suivre l'ergonomie de notre dos et les tendances du mobilier contemporain.

+DESIGN +COMFORT

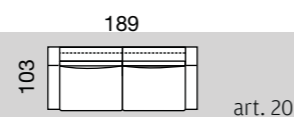

Dalla conchiglia si può capire il mollusco, dalla casa l'inquilino.

By the shell, you can understand the clam; by the house, the tenant.

De la coquille on peut comprendre le mollusque, de la maison, on peut comprendre qui l'habite. - Victor Hugo



THE STYLE GUIDE

Hi-tech, d'atmosfera o di design, le nuove collezioni di oggetti per la casa consentono di valorizzare gli ambienti che li ospitano, con la personalità del padrone di casa.

Whether they are hi-tech, mood evoking, or designer, the new collections of household items allow you to make the environments that host them more valuable, with the personality of the homeowner.

Haute technologie, ambiance et design, les nouvelles collections d'objets pour la maison permettent de valoriser les espaces qui les accueillent, selon la personnalité du maître de maison.

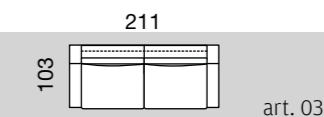

LA TUA SCHIENA RINGRAZIA



YOUR BACK WILL THANK YOU

Una forma inconfondibile, un benessere incredibile. A te la scelta se appoggiare o no la testa perché Jasper ti dà la possibilità di avere uno schienale alto, ergonomico e confortevole per le tue cervicali ma anche basso, per le soluzioni più formali in cui non è richiesto distendersi ma stare semplicemente seduti.

A distinctive shape, an amazing wellness. It is up to you whether to rest your head or not, because Jasper gives you the ability to have a high, ergonomic and comfortable backrest for your neck, but also a low one, for the more formal solutions where laying down is not required, but sitting is.

VOTRE DOS VOUS REMERCE

Une forme caractéristique, un bien-être incroyable. C'est vous qui décidez si vous préférez appuyer ou non votre tête car Jasper offre la possibilité de disposer à la fois d'un dossier haut, ergonomique et confortable pour votre cou, mais également un dossier bas, pour des solutions plus formelles ne nécessitant pas de se détendre, mais simplement d'être assis.



226

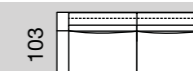

art. 07

COMFORT LINEARE

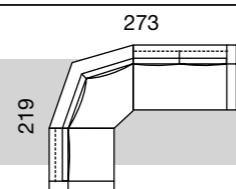

art. 2D/2S + AT + 1D/1S

Quando le sedute sono ampie, profonde il comfort si dilata e diventa extra large. Perfetto per vivere tutti i giorni con la tua famiglia, ideale per accogliere i tuoi ospiti.

LINEAR COMFORT

When the seats are wide and deep, comfort expands and becomes extra large. Perfect to live with your family every day, ideal to accommodate your guests.

CONFORT LINÉAIRE

Lorsque les assises sont amples et profondes, le confort se dilate et devient extra large. Parfait pour la vie de tous les jours avec votre famille, idéal pour accueillir vos invités.

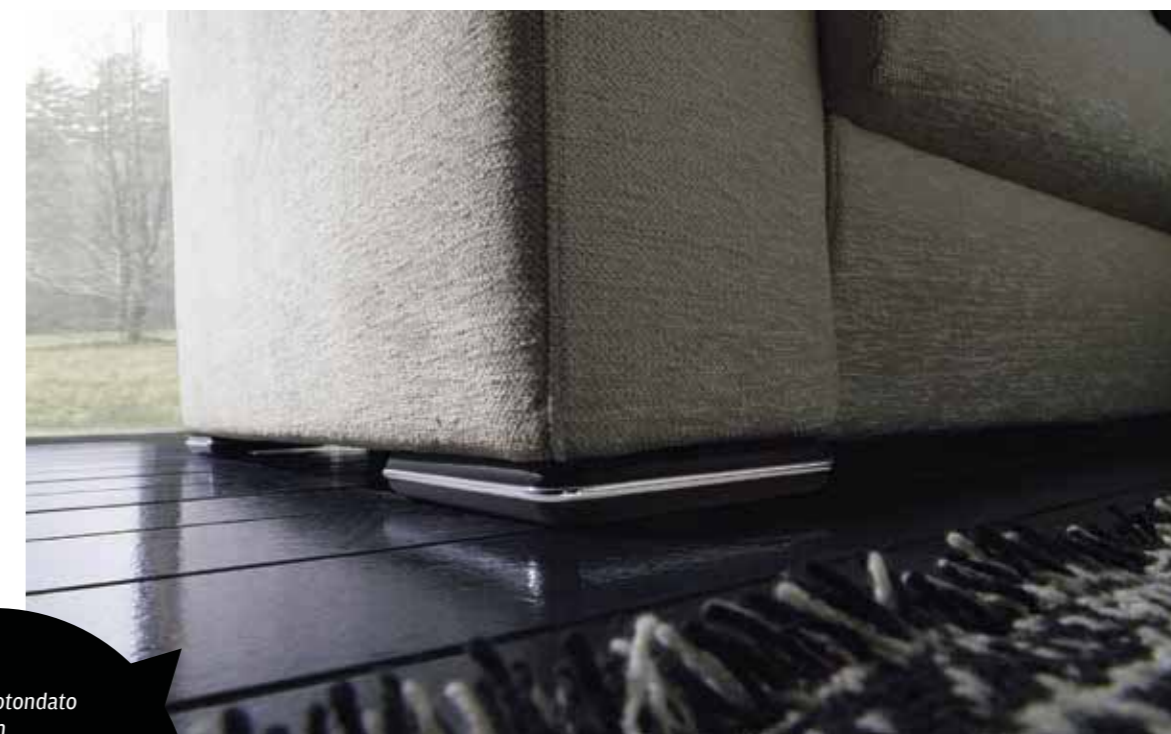

Antitacco arrotondato e piede design

Rounded heel-proof and designer feet

Protège-talon arrondi et pied design

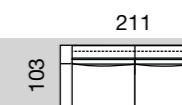

art. 03

THE TRANSFORMER SOFA



IL DIVANO TRASFORMISTA

Ami i divani bassi di design ma non intendi rinunciare al comfort? Jasper è il modello che fa per te. Lo schienale si trasforma e da basso diventa alto, in grado di accogliere la tua schiena nelle posizione più corretta. Perché la bellezza sposa la comodità.

THE TRANSFORMER SOFA

Do you like low designer sofas, but you do not intend to sacrifice comfort? Jasper is the right model for you. The backrest can be transformed from low to high, to accommodate your back in the most correct position. Because beauty meets comfort.

LE CANAPÉ TRANSFORMISTE

Vous aimez les canapés designs bas mais vous ne souhaitez pas sacrifier le confort? Jasper est fait pour vous. Le dossier se transforme et joue entre bas et haut, pour prendre soin de votre dos dans les positions correctes. Pour que la beauté épouse le confort.



special price

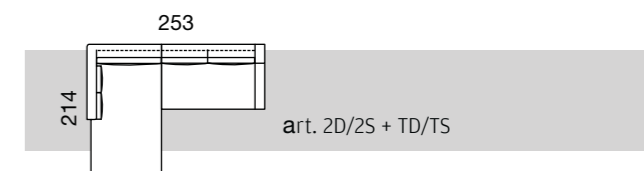
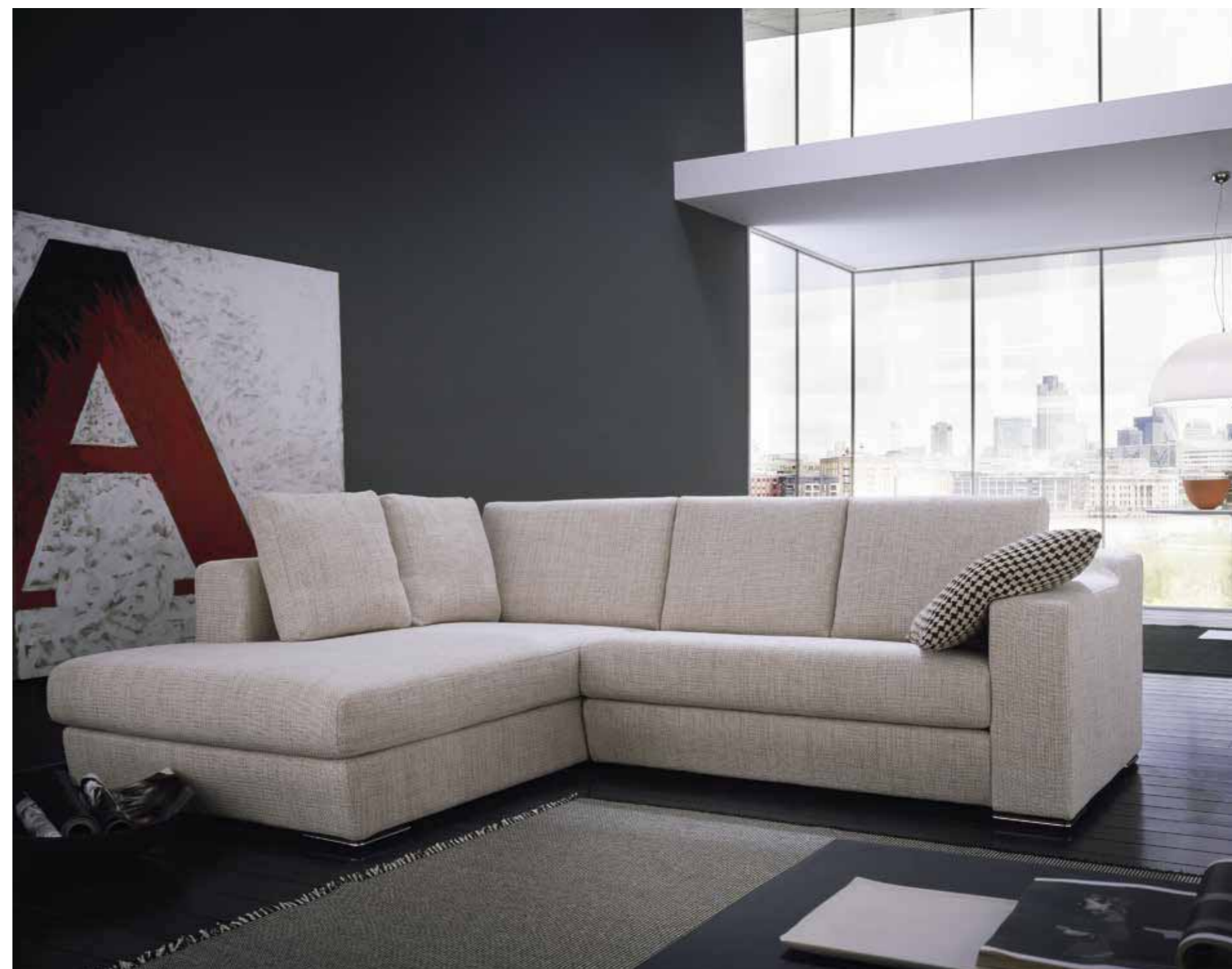
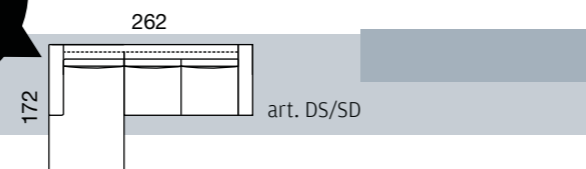



UNA VENTATA DI NUOVO

Non solo il colore delle pareti può dare un tocco di personalità all'arredo della tua casa. Ecco alcune idee originali: dai classici cuscini tinta unita o fantasia alle carte da parati o stickers. Oggetti d'arredo che possono "vestire" il tuo ambiente di una ventata di nuovo.

A BREATH OF FRESH AIR

It's not just the colour of the walls, that can give a personal touch to your home decor. Here are some ideas: from the classic plain or patterned cushions, to wallpaper, or stickers. Decorative objects that can "dress up" your environment, giving it a breath of fresh air.

UN SOUFFLE NOUVEAU

La couleur des murs n'est pas la seule à pouvoir donner une touche de personnalité au décor de votre maison. Voici quelques idées originales : des classiques coussins unis ou à motifs aux papiers peints ou autocollants. Des objets décoratifs capables d'« habiller » votre espace avec un souffle nouveau.



226

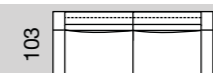

art. 07

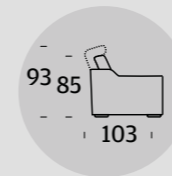

115
Art. 01
Poltrona
Armchair
Fauteuil



169
Art. 02
Divano 2 posti
2-seater sofa
Canapé 2 places

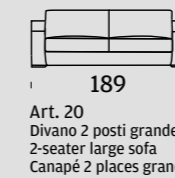

189
Art. 20
Divano 2 posti grande
2-seater large sofa
Canapé 2 places grand



211
Art. 03
Divano 3 posti
3-seater sofa
Canapé 3 places



226
Art. 07
Divano 3 posti maxi
Maxi 3-seater sofa
Canapé 3 places maxi

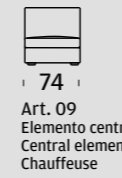

74
Art. 09
Elemento centrale
Central element
Chausseuse



85
Art. 90
Elemento centrale maxi
Maxi central element
Chausseuse maxi

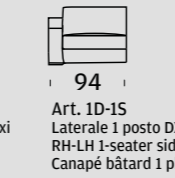

94
Art. 1D-1S
Laterale 1 posto DX-SX
RH-LH 1-seater side el.
Canapé bâtarde 1 place D-G

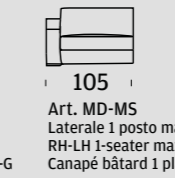

105
Art. MD-MS
Laterale 1 posto maxi DX-SX
RH-LH 1-seater maxi side el.
Canapé bâtarde 1 place maxi D-G

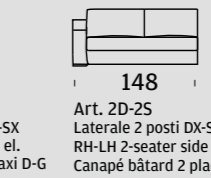

148
Art. 2D-2S
Laterale 2 posti DX-SX
RH-LH 2-seater side el.
Canapé bâtarde 2 places D-G



168
Art. GD-GS
Laterale 2 posti grande DX-SX
RH-LH 2-seater large side el.
Canapé bâtarde 2 places grand D-G

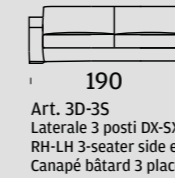

190
Art. 3D-3S
Laterale 3 posti DX-SX
RH-LH 3-seater side el.
Canapé bâtarde 3 places D-G

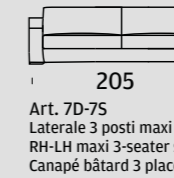

205
Art. 7D-7S
Laterale 3 posti maxi DX-SX
RH-LH maxi 3-seater side el.
Canapé bâtarde 3 places maxi D-G



125
Art. AT
Angolo tondo
Round corner
Angle rond



94
172
Art. CD-CS
Chaise longue DX-SX
RH/LH chaise L.
Méristienne D-G

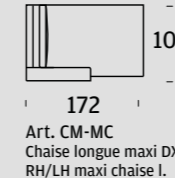

105
172
Art. CM-MC
Chaise longue maxi DX-SX
RH/LH maxi chaise L.
Méristienne maxi D-G

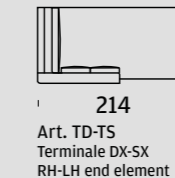

105
214
Art. TD-TS
Terminale DX-SX
RH-LH end element
Terminal D-G

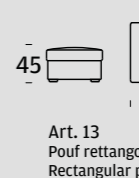

45
75
86
Art. 13
Pouf rettangolare
Rectangular pouf
Pouf rectangulaire

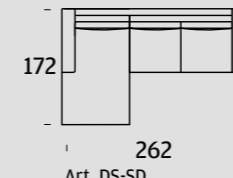

172
262
Art. DS-SD
Special con penisola
Special sofa with chaise
Special canapé avec chaise longue

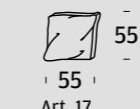

55
55
Art. 17
Cuscino a scatola "Jasper"
Box pillow "Jasper"
Coussin en forme de boîte "Jasper"

• LISTINO PREZZI / PRICE LIST / LISTE DES PRIX pag. 290

Struttura e molleggio

Struttura realizzata con masselli portanti in legno di abete massiccio di vari spessori, parti di tamponamento in fibra grezza e/o compensato. Fianchi in agglomerato di legno da 18 mm. Fibra grezza e agglomerato di legno in classe E1, pertanto a bassa emissione di formaldeide. Il tutto rivestito con vellutino 100% poliammide termoaccoppiato ad espanso e/o ovatta in fibra di poliestere 100%. Molleggio realizzato con nastri elastici da 80 mm tesi meccanicamente, composti da fili di gomma ricoperti da filo di nylon avvolto a spirale.

Imbottitura e piedi

Cuscino seduta in poliuretano espanso indeformabile D35FR rivestito con teknoform 280 g termofissato a vellutino. Cuscino schienale in espanso indeformabile D18-55 rivestito con resinato di poliestere 100 g termofissato a vellutino. Poggiatesta in espanso indeformabile doppia D30 e FEE 21 rivestito con resinato di poliestere 100 g termofissato a vellutino. Elementi di tamponamento in D30 indeformabile. Piede in legno massello tinto wengé con profilo ABS finitura cromo.

Structure and springs

Structure made with bearing parts made of solid fir heartwood, with various thicknesses, reinforcement parts made of rough fibre and/or plywood. Sides made of agglomerated chips with 18 mm thickness. Rough fibre and agglomerated chips of the E1 Class, and thus with low formaldehyde emission. The whole is covered in 100% polyamide velveteen thermocoupled to foam and/or wadding in 100% polyester fibre. Spring made of mechanically tightened elastic bands with 80 mm thickness, composed of rubber threads covered with nylon thread, coiled up in a spiral.

Upholstery and feet

Seating pillow made of D35FR indeformable polyurethane foam, covered in 280 gr teknoform thermofixed to velveteen. Back pillow in indeformable foam D18-55 covered in polyester resinat with 100 gr weight, thermofixed to velveteen. Headrest made of indeformable foam, with double D30 and FEE 21, covered in polyester resinat with 100 gr weight, thermofixed to velveteen. Reinforcing elements with D30, indeformable. Foot made of wengé dyed heartwood in ABS with chrome profile finishes.

Structure et suspension

Structure réalisée avec des duramens portants en bois de sapin massif de plusieurs épaisseurs, parties de fileurs en fibre brute et/ou contreplaqué. Côtés en bois aggloméré de 18 mm. Fibre brute et bois aggloméré de classe E1, donc à basse émission de formaldéhyde. Le tout est revêtu de velours 100% polyamide associé thermiquement à l'expansé et/ou ouate en fibres de polyester 100%. Suspension réalisée avec des bandes élastiques de 80 mm, tendues mécaniquement, composées de fils de caoutchouc recouverts de fil de nylon enroulé en spirale.

Rembourrage et pieds

Coussin de l'assise en polyuréthane expansé indeformable D35FR, revêtu de teknoform 280 g fixé thermiquement au velours. Coussin du dossier en expansé indeformable D18-55 revêtu de résine de polyester 100 g fixé thermiquement au velours. Appuie-tête en expansé indeformable double D30 et FEE 21 revêtu de résine de polyester 100 g fixé thermiquement au velours. Éléments fileurs de D30 indeformable. Pied en bois massif peint wengé avec profil ABS en finition chrome.

RUSSEL

style

L'architettura non è altro che l'ordine, la disposizione, la bella apparenza, la proporzione delle parti tra loro, la convenienza e la distribuzione.
Architecture is nothing but the order, arrangement, beautiful appearance, proportion of parts, convenience, and distribution.

L'architecture n'est rien d'autre que l'ordre, la disposition, la belle apparence, la proportion des éléments entre eux, la commodité et la distribution.

Michelangelo Buonarroti

ROTONDE ARMONIE

Te ne staresti ore e ore disteso sul tuo divano? Allora Russel è il divano ideale. Il suo schienale morbidissimo ti avvolgerà come un guscio.

ROUND HARMONY

Would you spend hours and hours lying on your sofa? In that case, Russell is your ideal sofa. Its extremely soft backrest will wrap you like a soft shell.

LA RONDEUR DES HARMONIES

Vous resteriez allongé dans votre canapé pendant des heures et des heures ? Alors Russell est le canapé idéal. Son dossier moelleux vous enveloppera comme une coquille.



Ricordati di giocare con complementi d'arredo dalle cromie a contrasto. Otterrai un living minimal ma sofisticato.

Remember to play with a contrasting colour decor. You'll get a minimal, yet sophisticated, living area.

N'oubliez pas de jouer avec des éléments de décor aux couleurs contrastées. Votre salon sera minimal et sophistiqué.

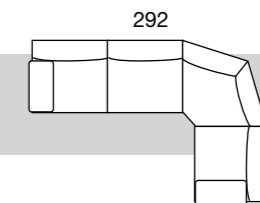

art. 3D/3S + AA + MD/MS



La creatività non sta nel trovare nuovi paesaggi, ma nell'avere occhi nuovi.
Creativity is not in finding new landscapes, but in having new eyes.
Le véritable voyage de découverte ne consiste pas à chercher de nouveaux paysages, mais à avoir de nouveaux yeux. - Marcel Proust

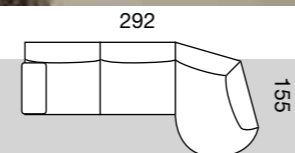

art. 3D/3S + LT/TL



art. PA
 Pouf anteriore - Front pouf - Pouf avant



La nostra meta non è mai un luogo, ma piuttosto un nuovo modo di vedere le cose.

One's destination is never a place, but a new way of seeing things.

Notre destination n'est jamais un lieu, mais bien une nouvelle façon de voir les choses. - Henry Miller

special
price

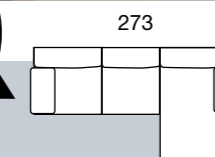

165

art. XL/LX

A TUTTA CURVA

Le linee morbide e confortevoli invogliano a sedersi, a riposare e aiutano a sfruttare meglio gli spazi. Russell è come una nuvola, un soffice abbraccio.

FULL CURVE

The smooth and comfortable lines invite you to sit down, to rest. They also help you to make better use of the space. Russell is like a cloud, a soft embrace.

DES COURBES SANS LIMITES

Les lignes douces et confortables invitent à s'asseoir, à se reposer. Et elles aident à tirer le meilleur parti de l'espace. Russell est comme un nuage, une douce étreinte.



special price

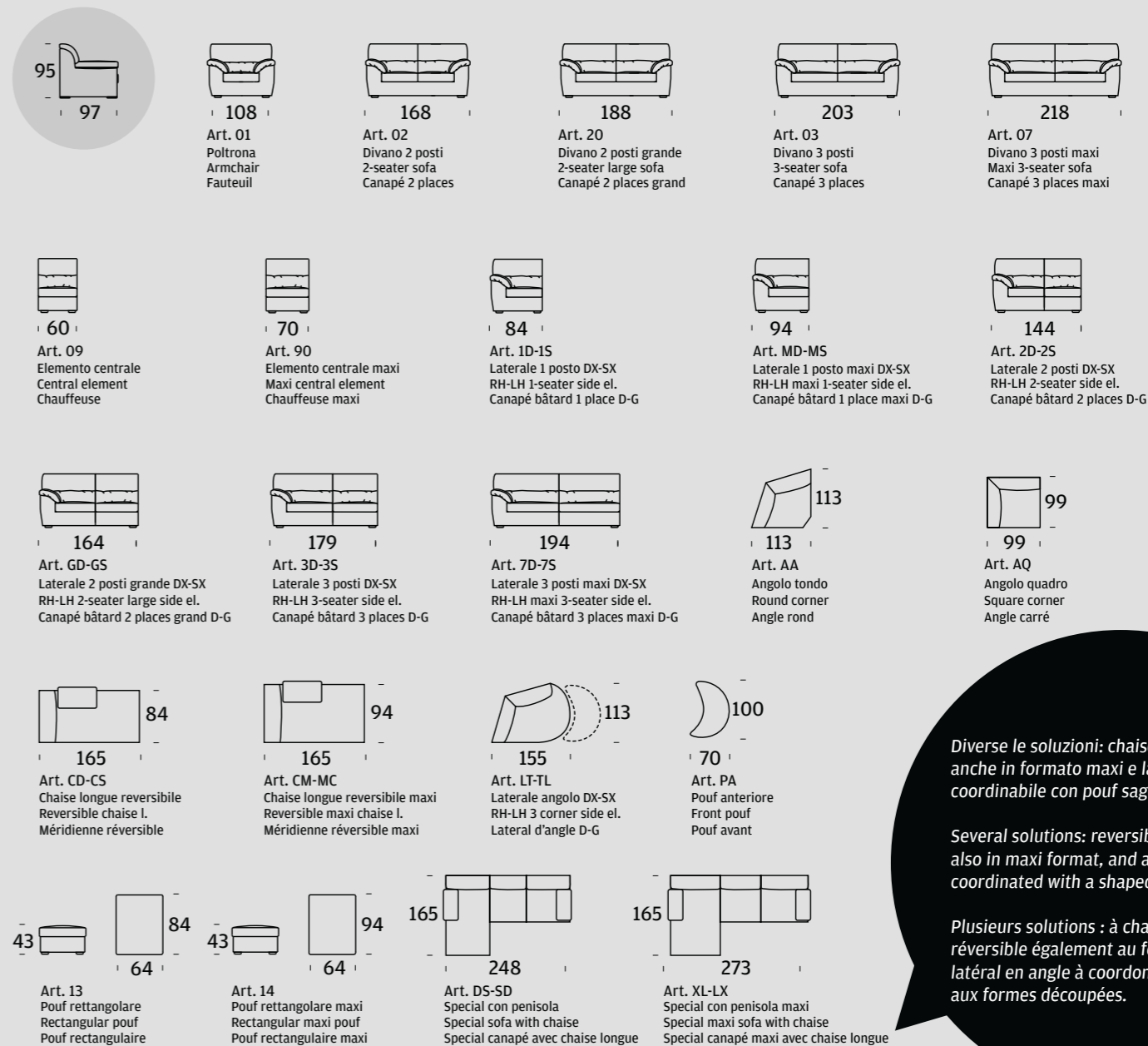
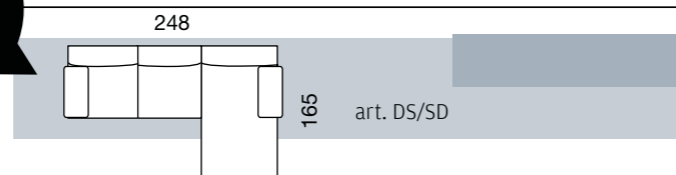

• LISTINO PREZZI / PRICE LIST / LISTE DES PRIX pag. 293

Diverse le soluzioni: chaise longue reversibile anche in formato maxi e laterale ad angolo coordinabile con pouf sagomato.

Several solutions: reversible chaise longue, also in maxi format, and angled side coordinated with a shaped pouf.

Plusieurs solutions : à chaise longue réversible également au format maxi et latéral en angle à coordonner avec un pouf aux formes découpées.

Struttura e molleggio

La struttura è realizzata con masselli portanti in legno di pino o abete di vari spessori. Parti di tamponamento in fibra grezza e/o compensato. Fianchi in agglomerato di legno da 18 mm. Fibra grezza e agglomerato di legno appartengono alla classe E1, pertanto sono a bassa emissione di formaldeide. Il tutto è rivestito in vellutino 100% poliammide termoaccoppiato ad espanso e/o ovatta in fibra poliestere 100% resinata. Molleggio realizzato con nastri elastici da 80 mm tesi meccanicamente, composti da fili di gomma ricoperti da filo di nylon avvolto a spirale. Gli schienali montano invece un nastro da 50 mm.

Imbottitura e piedi

Cuscino seduta in espanso indeformabile D30 e rivestiti con ovatta di fibra poliestere da 200 g resinata. Cuscino schienale in espanso indeformabile D18 e rivestito con ovatta di fibra di poliestere da 100 g resinata. Cuscino bracciolo D18 e poggiatesta in fiocco di poliestere cava siliconata 100% vergine, contenuta da rivestimento in TNT 50 g. Piedi in legno tinto wengé con profilo in metallo.

Structure and springs

Made with bearing parts in poplar or fir wood in various thicknesses. Reinforcing parts in rough fibre and/ or plywood. Sides made of 18 mm thick agglomerated wood chips. Rough fibre and agglomerated chips in the E1 class, therefore with a low formaldehyde emission. The whole is covered in 100% polyamide velveteen thermocoupled to foam and/or 100% resin polyester fibre wadding. Springs made of mechanically tightened 80mm thick elastic bands, composed of rubber threads covered with nylon thread, coiled up in a spiral. The backs, on the contrary, are equipped with a 50 mm band.

Upholstery and feet

Seating cushion in indeformable foam with D30 and covered in 200 g resinate polyester lap wadding. Backrest cushion in indeformable foam with D18 and covered in 100 g resinate polyester lap wadding. Armrest cushion D18 and leaning post for the lumbar area made of 100% virgin silicone hollow polyester flakes, in a 50 g TNT cover. Feet in wengé stained wood with metal profile.

Structure et suspension

La structure est réalisée en panneaux massifs de peuplier ou de sapin de différentes épaisseurs. Parties de fileurs en fibre brute et/ ou contreplaqué. Côtés en bois aggloméré de 18 mm. La fibre brute et le bois aggloméré appartiennent à la classe E1 et donc ils sont à basse émission de formaldéhyde. Le tout est revêtu de velours 100% polyamide associé thermiquement à l'expansé et/ou à la ouate en fibres de polyester 100% résine. Suspension réalisée à l'aide de sangles élastiques de 80 mm tendues mécaniquement, composées de fils de caoutchouc recouverts de fil de nylon enroulé en spirale. Les dossiers montent une sangle de 50 mm.

Rembourrage et pieds

Coussin de l'assise en expansé indéformable D30 et revêtu de ouate de fibre polyester de 200 gr résine. Coussin du dossier en expansé indéformable D18, et revêtu de ouate de fibre polyester de 100 gr résine. Coussin de l'accoudoir D18 et cale-reins en flocon de polyester creux siliconé 100% vierge, contenu dans le revêtement en TNT 50 g. Pieds en bois teinté wengé avec profil en métal.

DOMINO

style

PERFETTO OVUNQUE

Volumi leggeri e sottile gioco di proporzioni: Domino è il divano perfetto per arredare le case e gli appartamenti d'oggi, anche quando hanno dimensioni contenute.

PERFECT EVERYWHERE

Light volumes and a fine game of proportions: Domino is the perfect sofa to furnish the homes and apartments of today, even when they are small in size.

PARFAIT N'IMPORTE OÙ

Des volumes légers et un subtil jeu de proportions : Domino est le canapé idéal pour meubler les maisons et les appartements d'aujourd'hui, même lorsqu'ils sont de petite taille.

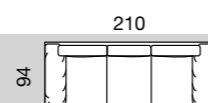

art. 03

Un designer dovrebbe sapere che gli oggetti possono diventare lo strumento di un rito esistenziale.

A designer should know that objects can become the instrument of a rite of existence.

Le designer devrait savoir que les objets peuvent devenir l'instrument d'un rite existentiel. - Ettore Sottsass



IL SEGRETO STA NELLO SCHIENALE

Lo schienale alto di 98 cm è ideale per assumere la posizione corretta e favorire un perfetto relax. La vostra schiena vi ringrazierà.

THE SECRET IS IN THE BACKREST

The 98 cm high backrest is ideal to assume the proper position and facilitate perfect relaxation. Your back will thank you.

LE SECRET EST DANS LE DOSSIER

Le dossier haut de 98 cm est idéal pour une position correcte et pour favoriser une détente parfaite. Votre dos vous remerciera.

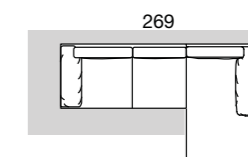

art. GD/GS + CM/MC

La soluzione 1 è caratterizzata da un divano angolare con terminale arrotondato, utile per ottimizzare gli spazi, schienale alto ergonomico, sfoderabilità totale.

Solution #1 is characterized by a corner sofa with a rounded terminal, useful to optimize space, a ergonomic high back, completely removable covers.

La solution n°1 se caractérise par un canapé d'angle avec extrémité arrondie, utile pour optimiser l'espace, avec un dossier haut ergonomique et entièrement déhoussable.

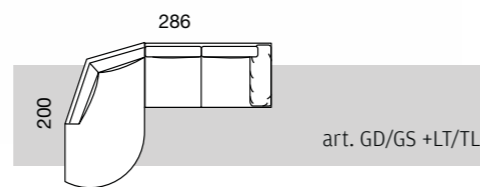
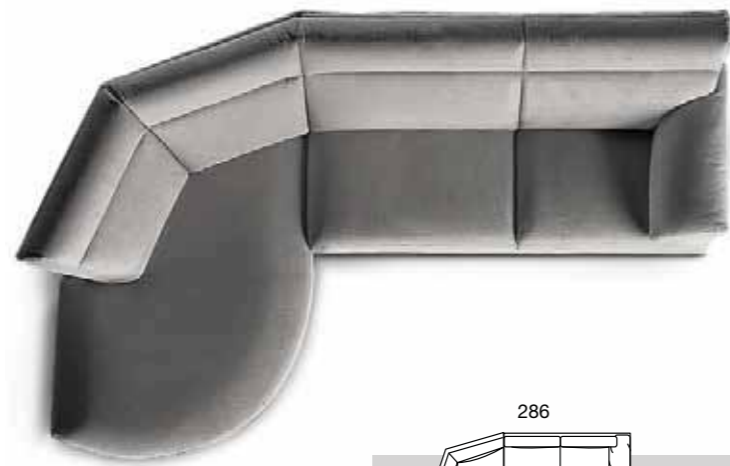

La soluzione 2 presenta un laterale angolo quadro, perfetto anche per un relax a due, sfoderabilità totale

Solution #2 is characterized by a square angled side, also perfect for relaxing in two, completely removable covers

La solution n°2 propose un angle latéral carré, parfait également pour un moment de détente à deux, entièrement déhoussable.

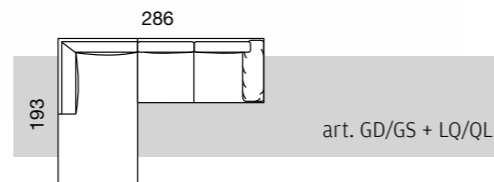
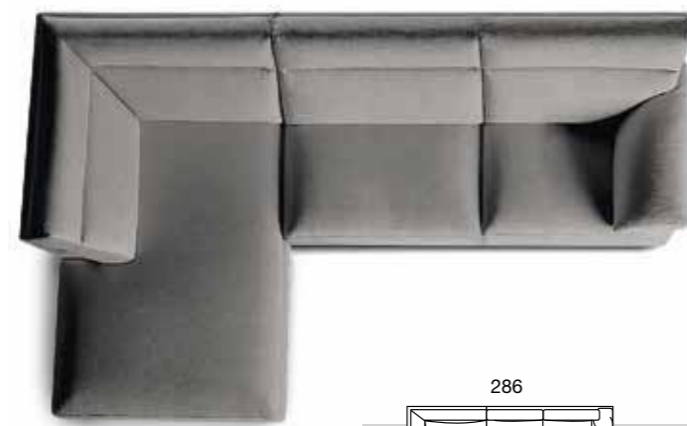

La soluzione 3 ha un carattere più minimal: dotata di chaise longue, ha profondità più ristrette, sfoderabilità totale.

La soluzione 3 ha un carattere più minimal: dotata di chaise longue, ha profondità più ristrette, sfoderabilità totale.

La solution n°3 est plus minimaliste : avec sa chaise longue, sa profondeur est plus restreinte, entièrement déhoussable.

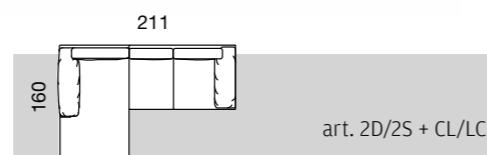

Lo stile e il design sono importanti ma non trascurate il comfort. Lascia che sia il tuo corpo a decidere. Su Domino grazie al suo schienale alto ergonomico potrai abbandonare il capo all'indietro in una posizione perfetta per godersi un sano relax.

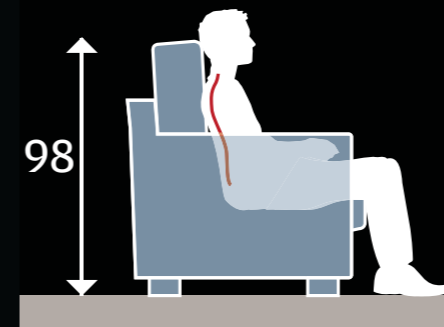

ERGONOMICS! FIRST OF ALL

Style and design are important, but you should not neglect comfort. Let your body decide. Thanks to Domino's ergonomic high back, you can drop your head back in a perfect position to enjoy healthy relaxation.

ERGONOMIE ! AVANT TOUT

Le style et le design sont importants, mais le confort ne doit pas être négligé. Laissez votre corps décider. Avec Domino, grâce à son haut dossier ergonomique, vous pourrez abandonner votre tête en arrière dans une position parfaite pour profiter d'un moment de saine détente.

ERGONOMIA! PRIMA DI TUTTO

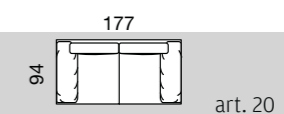

Percepire un aspetto nuovo di sé stessi è il primo passo verso il cambiamento del concetto di sé.

To perceive a new aspect of oneself is the first step toward changing the concept of oneself.

Percevoir un nouvel aspect de vous-même est le premier pas vers le changement du concept de soi. - Carl Rogers



CORNER COMFORT

Un divano ad angolo, con le sue innumerevoli opzioni, è un ottimo modo per sfruttare al meglio il vostro spazio. Perfetto per famiglie e persone che amano stare in compagnia o per quelli che desiderano sdraiarsi sulle sue comode penisole.

A corner sofa, with its many options, is a great way to make the most of your space. Perfect for families and people who love gathering together, or for those who want to lie down on its comfortable peninsulas.

Un canapé d'angle, avec ses nombreuses options, est un excellent moyen de tirer le meilleur parti de votre espace. Parfait pour les familles et les personnes qui aiment recevoir ou pour qui souhaite pouvoir s'allonger sur les confortables péninsules.



	Art. 01 Poltrona Armchair Fauteuil	Art. 02 Divano 2 posti 2-seater sofa Canapé 2 places	Art. 20 Divano 2 posti grande 2-seater large sofa Canapé 2 places grand	Art. 03 Divano 3 posti 3-seater sofa Canapé 3 places	Art. 09 Elemento centrale Central element Chaufeuse	Art. 90 Elemento centrale maxi Maxi central element Chaufeuse maxi
Art. 1D-1S Laterale 1 posto DX-SX RH-LH 1-seater side el. Canapé bâtarde 1 place D-G	Art. MD-MS Laterale 1 posto maxi DX-SX RH-LH maxi 1-seater side el. Canapé bâtarde 1 place maxi D-G	Art. 2D-2S Laterale 2 posti DX-SX RH-LH 2-seater side el. Canapé bâtarde 2 places D-G	Art. GD-GS Laterale 2 posti grande DX-SX RH-LH 2-seater large side el. Canapé bâtarde 2 places grand D-G	Art. 3D-3S Laterale 3 posti DX-SX RH-LH 3-seater side el. Canapé bâtarde 3 places D-G		
Art. AQ Angolo quadro Square corner Angle carré	Art. AT Angolo tondo Round corner Angle rond	Art. CL-LC Chaise longue reversibile DX-SX RH/LH reversible chaise l. Mériidienne réversible D-G	Art. CM-MC Chaise longue reversibile maxi DX-SX RH/LH reversible maxi chaise l. Mériidienne réversible maxi D-G	Art. P1-1P Penisola laterale DX-SX RH-LH side peninsular el. Peninsule latéral D-G		
Art. TO-OT Terminale tondo DX-SX RH-LH round end el. Terminal rond D-G	Art. LQ-QL Laterale angolo quadro DX-SX RH-LH square corner side el. Canapé bâtarde angle carré D-G	Art. LT-TL Laterale angolo tondo DX-SX RH-LH round corner side el. Canapé bâtarde angle rond D-G	Art. TD-TS Terminale DX-SX RH-LH end el. Terminal D-G	Art. 13 Pouf quadrato Square pouf Pouf carré		

• LISTINO PREZZI / PRICE LIST / LISTE DES PRIX pag. 296

Struttura e molleggio

Struttura realizzata con masselli portanti in legno di pioppo o abete di vari spessori. Parti di tamponamento in fibra grezza e/o compensato. Fianchi in agglomerato di legno da 18 mm. Fibra grezza e agglomerato di legno appartengono alla classe E1, pertanto a bassa emissione di formaldeide, termoaccoppiato ad espanso e/o ovatta di fibra poliestere 100% resinata.

Molleggio realizzato con nastri elastici da 80 mm tesi meccanicamente, composti da fili di gomma ricoperti da filo di nylon avvolto a spirale.

Imbottitura e piedi

Cuscino seduta in espanso indeformabile in D35 e cuscino schienale in espanso D18, entrambi rivestiti con ovatta di fibra di poliestere da 300 g termolegata. Cuscino bracciolo in espanso D18 rivestito da ovatta di fibra poliestere da 300 g termolegata. Sagomati vari a completamento in espanso D40.

Piede in legno finitura ciliegio, wengé, alluminio.

Structure and springs

Structure made with bearing parts in poplar or fir wood in various thicknesses. Reinforcing parts made of rough fibre and/ or plywood. Sides in 18 mm agglomerated wood chips. Rough fibre and the agglomerated wood chips are in class E1 thus with a low formaldehyde emission; thermocoupled to foam and/or 100% resinated polyester fibre wadding.

Springs made of mechanically tightened 80 mm thick elastic bands, composed of rubber threads covered with nylon thread, coiled up in a spiral.

Upholstery and feet

Seat cushion in D35 non deformable foam and backrest cushion in D18 foam - both covered with 300 g of thermobonded polyester fibre wadding. Armrest cushion in D18 foam covered with 300 g thermobonded polyester fibre wadding. Various shaped elements in foam to complete with a D40.

Wood foot with cherry, wengé or aluminium finish.

Structure et suspension

Structure réalisée en panneaux massifs de peuplier ou de sapin de différentes épaisseurs. Éléments de remplissage en fibre brute et/ou en contreplaqué. Côtés en bois aggloméré de 18 mm. Fibre brute et bois aggloméré de classe E1, donc à basse émission de formaldéhyde, thermiquement associé à expansé et/ou à ouate 100% fibre de résine polyester.

Suspension réalisée à l'aide de sangles élastiques de 80 mm tendues mécaniquement, composées de fils de caoutchouc recouverts de fil de nylon enroulé en spirale.

Rembourrage et pieds

Coussin d'assise en expansé indéformable de D35 et coussin de dossier en expansé de D18, tous deux revêtus d'ouate de fibre polyester de 300 g associée thermiquement. Coussin accoudoir en expansé de D18 revêtu d'ouate de fibre polyester de 300 g associée thermiquement. Différents modèles en complément en expansé de D40.

Pied en bois en finition merisier, wengé, aluminium.

MAXIMÉ

style

LOOK GEOMETRICO.

Forme squadrate, braccioli importanti, sedili soffici: Maximé invita a fare del divano il posto su cui trascorrere molti momenti della giornata, senza timore di rovinarlo. La geometria del comfort sta nel punto di intersezione di quattro elementi: bracciolo, schienale, seduta e cuscino. Lì c'è la sintesi di ogni divano.

GEOMETRIC LOOK.

Squared shapes, imposing armrests, soft seats: Maximé invites us to make the sofa a place where to spend many moments of our day without the fear of ruining it. The geometry of comfort is the intersecting point of the four elements: armrest, back, seat, and cushion. That is where the synthesis of each sofa lies.

LOOK GÉOMÉTRIQUE.

Des formes carrées, des accoudoirs importants, des assises moelleuses: Maximé invite à faire du canapé l'acteur de nombreux moments de la journée, sans crainte de l'abîmer. La géométrie du confort se trouve à l'intersection de quatre éléments: l'accoudoir, le dossier, l'assise et le coussin. C'est là que réside la synthèse de chaque canapé.



Di sicuro effetto la scelta di abbinarne più di un pouf.

Highly effective, the choice to pair it with multiple poufs.

Un choix très efficace celui d'associer plusieurs poufs.

Pouf collection pag. 236



L'idea di un architetto non è mai solo formale. Deve essere al tempo stesso sociale, scientifica e poetica.
The idea of an architect is never merely formal. It must be at the same time social, scientific and poetic.
L'idée d'un architecte n'est jamais purement formelle. Elle doit être à la fois sociale, scientifique et poétique.

Renzo Piano

New!

Scopri la nuova collezione di cuscini a pagina 245, tante proposte per un tocco di personalità.

Discover the new collection of cushions on page 245, many proposals for a touch of personality.

Découvrez la nouvelle collection de coussins à la page 245, de nombreuses propositions pour une touche de personnalité.



194

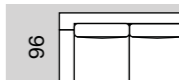

art. 20

SINUOSO DESIGN

La geometricità delle forme di Maximè viene smorzata nel divano angolare con terminale arrotondato. Una sinuosa curva per sedurre i tuoi ospiti e dare un tocco di femminilità al tuo soggiorno.

SINUOUS DESIGN

The regular shapes of Maximè are damped in a corner sofa with rounded end. A sinuous curve to seduce your guests and give a touch of femininity to your living room.

DESIGN SINUEUX

Les formes régulières de Maximè sont adoucies sur le canapé d'angle à l'extrémité arrondie. Une courbe sinueuse pour séduire vos invités et donner une touche de féminité à votre salon.



Il pouf: un ottimo complemento per aggiungere posti.

The pouf: an excellent accessory to add a seat.

Le pouf: un excellent complément pour des places supplémentaires.

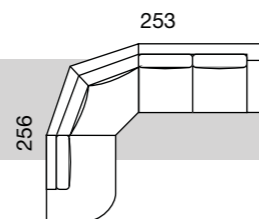

256

253

art. 2D/2S + AT + PD/PS



Con il divano ad angolo tondo recuperi spazio sul retro dell'imbottito.

With the round corner sofa, you will gain space on the back of the padding.

Avec le canapé d'angle arrondi, vous gagnerez de l'espace à l'arrière du meuble.



STILE E PERSONALITÀ

Oggi il living è una vetrina di stile e personalità sempre aggiornata, con il catalogo dell'ultima mostra sul tavolino di fronte al divano e la rivista di punta sullo scaffale di fianco ai libri.

STYLE AND PERSONALITY

Today, the living area is a showcase of style and always up to date personality, with the latest exhibition catalogue on the coffee table in front of the sofa, and the flagship magazine on the shelf next to the books.

STYLE ET PERSONNALITÉ

Aujourd'hui, le salon est une vitrine de style et de personnalité toujours actualisée avec le catalogue de la dernière exposition sur la table basse devant le canapé et le magazine phare sur l'étagère à côté des livres.

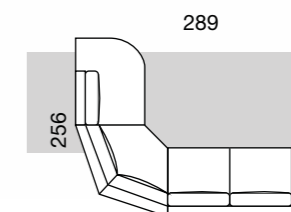

256

289

art. GD/GS + AT + PD/PS

special price

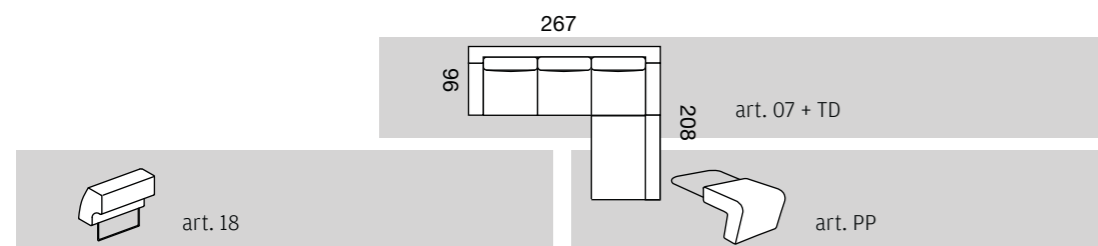
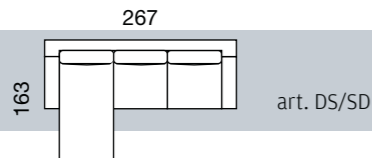

OPTIONAL: Cuscino schienale con supporto per elem. terminale
Back cushion with support for end element
Coussin dossier a/support pour elem. term.

OPTIONAL: Poggia piedi
Footrest
Repose-pieds

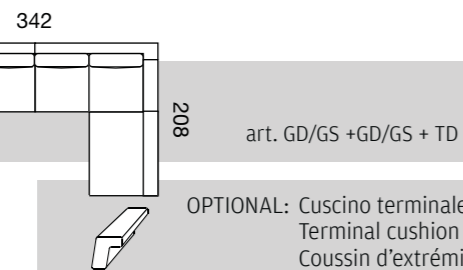

OPTIONAL: Cuscino terminale
Terminal cushion
Coussin d'extrémité art. 17



DISPONIBILI
ANCHE...
ALSO
AVAILABLE...
ÉGALEMENT
DISPONIBLE ...

Chaise longue con contenitore
Chaise longue with container
Chaise longue avec rangement



Terminale con contenitore
Terminal with container
Extrémité avec rangement



Scoprire è la capacità di lasciarsi disorientare dalle cose semplici.
Discovery is the ability to be puzzled by simple things.

Découvrir est la capacité de se laisser désorienter par des choses simples.

Noam Chomksy

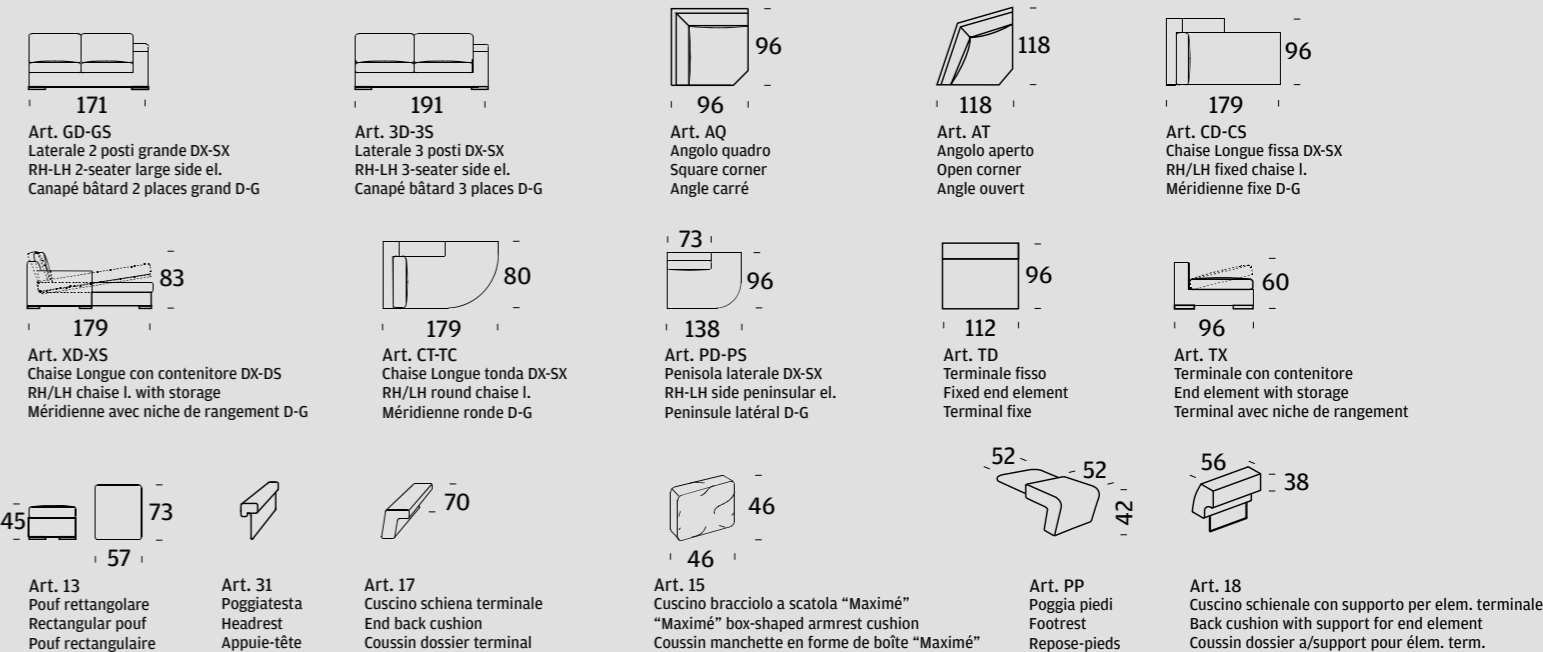
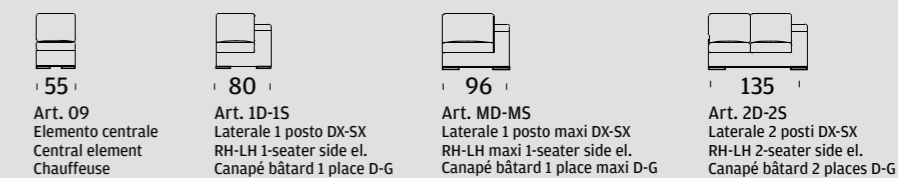
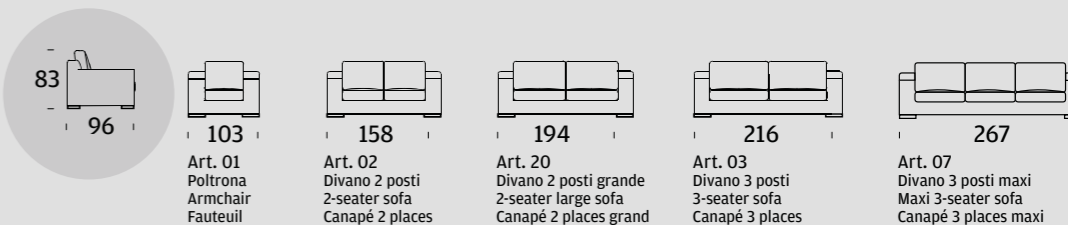

• LISTINO PREZZI / PRICE LIST / LISTE DES PRIX pag. 299

Struttura e molleggio

Struttura realizzata con masselli portanti in legno di pioppo o abete di vari spessori. Parti di tamponamento in fibra grezza e/o compensato. Fianchi in agglomerato di legno da 18 mm. Fibra grezza e agglomerato di legno appartengono alla classe E1, pertanto a bassa emissione di formaldeide, termocoppia ad espanso e/o ovatta di fibra poliestere 100% resinata.

Molleggio realizzato mediante nastri elastici da 80 mm tesi meccanicamente, composti da fili di gomma ricoperti da filo di nylon avvolto a spirale.

Imbottitura e piedi

Cuscino seduta in espanso indeformabile D30 e cuscino schienale in espanso D18, entrambi rivestiti con ovatta di fibra di poliestere da 300 g termolegata. Cuscino schienale per terminale in espanso D18 rivestito con resinato da 100 g/mq accoppiato da 3 mm e vellutino. Sagomati vari a completamento in espanso D25/40.

Piedi in legno finitura ciliegio, wengé e alluminio.

Structure and springs

Structure made with bearing parts in poplar or fir wood in various thicknesses. Reinforcing parts made of rough fibre and/ or plywood. Sides in 18 mm agglomerated wood chips. Rough fibre and the agglomerated wood chips are in class E1 thus with a low formaldehyde emission; thermocoupled to foam and/or 100% resinated polyester fibre wadding.

Spring made with elastic bands composed of mechanically tightened rubber threads covered with nylon thread, coiled up in a spiral, 80 mm thick.

Upholstery and feet

Seat cushion in D30 non deformable foam and backrest cushion in D18 foam - both covered with 300 g of thermobonded polyester fibre wadding. Backrest cushion for terminal in D18 foam, covered with 3 mm of coupled 100 g/m2 resinat and velveteen. Various shaped elements in foam to complete with a D25/40.

Wood foot with cherry, wengé and aluminium finishes.

Structure et suspension

Structure réalisée en panneaux massifs de peuplier ou de sapin de différentes épaisseurs. Éléments de remplissage en fibre brute et/ou en contreplaqué. Côtés en bois aggloméré de 18 mm. Fibre brute et bois aggloméré de classe E1, donc à basse émission de formaldéhyde, thermiquement associé à expansé et/ou à ouate 100% fibre de résine polyester.

Suspension réalisée à l'aide de sangles élastiques composées de fils de caoutchouc recouverts de fil de nylon enroulé en spirale de 80 mm tendues mécaniquement.

Rembourrage et pieds

Coussin d'assise en expansé indéformable de D30 et coussin de dossier en expansé de D18, tous deux revêtus d'ouate de fibre polyester de 300 g associée thermiquement. Coussin de dossier pour élément terminal en expansé de D18 revêtu de résine de 100 g/m2 associé à 3 mm et velours. Différents modèles en complément en expansé de D25/40.

Pied en bois en finition merisier, wengé et aluminium.

BLOOM style

Un buon divano è spesso ciò che c'è di più efficace per imbastire una conversazione.

There is nothing like a pair of matching sofas for sparking off a conversation.

Un bon canapé est souvent le moyen le plus efficace pour entamer une conversation.

Francis Bacon

COMFORT E SPAZIO

Sei in cerca di un sistema di sedute contemporaneo capace di spostarsi e cambiare in base ai tuoi gusti, alle tue necessità di comfort e spazio? Ecco il modello Bloom: una facile combinazione di comfort e flessibilità.

COMFORT AND SPACE

Are you looking for a contemporary seating system that can be moved and changed according to your taste, your needs for comfort, and space? Bloom is the model for you: an easy combination of comfort and flexibility.

CONFORT ET ESPACE

Vous cherchez un système d'assise contemporains capable de se déplacer et de changer selon vos goûts, vos besoins de confort et d'espace ?

Voici le modèle Bloom : une combinaison simple de confort et de flexibilité.



249

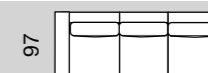

97

art. B5



CAMBIO FACILE

Bloom è il divano componibile dotato di un pouf agganciato frontalmente al divano che permette di ottenere una comoda chaise longue reversibile a destra e a sinistra, a proprio piacimento. Per cambiare in libertà.

EASY CHANGE

Bloom is the sectional sofa with an pouf hooked on the front that allows you to get a comfortable chaise longue, reversible on left and right, to your liking. So as to change freely.

CHANGEMENT FACILE

Bloom est le canapé modulaire doté d'un pouf accroché à l'avant du canapé, permettant d'obtenir une confortable chaise longue réversible à gauche et à droite, exactement comme vous le souhaitez. Pour des changements en toute liberté.

La chaise longue è reversibile a destra e a sinistra

The chaise longue is reversible on left and right

La chaise longue est réversible à droite et à gauche



SPAZIO AI DETTAGLI

A volte basta un pouf, un tappeto diverso, un quadro per ravvivare l'arredo del vostro living. La chiave è il contrasto. Mixa colori neutri con piccoli tocchi più accesi. Il tuo soggiorno si arricchirà di personalità.

SPACE FOR DETAILS

Sometimes, all you need is an pouf, a different rug, a picture, to liven up the decor of your living room. Contrast is the key. Mix neutral colours with few stronger touches. Your living-room will be enriched by your personality.

PLACE AUX DÉTAILS

Parfois, il suffit d'un pouf, d'un autre tapis, un cadre pour égayer le décor de votre salon. La clé est dans le contraste. Mélangez les tons neutres avec une touche de couleurs vives. Votre séjour aura une plus grande personnalité.

special price

249

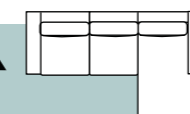

164

art. MB/BM

special price

230

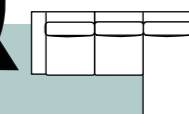

164

art. BC/CB





new!

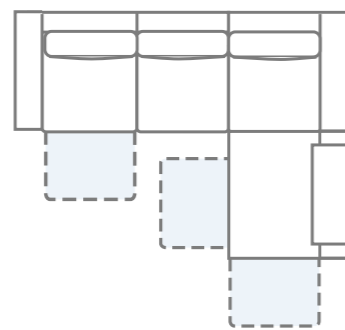

Poggia piedi
Footrest
Repose-pieds



UN DIVANO CHE NON STA MAI FERMO

Alle donne piace cambiare: spostare un mobile, aggiungere un quadro, cambiare il colore delle pareti... Perché non scegli un divano che cambia con te? Bloom è un divano che si basa sul principio modulare per garantirti la massima libertà di arredamento.

A SOFA THAT NEVER STAYS STILL

Women like changes: moving a piece of furniture, adding a picture, changing the colour of the walls... Why not choose a sofa that changes with you? Bloom is a sofa that is based on the modular principle to ensure maximum furnishing freedom.

UN CANAPÉ QUI NE RESTE JAMAIS EN PLACE

Les femmes aiment le changement : déplacer un meuble, ajouter un cadre, changer la couleur des murs ... Pourquoi ne pas choisir un canapé qui change avec vous ? Bloom est un canapé basé sur un principe modulaire permettant de garantir la plus grande liberté d'ameublement.

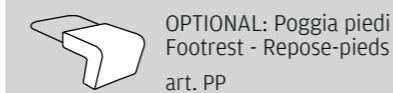
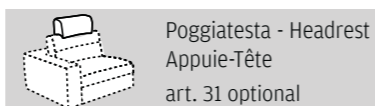
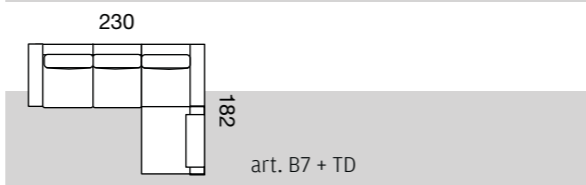
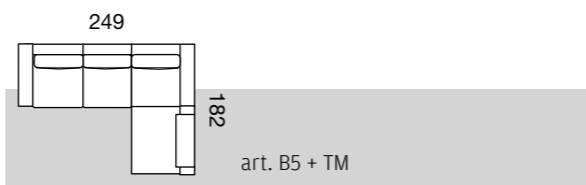

Art. 01
Poltrona
Armchair
Fauteuil



Art. 02
Divano 2 posti
2-seater sofa
Canapé 2 places



Art. 20
Divano 2 posti grande
2-seater large sofa
Canapé 2 places grand

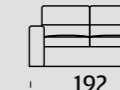

Art. 06
Divano 2 posti maxi
2-seater maxi sofa
Canapé 2 places maxi



Art. 03
Divano 3 posti
3-seater sofa
Canapé 3 places



Art. B7
Divano 3 posti
3-seater sofa
Canapé 3 places



Art. B5
Divano 3 posti
3-seater sofa
Canapé 3 places



Art. 1D-1S
Laterale 1 posto DX-SX
RH-LH 1-seater side el.
Canapé bâtarde 1 places D-G



Art. MD-MS
Laterale 1 posti maxi DX-SX
RH-LH 1-seater maxi side el.
Canapé bâtarde 1 places maxi D-G

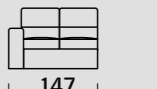

Art. 2D-2S
Laterale 2 posti DX-SX
RH-LH 2-seater side el.
Canapé bâtarde 2 places D-G

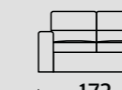

Art. GD-GS
Laterale 2 posti maxi DX-SX
RH-LH 2-seater maxi side el.
Canapé bâtarde 2 places maxi D-G

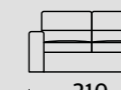

Art. 7D-7S
Laterale 3 posti big DX-SX
RH-LH 3-seater big side el.
Canapé bâtarde 3 places big D-G



Art. LQ-QL
Laterale angolo quadro
Square corner side el.
Canapé bâtarde angle rond



Art. AT
Angolo tondo
Round corner
Angle rond

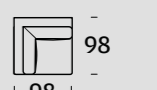

Art. AQ
Angolo quadro
Square corner
Angle carré



Art. TD
Terminale
End element
Terminal



Art. TM
Terminale maxi
Maxi end element
Terminal maxi

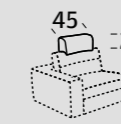

Art. 31
Poggiatesta
Headrest
Appuie-tête

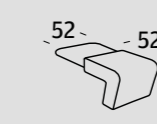

Art. PP
Poggia piedi
Footrest
Repose-pieds

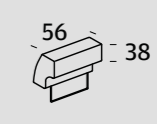

Art. 18
Cuscino schienale con supporto per elem. terminale
Back cushion with support for end element
Cousin dossier a/support pour elem. term.



Art. 17
Cuscino schiena terminale
End back cushion
cousin dossier terminal

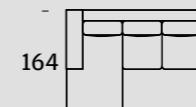

Art. CB-BC
Special con penisola reversibile
Special sofa with reversible chaise
Special canapé avec chaise longue réversible

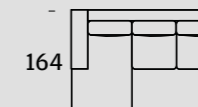

Art. BM-MB
Special con penisola maxi reversibile
Special maxi sofa with reversible chaise
Special canapé maxi avec chaise longue réversible

• LISTINO PREZZI / PRICE LIST / LISTE DES PRIX pag. 303

Espandi il comfort con l'elemento angolare.

Expand its comfort with the corner element.

Développez le confort avec l'élément d'angle.

Struttura e molleggio

Realizzata con masselli di legno di abete massiccio di vari spessori, parti di tamponamento in fibra grezza e/o compensato di pino; fianchi in agglomerato di legno a bassa emissione di formaldeide (appartenente alla classe E1), il tutto rivestito con vellutino 100% poliammide termoaccoppiato ad espanso e/o ovatta in fibra di poliestere 100%.
Molleggio realizzato con nastri elastici composti da fili di gomma ricoperti da filo di nylon avvolto a spirale da 80mm, tesi meccanicamente.

Imbottitura e piedi

Cuscino seduta in espanso indeformabile D30 rivestito in resinato di poliestere 100% da gr. 150.
Cuscino schienale e poggiatesta in espanso indeformabile D16 morbido rivestito in resinato 100% da gr. 150.
Bracciolo e parti di tamponamento in espanso indeformabile D30.
Piedi in ABS nero da 40mm.

Structure and springs

Solid fir of varying thickness; finishing components in raw fibre and/or poplar clipboard; sides in wood agglomerate (Class E1, low formaldehyde emission) covered with 100% polyamide thermally bound with polyurethane foam and/or 100% polyester fibre wadding. Elastic straps consisting of rubber threads covered with Nylon and wound into 80 mm coils, mechanically stretched.

Upholstery and feet

Seat cushion in non-deformable D30 polyurethane foam covered with 150 gr. 100% resin-coated polyester.
Back cushion and lower back cushion in non-deformable D16 soft polyurethane foam covered with 150 gr. 100% resin-coated polyester.
Armrests and finishing components in non-deformable D30 polyurethane foam.
Feet 40mm black ABS.

Structure et suspension

Réalisé avec du bois de sapin massif de différentes épaisseurs, des parties de tamponnage n fibre brute et/ou en compensé de peuplier; des côtés en aggloméré de bois à faible émission de formaldéhyde (appartenant à la classe E1), le tout revêtu avec du velours 100% polyamide thermo-accouplé à mousse et/ou ovate en fibre de polyester 100%.
Suspension réalisée avec des bandes élastiques composée de fils de caoutchouc recouverts de fil de nylon entouré en spirales de 80 mm, tendues mécaniquement.

Rembourrage et pieds



Coussin assise en mousse indéformable D30 revêtu en résine de polyester 100% de gr. 150.
Coussin dossier et repos-reins en mousse indéformable D16 souple revêtu en résine de polyester 100% de gr. 150.
Accoudoir et partie de tamponnage en mousse indéformable D30.
Pied en ABS noir de 40 mm.



NORMAN

style

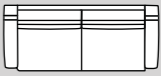
Qualsiasi opera di un uomo, si tratti di letteratura o musica o pittura o architettura, è sempre un suo ritratto.
Every man's work, whether it be literature or music or pictures or architecture or anything else, is always a portrait of himself.
Toute œuvre d'un homme, qu'il s'agisse de littérature, de musique, de peinture ou d'architecture, reflète toujours son propre portrait.
Samuel Butler

216		art. 03
98		art. 12
70		art. 13
96		
78		

ERGONOMIA PERFETTA

Norman è un divano che grazie al suo alto schienale ergonomico consente una distribuzione uniforme del peso del corpo, favorendo il relax e il rilassamento di tutti i muscoli.

PERFECT ERGONOMICS

Norman is a sofa that, due to its high ergonomic backrest, allows a uniform distribution of the weight of the body, aiding relaxation of all muscles.

ERGONOMIE PARFAITE

Norman est un canapé qui, en raison de son haut dossier ergonomique, permet une distribution uniforme du poids du corps, favorisant la détente et la relaxation de tous les muscles.



IL VERO COMFORT SI MISURA IN CENTIMETRI



Lo schienale alto 99 cm di Norman è perfetto per garantire l'allineamento del tratto cervicale e lombare, assecondando il corpo, con grandi benefici per la tua schiena.

TRUE COMFORT IS MEASURED IN INCHES

The 99 cm high backrest of Norman is perfect to ensure the alignment of the cervical and lumbar spine, supporting the body with great benefits for your back.

LE VRAI CONFORT SE MESURE EN CENTIMÈTRES

Le dossier haut de 99 cm de Norman est parfait pour garantir l'alignement des cervicales et des lombaires, en soutenant le corps avec de grands avantages pour votre dos.



SCHIENALE ALTO; IDEALE PER LA SCHIENA

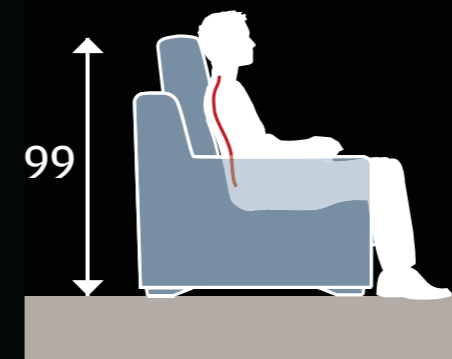

Sedile e schienale devono essere leggermente inclinati all'indietro, in modo che il peso del corpo si distribuisca uniformemente. La schiena dev'essere ben sostenuta a livello lombare, permettendo a tutta la muscolatura di rilassarsi.

HIGH BACKREST: IDEAL FOR THE BACK

Seat and backrest should be slightly tilted backwards, so that the body weight is evenly distributed. The backrest should be well supported at the lumbar level, allowing all the muscles to relax.

DOSSIER HAUT : L'IDÉAL POUR LE DOS

Assise et dossier doivent être légèrement inclinés vers l'arrière pour que le poids soit réparti uniformément. Le dossier doit être bien soutenu au niveau des lombaires, permettant à tous les muscles de se détendre.

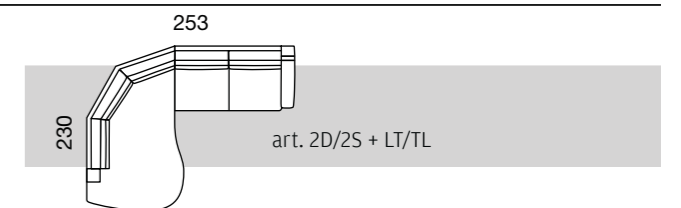



WARM MINIMALISM

Un'atmosfera minimalista e calda allo stesso tempo: è quella che sa regalare Norman, un divano confortevole e pratico, disponibile eventualmente anche con sacca esterna per custodire riviste e telecomandi.

A minimalist and warm feel at the same time: this is what Norman offers, a comfortable and practical sofa, which is also available with an external bag for storing magazines and remote controls.

Une ambiance minimaliste et chaleureuse à la fois : c'est que propose Norman, un canapé confortable et pratique, également disponible avec poche externe pour ranger magazines et télécommandes.

Molti mobili sono calchi del corpo umano.

Many pieces of furniture are casts of the human body.

De nombreux meubles sont calqués sur le corps humain. - Mario Praz



275

165

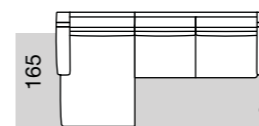

art. GD/GS + CM/MC

WENGÈ O CROMATO?

Dettagli che fanno la differenza. I piedini hanno una forma non comune che regala un fascino nuovo al sofà. Disponibili in acciaio o in legno wengè, si adattano perfettamente ad ogni ambiente.

WENGÈ OR CHROME?

Details making the difference. The feet have an uncommon shape that gives a new charm to the sofa. Available in steel or wengè wood, they fit perfectly into any environment.

WENGÉ OU CHROMÉ ?

Les détails qui font la différence. Les pieds ont une forme peu commune pour donner un charme nouveau au canapé. Disponibles en acier ou en bois de wengé, ils s'intègrent parfaitement dans n'importe quel espace.

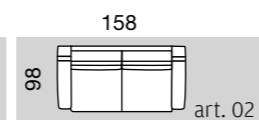
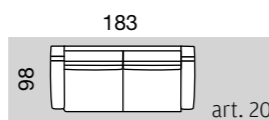

 99 98	 110 Art. 01 Poltrona Armchair Fauteuil	 158 Art. 02 Divano 2 posti 2-seater sofa Canapé 2 places	 183 Art. 20 Divano 2 posti grande 2-seater large sofa Canapé 2 places grand	 216 Art. 03 Divano 3 posti 3-seater sofa Canapé 3 places	 231 Art. 07 Divano 3 posti maxi Maxi 3-seater sofa Canapé 3 places maxi
 58 Art. 09 Elemento centrale Central element Chaufeuse	 77 Art. 91 Elemento centrale grande Big central element chauffeuse grand	 90 Art. 90 Elemento centrale maxi Maxi central element Chaufeuse maxi	 80 Art. 1D-1S Laterale 1 posto DX-SX RH-LH 1-seater side el. Canapé bâtarde 1 place D-G	 99 Art. MD-MS Laterale 1 posto maxi DX-SX RH-LH maxi 1-seater side el. Canapé bâtarde 1 place maxi D-G	 137 Art. 2D-2S Laterale 2 posti DX-SX RH-LH 2-seater side el. Canapé bâtarde 2 places D-G
 176 Art. GD-GS Laterale 2 posti grande DX-SX RH-LH 2-seater large side el. Canapé bâtarde 2 places grand D-G	 195 Art. 3D-3S Laterale 3 posti DX-SX RH-LH 3-seater side el. Canapé bâtarde 3 places D-G	 15 Art. 15 Sacca porta oggetti e copribrafcio amovibile Coating removable armrests Sac porte-objets et couvre-manchette amovibile	 32-23 Art. 32-23 Copribrafcio amovibile DX-SX RH-LH Pockets with coating removable armrests Couvre-manchette amovibile D-G		
 113 Art. AQ Angolo quadro Square corner Angle carré	 113 Art. AT Angolo tondo Round corner Angle rond	 80 Art. CD-CS Chaise longue reversibile DX-SX RH/LH reversible chaise l. Mériidienne réversible D-G	 99 Art. CM-MC Chaise longue reversibile Maxi DX-SX RH/LH reversible maxi chaise l. Mériidienne maxi réversible D-G		
 230 Art. LT-TL Laterale Angolo DX-SX RH-LH corner side el. Canapé bâtarde angle D-G	 43 78 Art. 13 Pouf rettangolare Rectangular pouf Pouf rectangulaire	 43 96 Art. 12 Pouf rettangolare maxi Rectangular pouf Pouf rectangulaire maxi			

La chaise longue è posizionale a piacimento a destra o a sinistra

The chaise longue can be positioned on the left or right, at will.

La chaise longue peut être positionnée au choix à droite ou à gauche.

• LISTINO PREZZI / PRICE LIST / LISTE DES PRIX pag. 306

Struttura e molleggio

Struttura realizzata con masselli portanti in legno di pioppo o abete di vari spessori. Parti di tamponamento in fibra grezza o compensato di pioppo. Fianchi in agglomerato da 18 mm in classe E1 a bassa emissione di formaldeide. Il tutto rivestito con vellutino 100% poliammide termoaccoppiato ad espanso. Molleggio realizzato mediante nastri elastici da 80 mm tesi meccanicamente, composti da fili di gomma ricoperti da filo di nylon avvolto a spirale.

Imbottitura e piedi

Cuscino seduta realizzato in espanso indeformabile D30, rivestito in falda di poliestere 100%, termo-fissato da 300 g. Cuscino schienale in espanso indeformabile D18. Bracciolo in espanso indeformabile D30 rivestito in vellutino accoppiato a resinato 200 g di poliestere. Piedino in legno color wengè oppure acciaio, finitura cromo lucido.

Cordonatura cuscini schienale

Cordone da 3,2 mm coperto di tessuto.

Structure and springs

Structure made with bearing parts in poplar or fir wood in various thicknesses. Reinforcing parts made of rough fibre or poplar plywood. Sides made of 18mm thick agglomerated chips with low formaldehyde emission class E1. The whole is covered with 100% polyamide velveteen thermocoupled to foam. Spring made of mechanically tightened 80 mm thick elastic bands, comprising rubber threads covered with nylon thread, coiled up in a spiral.

Upholstery and feet

Seat cushion in D30 non deformable foam, covered with a thermofixed 100% polyester lap. Backrest cushion in D18 non deformable foam. Armrest in D30 non deformable foam covered with velveteen coupled with 200 g of resinated polyester. Foot in wengè wood colour or with a steel bright chrome finish.

Backrest cushion cording

3.2 mm cording covered with fabric.

Structure et suspension

Structure réalisée en panneaux massifs de peuplier ou de sapin de différentes épaisseurs. Éléments de remplissage en fibre brute et/ou en contreplaqué de peuplier. Côtés en bois aggloméré de 18 mm de classe E1 à basse émission de formaldéhyde. Le tout est revêtu de velours 100% polyamide thermiquement associé à expansé. Suspension réalisée à l'aide de sangles élastiques de 80 mm tendues mécaniquement, composées de fils de caoutchouc recouverts de fil de nylon enroulé en spirale.

Rembourrage et pieds

Coussin d'assise en expansé indeformable de D30, revêtu de voile 100% polyester de 300 g fixé thermiquement. Coussin de dossier en expansé indeformable de D18. Accoudoir en expansé indeformable de D30, revêtu de velours associé à résine polyester de 200 g. Pied en bois couleur wengè ou en finition acier, chrome brillant.

Nervure des coussins de dossier

Cordon de 3,2 mm recouvert de tissu.

PAPRIKA

style

I colori sono i veri abitanti dello spazio.
Colours are the true inhabitants of space.
Les couleurs sont les véritables habitants de l'espace. - I. Klein

SAGOMATO SUL CORPO

Morbidi braccioli, confortevoli per le braccia ma anche per la testa quando ci si distende. Paprika è un modello sagomato sul corpo umano.

SHAPED ON OUR BODY

Soft armrests, comfortable for your arms but also for your head when you lay down. Paprika is a model shaped on the human body.

FAÇONNAGE DES FORMES

Accoudoirs moelleux, confortables pour les bras mais également pour la tête en position allongée. Paprika est un modèle façonné à partir du corps humain.

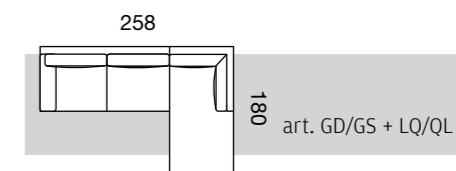

ERGONOMIA! PRIMA DI TUTTO

Architettura è organizzazione.

Architecture is organization.

Architecture est organisation. - Le Corbusier

Paprika è un modello sagomato sul corpo umano, studiato per essere ergonomicamente perfetto.

ERGONOMICS! FIRST OF ALL

Paprika is a model shaped on the human body, designed to be ergonomically perfect.

ERGONOMIE! AVANT TOUT

Paprika est un modèle façonné à partir du corps humain, conçu pour une ergonomie parfaite.

Tra l'ampia gamma di tappeti, trova quello più adatto al tuo stile di arredamento.

Among the wide range of carpets, find the one that better suits your style of decor.

Parmi la vaste gamme de tapis, trouvez celui le plus adapté à votre style.



210



art. 03



OTTIMIZZA LO SPAZIO

Il divano ad angolo è l'ideale per chi ha la necessità di ottimizzare gli spazi: a parità di posti a sedere, è meno ingombrante rispetto ad un divano sviluppato in lunghezza e consente di organizzare l'arredo in maniera funzionale.

OPTIMIZE THE SPACE

The corner sofa is ideal for those who need to optimize the space: with the same number of seats, it is less bulky than a sofa developed in length and it allows you to arrange the furniture in a functional manner.

OPTIMISEZ L'ESPACE

Le canapé d'angle est idéal pour optimiser l'espace : pour un même nombre de places assises, il est moins encombrant qu'un canapé tout en longueur et permet d'organiser l'ameublement de façon fonctionnelle.



Art. 01
Poltrona
Armchair
Fauteuil

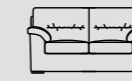

Art. 02
Divano 2 posti
2-seater sofa
Canapé 2 places

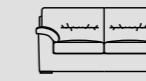

Art. 20
Divano 2 posti maxi
2-seater maxi sofa
Canapé 2 places maxi

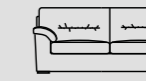

Art. 03
Divano 3 posti
3-seater sofa
Canapé 3 places



Art. 09
Elemento centrale
Central element
Chauffeuse



Art. 90
Elemento centrale maxi
Maxi central element
Chauffeuse maxi



Art. 1D-1S
Laterale 1 posto DX-SX
RH-LH 1-seater side el.
Canapé bâtarde 1 place D-G



Art. MD-MS
Laterale 2 posti maxi DX-SX
RH-LH maxi 1-seater side el.
Canapé bâtarde 1 place maxi D-G



Art. 2D-2S
Laterale 2 posti DX-SX
RH-LH 2-seater side el.
Canapé bâtarde 2 places D-G



Art. GD-GS
Laterale 2 posti grande DX-SX
RH-LH 2-seater large side el.
Canapé bâtarde 2 places grand D-G

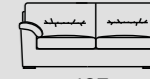

Art. 3D-3S
Laterale 3 posti DX-SX
RH-LH 3-seater side el.
Canapé bâtarde 3 places D-G

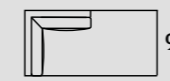

Art. LQ-QL
Laterale angolo quadro
Square corner side el.
Canapé bâtarde angle carré



Art. LT-TL
Laterale angolo DX-SX
RH-LH corner side el.
Lateral d'angle D-G

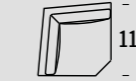

Art. AT
Angolo aperto
Open corner
Angle ouvert

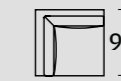

Art. AQ
Angolo quadro
Square corner
Angle carré

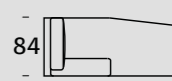

Art. CD-CS
Chaise longue DX-SX
RH/LH chaise L.
Méristienne D-G

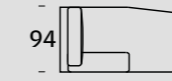

Art. CM-MC
Chaise longue maxi DX-SX
RH/LH maxi chaise L.
Méristienne maxi D-G

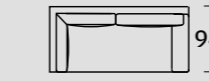

Art. TD-TS
Terminale angolo DX-SX
RH-LH end corner el.
Terminal angle D-G



Art. TM-MT
Terminale angolo maxi DX-SX
RH-LH maxi end corner el.
Terminal angle maxi D-G



Art. 13
Pouf rettangolare
Rectangular ottoman
Pouf rectangulaire

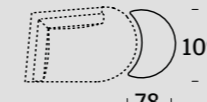

Art. PA
Pouf anteriore
Front ottoman
Pouf avant

• LISTINO PREZZI / PRICE LIST / LISTE DES PRIX pag. 309

Struttura e molleggio

Struttura realizzata con masselli portanti in legno di pino o abete di vari spessori. Parti di tamponamento in fibra grezza e/o compensato. Fianchi in agglomerato di legno da 18 mm. Realizzato con particelle di legno a bassa emissione di formaldeide, appartenenti alla classe E1 ai sensi delle norme UNI EN 312-1 e UNI EN 120. Il tutto rivestito con vellutino 100% poliammide termoaccoppiato ad espanso e/o ovatta in fibra di poliestere 100% resinata. Molleggio realizzato con nastri elastici da 80 mm tesi meccanicamente, composti da fili di gomma ricoperti da filo di nylon avvolto a spirale.

Imbottitura e piedi

Cuscino seduta in espanso indeformabile D30. Cuscino schienale in espanso indeformabile D18. Cuscino bracciolo espanso indeformabile D25. Sedute, schienali e cuscini bracciolo sono rivestiti con ovatta di fibra di poliestere da 300 g termolegata. Piedi in legno tinto wengé con profilo in metallo.

Structure and springs

Structure made with bearing parts in poplar or fir wood in various thicknesses. Reinforcing parts made of rough fibre and/or plywood. Sides made of 18 mm thick agglomerated wood chips. Made with wood particles with a low formaldehyde emission (Class E1) in compliance with the UNI EN 312-1 and UNI EN 120 norms. The whole is covered in 100% polyamide velveteen thermocoupled to foam and/or 100% resinated polyester fibre wadding. Spring made of mechanically tightened 80 mm thick elastic bands, composed of rubber threads covered with nylon thread, coiled up in a spiral.

Upholstery and feet

Seat cushion in D30 non deformable foam. Backrest cushion in D18 non deformable foam. Armrest cushion in D25 non deformable foam. Seat, backrest and armrest cushions are covered with 300 g thermobonded polyester fibre wadding. Feet in wengé stained wood with metal profile. Wood foot with cherry, wengé or aluminium finish.

Structure et suspension

Structure réalisée en panneaux massifs de peuplier ou de sapin de différentes épaisseurs. Éléments de remplissage en fibre brute et/ou en contreplaqué. Côtés en bois aggloméré de 18 mm. Réalisé en particules de bois à basse émission de formaldéhyde, appartenant à la classe E1 au sens des normes UNI EN 312-1 et UNI EN 120. Le tout est revêtu de velours 100% polyamide thermiquement associé à expansé et/ou à ouate 100% fibre de résine polyester. Suspension réalisée à l'aide de sangles élastiques de 80 mm tendues mécaniquement, composées de fils de caoutchouc recouverts de fil de nylon enroulé en spirale.

Rembourrage et pieds

Coussin d'assise en expansé indéformable de D30. Coussin de dossier en expansé indéformable de D18. Coussin accoudoir en expansé indéformable de D25. Assises, dossiers et coussins accoudoirs sont revêtus d'ouate de fibre polyester de 300 g thermiquement associée. Pieds en bois teinté wengé avec profil en métal.

NIKKO

style

UN CLASSICO MODERNO

Semplice, pulito: Nikko è la sintesi perfetta fra moderno e classico. Per abitare con coerenza il tempo attuale e la memoria. Perfetto sia in ambientazioni iper-moderne sia in contesti più tradizionali.

A MODERN CLASSIC

Simple, clean: Nikko is the perfect synthesis between modern and classic. To live the current times and memory with coherence. Perfect for both hyper-modern environments and more traditional contexts.

UN CLASSIQUE MODERNE

Simple, propre : Nikko est la synthèse parfaite entre moderne et classique. Pour vivre avec cohérence l'actuel et la mémoire. Parfait pour les ambiances hyper modernes ou dans des contextes plus traditionnels.

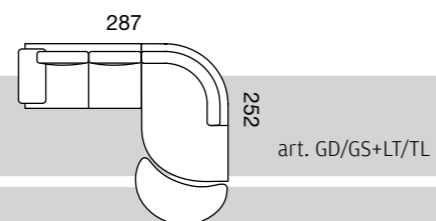

Pouf anteriore - Front pouf - Pouf avant



Il bianco è il colore sfacciato del pudore.

White is the shameless colour of modesty.

Le blanc est la couleur effrontée de la pudeur. - Tommaso Landolfi

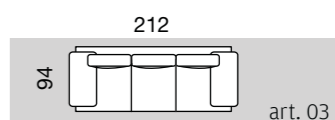

La bellezza è la migliore lettera di raccomandazione.

Beauty is the best letter of recommendation.

La beauté est la meilleure lettre de recommandation. - Aristotele

DIVANO ANGOLARE



CORNER SOFA

Il divano angolare Nikko ti permette di sfruttare gli angoli, seguendo perfettamente il tuo stile e offrendoti tutto il comfort di cui hai bisogno. Così hai tanti posti a sedere extra.

The Nikko corner sofa allows you to take advantage of the corners, perfectly following your style and offering all the comfort you need. So you can have many extra seats.

CANAPÉ D'ANGLE

Le canapé d'angle Nikko permet d'exploiter chaque recoin, tout en respectant parfaitement votre style et en offrant tout le confort dont vous avez besoin. Ainsi, vous disposez de places assises supplémentaires.

287

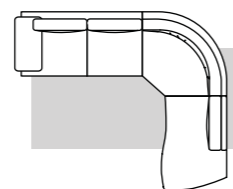

art. GD/GS+AT+ TD/TS



UN DIVANO OVERSIZE

Nikko, proposto nella versione con sedute XL, è la soluzione ideale per chi desidera un salotto moderno. Progettato secondo i più recenti canoni dell'ergonomia. Le sue ampie e morbide sedute sono estremamente confortevoli, studiate per garantire il relax ottimale.

AN OVERSIZE SOFA

Nikko, proposed in the version with XL seats, is the ideal solution for those who want a modern living room. Designed according to the latest standards of ergonomics. Its large, soft seats, are extremely comfortable, designed to ensure optimum relaxation.



UN CANAPÉ OVERSIZE

Nikko, proposé dans sa version avec assises XL, est la solution idéale pour qui souhaite un salon moderne. Conçu selon les dernières tendances de l'ergonomie. L'assise vaste et moelleuse est extrêmement confortable et conçue pour assurer une détente optimale.

179



art. 20

DIVERSE FORME

Un terminale rotondo. Un altro a penisola retta. Un altro a penisola sinuosa. Nikko le ha pensate tutte per venire incontro ad ogni tuo desiderio. Anche i piedi sono disponibili nelle finiture ciliegio, wengè e alluminio. A te la scelta.

DIFFERENT SHAPES

A round terminal. Another one with a straight peninsula. Another one with a curved peninsula. Nikko has thought of everything to cater to your every wish. Feet are available in cherry, wengè and aluminium finishes. The choice is yours.

DIVERSITÉ DES FORMES

Une extrémité arrondie. Une autre en péninsule linéaire. Une autre en péninsule sinueuse. Nikko a pensé à tout pour répondre à vos moindres désirs. Les pieds sont également disponibles en finitions merisier, wengè et aluminium. C'est vous qui décidez.



SCEGLI IL PIEDINO

CHOOSE THE FOOT
CHOISISSEZ LE PIED

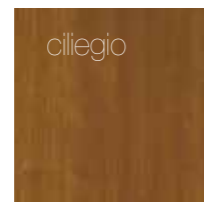

ciliegio

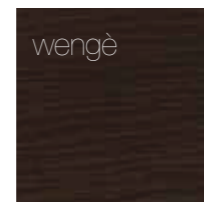

wengè



alluminio

Piede disponibile nelle finiture ciliegio, wengè e alluminio.
Foot available in cherry, wengè and aluminium finishes.
Pied disponible en finitions merisier, wengè et aluminium.

88
94

106

Art. 01
Poltrona
Armchair
Fauteuil



154

Art. 02
Divano 2 posti
2-seater sofa
Canapé 2 places



179

Art. 20
Divano 2 posti grande
2-seater large sofa
Canapé 2 places grand



212

Art. 03
Divano 3 posti
3-seater sofa
Canapé 3 places



58

Art. 09
Elemento centrale
Central element
Chausseuse



90

Art. 90
Elemento centrale maxi
Maxi central element
Chausseuse maxi



78

Art. 1D-1S
Laterale 1 posto DX-SX
RH-LH 1-seater side el.
Canapé bâtard 1 place D-G



97

Art. MD-MS
Laterale 1 posto maxi DX-SX
RH-LH maxi 1-seater side el.
Canapé bâtard 1 place maxi D-G



135

Art. 2D-2S
Laterale 2 posti DX-SX
RH-LH 2-seater side el.
Canapé bâtard 2 places D-G



174

Art. GD-GS
Laterale 2 posti grande DX-SX
RH-LH 2-seater large side el.
Canapé bâtard 2 places grand D-G

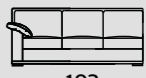

193

Art. 3D-3S
Laterale 3 posti DX-SX
RH-LH 3-seater side el.
Canapé bâtard 3 places D-G



113

Art. AT
Angolo tondo
Round corner
Angle rond

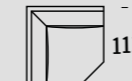

113

Art. AQ
Angolo quadro
Square corner
Angle carré



160

Art. CD-CS
Chaise longue reversibile DX-SX
RH/LH reversible chaise l.
Mérienne réversible D-G



160

Art. CM-MC
Chaise longue reversibile Maxi DX-SX
RH/LH reversible maxi chaise l.
Mérienne maxi réversible D-G



200

Art. LT-TL
Laterale angolo tondo DX-SX
RH-LH round corner side el.
Canapé bâtard angle rond D-G



193

Art. LQ-QL
Laterale angolo quadro DX-SX
RH-LH square corner side el.
Canapé bâtard angle carré D-G

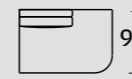

135

Art. TO-OT
Terminale tondo DX-SX
RH-LH round end el.
Terminal rond D-G



138

Art. TD-TS
Terminale DX-SX
RH-LH end el.
Terminal D-G



115

Art. PA
Pouf penisola anteriore
Pouf for front peninsular el.
Pouf péninsule avant



43

Art. 13
Pouf rettangolare
Rectangular pouf
Pouf rectangulaire



43

Art. 14
Pouf rettangolare maxi
Maxi rectangular pouf
Pouf rectangulaire maxi

Schienale alto, comfort perfetto.

High backrest, maximum comfort.

Dossier haut, confort parfait.

• LISTINO PREZZI / PRICE LIST / LISTE DES PRIX pag. 312

Struttura e molleggio

La struttura è realizzata con masselli portanti in legno di pioppo o abete di vari spessori. Parti di tamponamento in fibra grezza e/o compensato. Fianchi in agglomerato di legno da 18 mm. Fibra grezza e agglomerato di legno appartengono alla classe E1, pertanto sono a bassa emissione di formaldeide. Il tutto è rivestito in vellutino 100% poliammide termoaccoppiato ad espanso e/o ovatta in fibra poliestere 100% resinata. Molleggio realizzato con nastri elastici da 80 mm tesi meccanicamente, composti da fili di gomma ricoperti da filo di nylon avvolto a spirale.

Imbottitura e piedi

Cuscino seduta in espanso indeformabile D30 e cuscino schienale in espanso D18, entrambi rivestiti con ovatta di fibra poliestere da 300 g termolegata. Cuscino bracciolo in espanso D18 rivestito da ovatta di fibra poliestere da 200 g resinata e da 300 g termolegata. Sagomati vari a completamento in espanso D40. Piedi in legno finitura ciliegio, wengè e alluminio.

Structure and springs

Structure made with bearing parts in poplar or fir wood in various thicknesses. Reinforcing parts in rough fibre and/ or plywood. Sides made of 18 mm thick agglomerated wood chips. Rough fibre and agglomerated chips in the E1 class, therefore with a low formaldehyde emission. The whole is covered in 100% polyamide velvetten thermocoupled to foam and/or 100% resin polyester fibre wadding. Spring made of mechanically tightened 80 mm thick elastic bands, composed of rubber threads covered with nylon thread, coiled up in a spiral.

Upholstery and feet

Seat cushion in D30 indeformable foam and backrest cushion in D18 foam - both covered with 300 g thermobond polyester fibre wadding. Armrest cushion in foam with D18, covered in polyester fibre wadding: resinata (200 g) or thermobond (300 g). Various shaped completing elements, made of foam, with D40. Wood foot with cherry, wengè and aluminium finishes.

Structure et suspension

La structure est réalisée en panneaux massifs de peuplier ou de sapin de différentes épaisseurs. Parties de fileurs en fibre brute et/ou contreplaqué. Côtés en bois aggloméré de 18 mm. La fibre brute et le bois aggloméré appartiennent à la classe E1 et donc ils sont à basse émission de formaldéhyde. Le tout est revêtu de velours 100% polyamide associé thermiquement à l'expansé et/ou à la ouate en fibres de polyester 100% résine. Suspension réalisée à l'aide de sangles élastiques de 80 mm tendues mécaniquement, composées de fils de caoutchouc recouverts de fil de nylon enroulé en spirale.

Rembourrage et pieds

Coussin d'assise en expansé indéformable de D30 et coussin de dossier en expansé de D18, tous deux revêtus de ouate de fibre polyester de 300 g associée thermiquement. Coussin du dossier en expansé D18 revêtu de ouate de fibre polyester de 200 g en résine et de 300 g associée thermiquement. Différents modèles en complément en expansé de D40. Pieds en bois en finition merisier, wengè et aluminium.

MODÌ style

L'architettura si abita mentre l'arte si guarda.

Architecture is lived, while art is looked at.

L'architecture est faite pour être habitée tandis que l'art est fait pour être regardé. - Ettore Sottsass

IL LINGUAGGIO DELL'INTIMITÀ

Modì è un divano che risponde al desiderio di morbidezza e informalità. Parla un linguaggio contemporaneo, dove i dettagli fanno la differenza. Come la sua profondità ridotta che lo rende adatto ai nuovi modi di abitare d'oggi. Adatto a spazi domestici contenuti.

THE LANGUAGE OF INTIMACY

Modì is a sofa that responds to the desire of softness and informality. It speaks a contemporary language, where details make the difference. Like its reduced depth, that makes it suitable for the new ways of living of today. Suitable for small domestic spaces.

LE LANGAGE DE L'INTIMITÉ

Modì est un canapé qui répond au désir de douceur et de décontraction. Il parle une langue contemporaine, où les détails font la différence. Tout comme sa profondeur réduite qui en fait un canapé adapté à la nouvelle façon de vivre d'aujourd'hui. Il convient aux espaces domestiques de dimensions réduites.



Le forme geometriche di Modì si accentuano con la penisola retta, anche questa posizionabile a piacere.

Modì's geometrical shapes are accentuated with the straight peninsula which can go where you want it.

Les formes géométriques de Modì sont accentuées par la méridienne linéaire qui se place elle aussi où l'on veut.

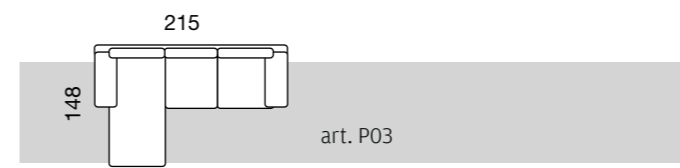

IL DIVANO COME VUOI TU

Modì è un divano profondo soli 82 cm, quindi è la soluzione ideale per ottimizzare gli spazi del tuo soggiorno. La sua penisola può essere posizionata a destra, a sinistra o al centro, indifferentemente.



THE SOFA AS YOU WANT IT

Modì is an only 82 cm deep sofa, so it is the ideal solution to optimize space in your living-room. Its peninsula can be positioned to the right, left or centre, at will.



LE CANAPÉ COMME VOUS LE SOUHAITEZ

Modì est un canapé de seulement 82 cm de profondeur, il est donc la solution idéale pour optimiser l'espace de votre séjour. Sa péninsule peut être positionnée à droite, à gauche ou au centre, indifféremment.



Ogni materiale ha solo il valore che da esso sappiamo trarre.

Each material is only what we make it.

La matière a uniquement la valeur que nous réussissons à lui donner. - M. V. Der Roohe

CAMBIA LOOK



Pochi accessori possono cambiare l'aspetto di una stanza. Nuovi cuscini, una lampada vintage o una mensola di design rinnoveranno la zona living.



CHANGE LOOK

Few accessories can change the look of a room. New pillows, a vintage lamp or a designer shelf can renew the living area.

CHANGEZ DE LOOK

Pochi accessori possono cambiare l'aspetto di una stanza. Nuovi cuscini, una lampada vintage o una mensola di design rinnoveranno la zona living.

Vai a pag. 245 per guardare l'intera collezione di cuscini - Go to p. 245 to look at the entire collection of cushions. - Rendez-vous page 245 pour découvrir la collection de coussins



LA SEDUTA IDEALE

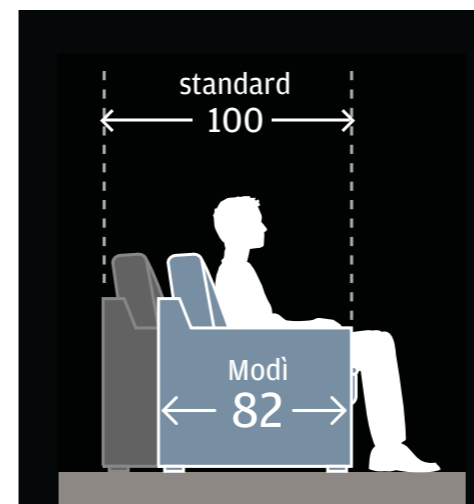

Gli studi ergonomici sostengono la profondità ridotta di 82 cm: consente di appoggiare bene i piedi a terra ed essere più comodi quando ci si alza, senza far troppo sforzo sulla schiena. Senza dimenticare che è perfetta per ottimizzare gli spazi, magari ristretti, del tuo soggiorno.

THE IDEAL SEAT

Studies on ergonomics support a reduced depth of 82 cm: you can put your feet firmly on the ground and be more comfortable when you get up, without too much strain on your back. Not to mention that this is perfect for optimizing the space, even small, in your living-room.

L'ASSISE IDÉALE

Les études ergonomiques soutiennent l'usage de la profondeur réduite de 82 cm: elle permet de mettre correctement les pieds par terre et à se lever plus facilement, sans solliciter le dos de façon excessive. Sans oublier qu'elle est également parfaite pour optimiser l'espace, éventuellement limité de votre salon.

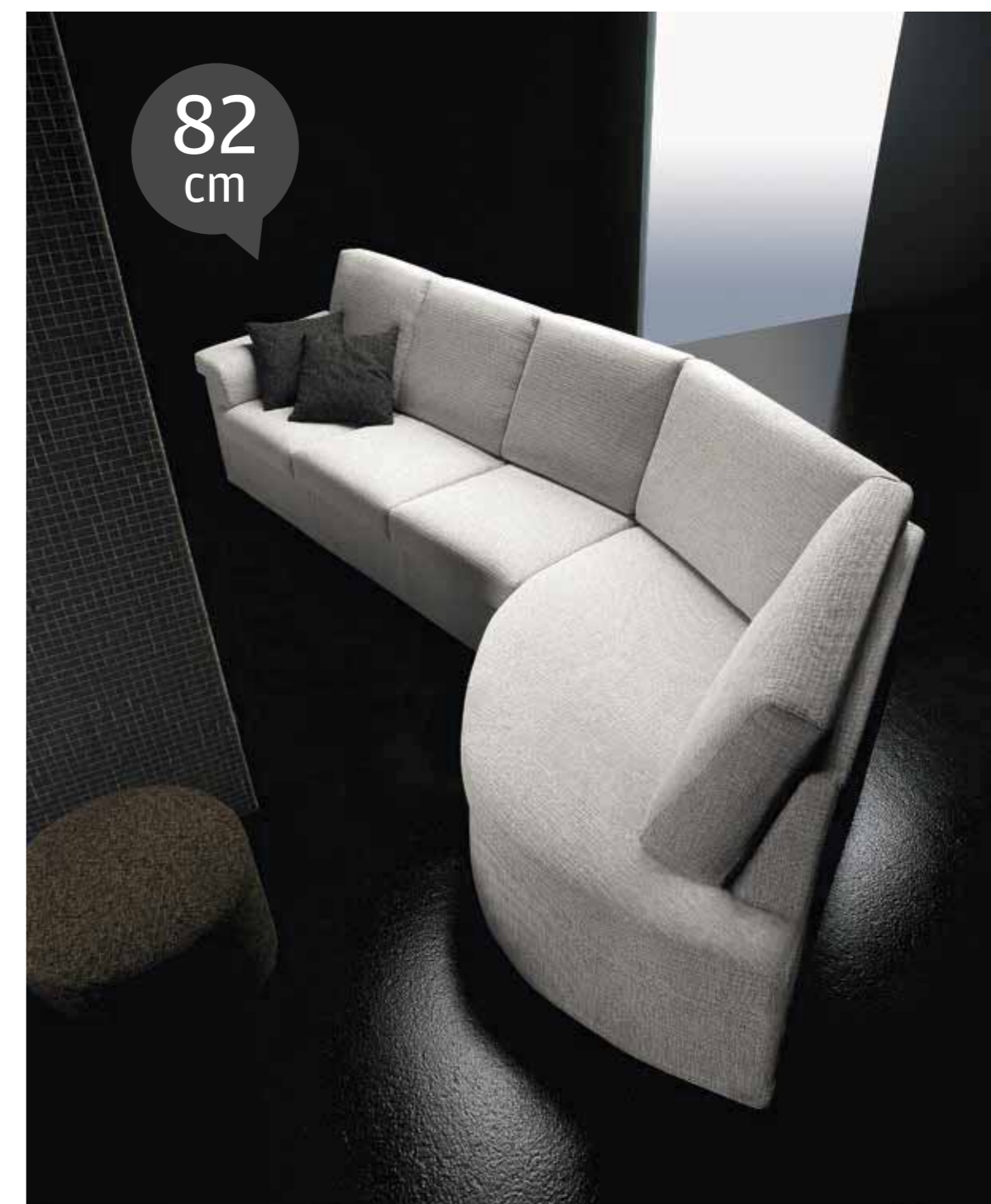

303

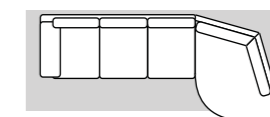

130

art. 3D/3S + LT/TL

LA FORZA DEL GRIGIO



Nell'arredamento, così come nella moda, il grigio è un colore di grande utilità. Rappresenta infatti una base perfetta facilmente accostabile ad ogni stile. Se abbinato a tutte le sue gradazioni risulta molto sofisticato e moderno.

THE POWER OF GREY

When it comes to interior decoration and fashion, grey is a colour of great use. It represents a perfect base, which easily matches every style. When combined with all its shades, it looks very sophisticated and modern.

LA FORCE DU GRIS

Dans l'ameublement comme dans la mode, le gris est une couleur extrêmement utile. Elle représente en effet une base parfaite pour un mariage facile avec tous les styles. Si elle est combinée dans toutes ses nuances, elle devient très sophistiquée et moderne.

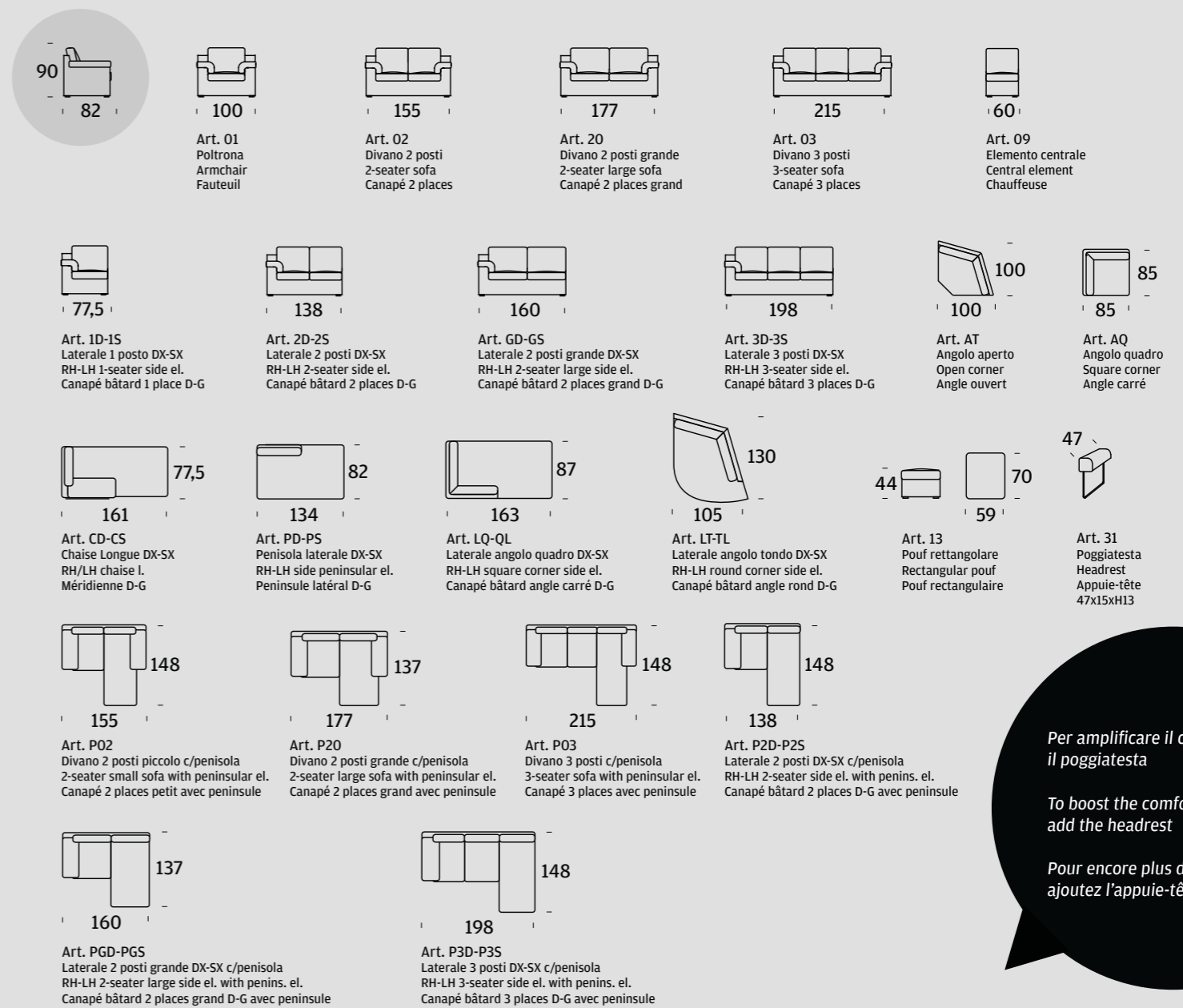

Per amplificare il comfort aggiungi il poggiatesta

To boost the comfort, you can add the headrest

Pour encore plus de confort, ajoutez l'appuie-tête

• LISTINO PREZZI / PRICE LIST / LISTE DES PRIX pag. 315

Struttura e molleggio

Struttura realizzata con masselli portanti in legno di pino o abete di vari spessori. Parti di tamponamento in fibra grezza e/o compensato. Fianchi in agglomerato di legno da 18 mm. Fibra grezza e agglomerato di legno appartengono alla classe E1, pertanto a bassa emissione di formaldeide. Il tutto rivestito con vellutino 100% poliammide termoaccoppiato ad espanso e/o ovatta di fibra poliestere 100% resinata. Molleggio realizzato con nastri elastici da 80 mm tesi meccanicamente, composti da fili di gomma ricoperti da filo di nylon avvolto a spirale.

Imbottitura

Cuscino seduta in espanso indeformabile D30 e cuscino schienale in espanso D18 indeformabile, entrambi rivestiti con ovatta di fibra di poliestere da 300 g termolegata. Bracciolo in espanso indeformabile D35. Sagomati vari a completamento in espanso D18/21.

Structure and springs

Structure made with bearing parts in poplar or fir wood in various thicknesses. Reinforcing parts made of rough fibre and/or plywood. Sides made of 16 mm thick agglomerated wood chips. Rough fibre and agglomerated wood chips, Class E1 and thus with low formaldehyde emissions. The whole is covered in 100% polyamide velvetene thermocoupled to foam and/or 100% resinated polyester fibre wadding. Spring made of mechanically tightened 80 mm thick elastic bands, composed of rubber threads covered with nylon thread, coiled up in a spiral.

Upholstery

Seat cushion in D30 non deformable foam and backrest cushion in D18 foam - both covered with 300 g of thermobonded polyester fibre wadding. Armrest cushion in D35 non deformable foam. Various shaped elements in foam to complete with an D18/21.

Structure et suspension

Structure réalisée en panneaux massifs de peuplier ou de sapin de différentes épaisseurs. Éléments de remplissage en fibre brute et/ou en contreplaqué. Côtés en bois aggloméré de 16 mm. Fibre brute et bois aggloméré de classe E1, donc à basse émission de formaldéhyde. Le tout est revêtu de velours 100% polyamide thermiquement associé à expansé et/ou à ouate 100% fibre de résine polyester. Suspension réalisée à l'aide de sangles élastiques de 80 mm tendues mécaniquement, composées de fils de caoutchouc recouverts de fil de nylon enroulé en spirale.

Rembourrage

Coussin d'assise en expansé indéformable de D30 et coussin de dossier en expansé de D18, tous deux revêtus d'ouate de fibre polyester de 300 g associée thermiquement. Accoudoir en expansé indéformable de D35. Différents modèles en complément en expansé de D18/21.

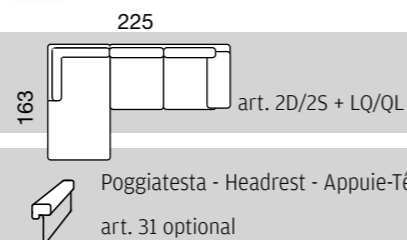

EXTÈ

style

SEMPLICE NATURALITÀ

Semplicità e naturalezza delle forme per Extè. Con la sua profondità ridotta di soli 82 cm e la componibilità delle sedute, questo sistema permette che ogni tuo desiderio diventi una realtà fatta di comfort e morbidezza.

NATURALLY SIMPLE

Simple and natural shapes for Extè. With its reduced depth of a mere 82 cm and the modularity of its seats, this system allows your every wish to become a reality made of comfort and softness.

SIMPLEMENT NATUREL

La simplicità et le naturel des formes pour le modèle Extè. Avec sa profondeur réduite de seulement 82 cm et la modularité de son assise, ce système permet de donner vie à tous vos désirs de confort et de douceur.

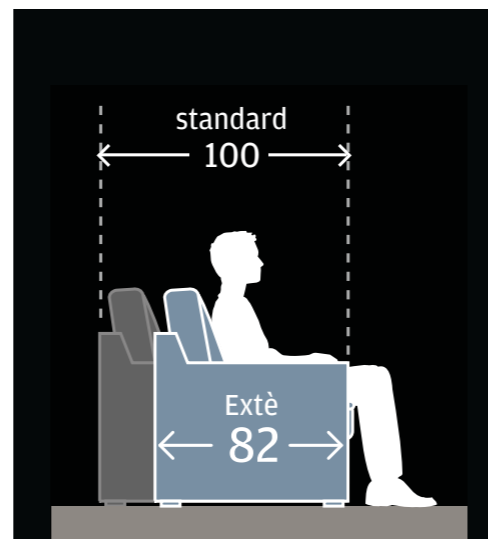

LA GIUSTA PROFONDITÀ

Non solo la profondità di 82 cm di Extè è perfetta per arredare spazi ristretti ma addirittura favorisce l'allineamento del tratto cervicale e lombare, assecondando il corpo. Con grandi benefici per la tua schiena.

THE RIGHT DEPTH

Not only the depth of 82 cm of Extè is perfect for decorating small spaces, but it also facilitates the alignment of the cervical and lumbar spine, supporting the body. With great benefits for your back.

LA BONNE PROFONDEUR

Non seulement la profondeur de 82 cm du modèle Extè est parfaite pour meubler les petits espaces, mais facilite également l'alignement de la colonne vertébrale et des lombaires, pour mieux soutenir le corps. Avec de grands avantages pour votre dos.



Il design non è realizzare bellezza: la bellezza emerge da selezione, affinità, integrazione, amore.

Design is not making beauty: beauty emerges from selection, affinities, integration, love.

Le design ne consiste pas seulement à créer de la beauté : la beauté se dégage de la sélection, des affinités, de l'intégration, de l'amour.

Louis Kahn

Profondità
Depth
Profondeur
82
cm

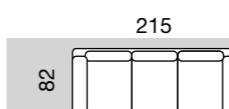

art. 03

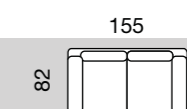

art. 02

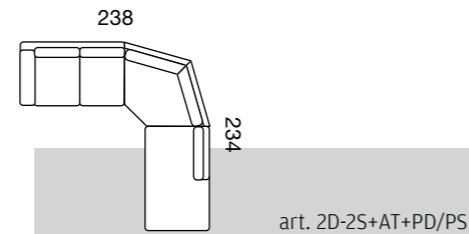

art. 2D-2S+AT+PD/PS

Poggiatesta - Headrest - Appuie-Tête
art. 31 optional

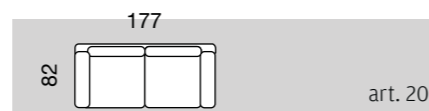

art. 20

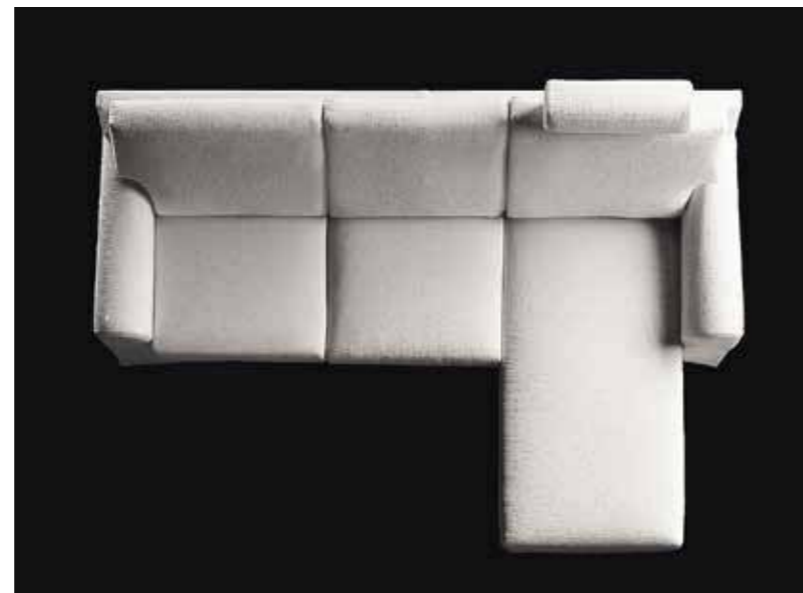
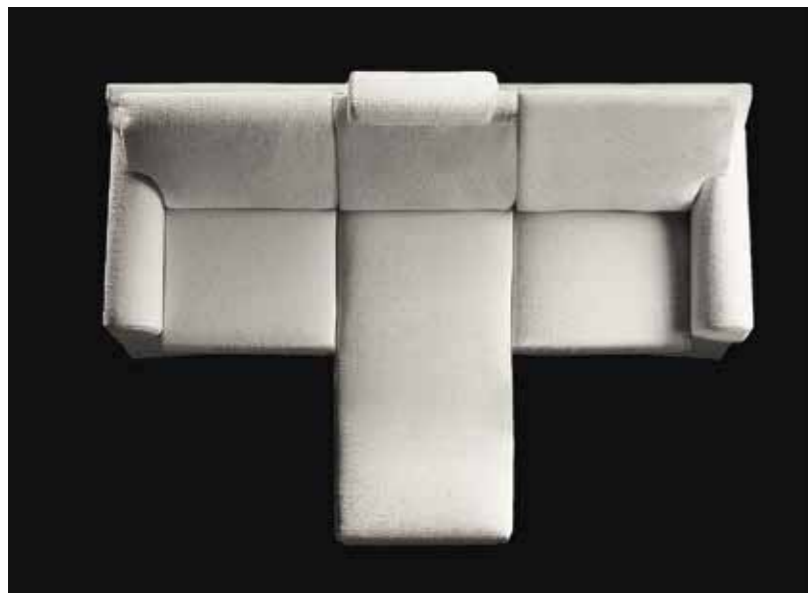

art. P03

Poggiatesta - Headrest - Appuie-Tête
art. 31 optional

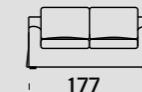
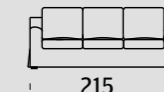
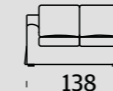
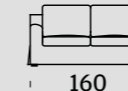
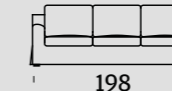
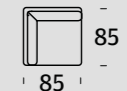
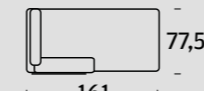
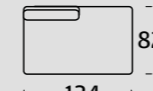
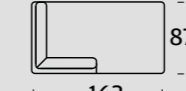
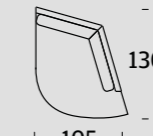
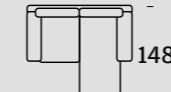
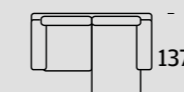
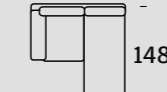
Art. 01
Poltrona
Armchair
FauteuilArt. 02
Divano 2 posti
2-seater sofa
Canapé 2 placesArt. 20
Divano 2 posti grande
2-seater large sofa
Canapé 2 places grandArt. 03
Divano 3 posti
3-seater sofa
Canapé 3 placesArt. 09
Elemento centrale
Central element
ChausseuseArt. 1D-1S
Laterale 1 posto DX-SX
RH-LH 1-seater side el.
Canapé bâtarde 1 place D-GArt. 2D-2S
Laterale 2 posti DX-SX
RH-LH 2-seater side el.
Canapé bâtarde 2 places D-GArt. GD-GS
Laterale 2 posti grande DX-SX
RH-LH 2-seater large side el.
Canapé bâtarde 2 places grand D-GArt. 3D-3S
Laterale 3 posti DX-SX
RH-LH 3-seater side el.
Canapé bâtarde 3 places D-GArt. AT
Angolo aperto
Open corner
Angle ouvertArt. AQ
Angolo quadro
Square corner
Angle carréArt. CD-CS
Chaise Longue DX-SX
RH/LH chaise l.
Mériidienne D-GArt. PD-PS
Penisola laterale DX-SX
RH-LH side peninsular el.
Peninsule latéral D-GArt. LQ-QL
Laterale angolo quadro DX-SX
RH-LH square corner side el.
Canapé bâtarde angle carré D-GArt. LT-TL
Laterale angolo tondo DX-SX
RH-LH round corner side el.
Canapé bâtarde angle rond D-GArt. 13
Pouf rettangolare
Rectangular pouf
Pouf rectangulaireArt. 31
Poggiatesta
Headrest
Appuie-tête
47x15xH13Art. P02
Divano 2 posti piccolo c/penisola
2-seater small sofa with peninsular el.
Canapé 2 places petit avec peninsuleArt. P20
Divano 2 posti grande c/penisola
2-seater large sofa with peninsular el.
Canapé 2 places grand avec peninsuleArt. P03
Divano 3 posti c/penisola
3-seater sofa with peninsular el.
Canapé 3 places avec peninsuleArt. P2D-P2S
Laterale 2 posti DX-SX c/penisola
RH-LH 2-seater side el. with penins. el.
Canapé bâtarde 2 places D-G avec peninsuleArt. PGD-PGS
Laterale 2 posti grande DX-SX c/penisola
RH-LH 2-seater large side el. with penins. el.
Canapé bâtarde 2 places grand D-G avec peninsuleArt. P3D-P3S
Laterale 3 posti 198 DX-SX c/penisola
RH-LH 3-seater side el. with penins. el.
Canapé bâtarde 3 places D-G avec peninsule

• LISTINO PREZZI / PRICE LIST / LISTE DES PRIX pag. 318

Struttura e molleggio

Struttura realizzata con masselli portanti in legno di pioppo o abete di vari spessori. Parti di tamponamento in fibra grezza e/o compensato. Fianchi in agglomerato di legno da 18 mm. Fibra grezza e agglomerato di legno in classe E1, pertanto a bassa emissione di formaldeide. Il tutto rivestito con vellutino 100% poliammide termoaccoppiato ad espanso e/o ovatta di fibra poliestere 100% resinata. Molleggio realizzato con nastri elastici da 80 mm tesi meccanicamente, composti da fili di gomma ricoperti da filo di nylon avvolto a spirale.

Imbottitura

Cuscino seduta in espanso indeformabile D30 e cuscino schienale in espanso D18 indeformabile, entrambi rivestiti con ovatta di fibra di poliestere da 300 g termolegata. Bracciolo in espanso indeformabile D35. Sagomati vari a completamento in espanso D18/21.

Structure and springs

Structure made with bearing parts in poplar or fir wood in various thicknesses. Reinforcing parts made of rough fibre and/or plywood. Sides made of 16 mm thick agglomerated wood chips. Rough fibre and agglomerated wood chips, Class E1 and thus with low formaldehyde emissions. The whole is covered in 100% polyamide velveteen thermocoupled to foam and/or 100% resinated polyester fibre wadding. Spring made of mechanically tightened 80 mm thick elastic bands, composed of rubber threads covered with nylon thread, coiled up in a spiral.

Upholstery

Seat cushion in D30 non deformable foam and backrest cushion in D18 - both covered with 300 g of thermobonded polyester fibre wadding. Armrest cushion in D35 non deformable foam. Various shaped elements in foam to complete with an D18/21.

Structure et suspension

Structure réalisée en panneaux massifs de peuplier ou de sapin de différentes épaisseurs. Éléments de remplissage en fibre brute et/ou en contreplaqué. Côtés en bois aggloméré de 16 mm. Fibre brute et bois aggloméré de classe E1, donc à basse émission de formaldéhyde. Le tout est revêtu de velours 100% polyamide thermiquement associé à expansé et/ou à ouate 100% fibre de résine polyester. Suspension réalisée à l'aide de sangles élastiques de 80 mm tendues mécaniquement, composées de fils de caoutchouc recouverts de fil de nylon enroulé en spirale.

Rembourrage

Coussin d'assise en expansé indeformable de D30 et coussin de dossier en expansé de D18, tous deux revêtus d'ouate de fibre polyester de 300 g associée thermiquement. Accoudoir en expansé indeformable de D35. Différents modèles en complément en expansé de D18/21.

Classico e moderno

Ogni cliente è diverso, ognuno da Felis trova una risposta ai suoi desideri: divani classici o moderni, perfetti per ogni ambiente.

Classic and modern

Each customer is different, everyone finds an answer to their desires here at Felis: classic or modern sofas, perfect for any environment.

Classique et moderne

Chaque client est différent, et Felis répond aux désirs de chacun : canapés classiques ou modernes, parfaits dans tous les contextes.



www.felis.it



Felis

AIDA style

Modernità non consiste nell'adottare quattro mobili quadrati.

Modernity doesn't mean to position four square pieces of furniture.

La modernité ne consiste pas à adopter quatre meubles carrés.

Renzo Piano

Braccioli arcuati e inclinati secondo l'ispirazione dei triclini romani: è il segno che caratterizza Aida. Da notare la forma dei cuscini dello schienale, il cui angolo esterno è particolarmente arrotondato.

Arched arms, with the same degree of inclination of the Roman tricliniums: this is the distinctive mark of Aida. Note the shape of the back pillows: their external corner is particularly rounded.

Accoudoirs cambrés et inclinés selon l'inspiration du triclinium romain: le rêve qui caractérise Aida. À noter, la forme des coussins du dossier, dont l'angle externe est particulièrement arrondi.

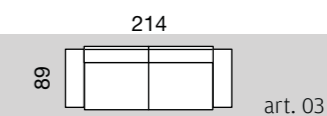

I TESSUTI: UN PUNTO DI FORZA



FABRICS: A STRONG POINT

La gamma di tessuti Style è davvero ampia: filati pregiati, soluzioni tecniche antimacchia a prova di vita quotidiana e colori di tendenza dalle tinte neutre ai colori più audaci.

The range of Style fabrics is really wide: fine yarns, stain-proof technical solutions for everyday life, and trendy colours, from neutral to bold.

LES TISSUS : UN POINT FORT

La gamme des tissus Style est extrêmement vaste : fils précieux, solutions techniques anti-taches pour un usage quotidien et couleurs tendance variant des neutres aux couleurs les plus audacieuses.



IL NUOVO "OLD" STYLE

La rotondità è al centro del carattere di Aida con i suoi braccioli arcuati, i cuscini dello schienale arrotondati...Di gusto classico ma perfetto anche per arredare ambientazioni anche più contemporanee.

THE NEW "OLD" STYLE

Roundness is central to the character of Aida, with its curved armrests and the rounded backrest cushions...The feel is classic, but it is perfect also to decorate even the most contemporary settings.

LE NOUVEAU «OLD» STYLE

La rondeur est au cœur de la nature de Aida avec ses accoudoirs incurvés, les coussins arrondis du dossier... Un style classique mais parfait pour décorer les espaces les plus contemporains.

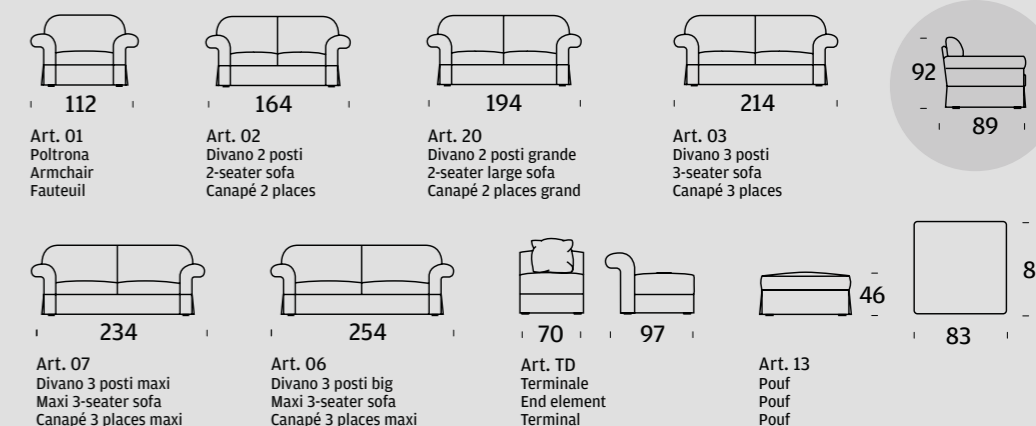
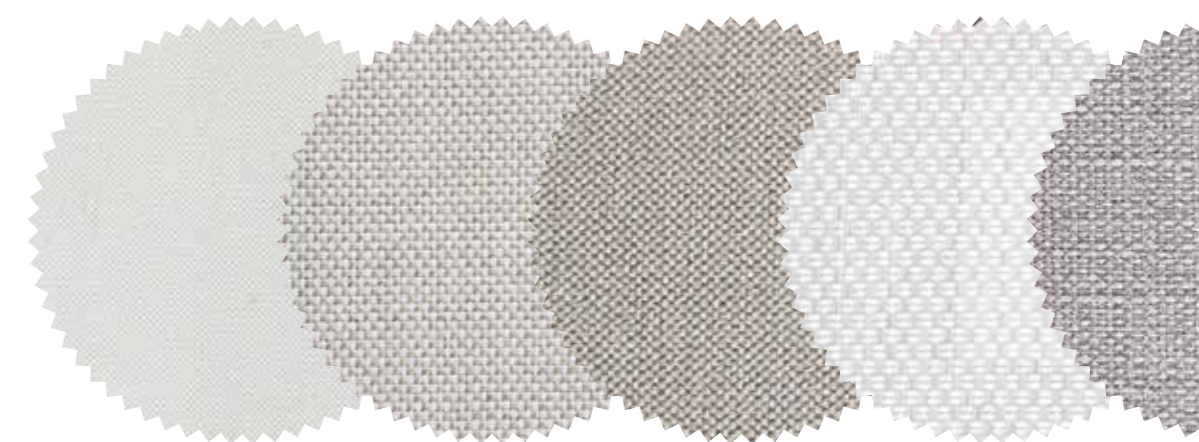

• LISTINO PREZZI / PRICE LIST / LISTE DES PRIX pag. 321

Struttura e molleggio

Masselli portanti in legno di pioppo o abete di vari spessori; parti di tamponamento in fibra grezza e/o compensato. Fianchi in agglomerato di legno da mm 18. Realizzato con particelle di legno a bassa emissione di formaldeide appartenenti alla classe E1. Il tutto è rivestito con vellutino 100% poliammide termoaccoppiato ad espanso e/o ovatta in fibra poliestere 100% resinata. Molleggio realizzato con nastri elastici da 80 mm tesi meccanicamente, composti da fili di gomma ricoperti da filo di nylon avvolto a spirale.

Imbottitura e piedi

I cuscini seduta sono in poliuretano espanso indeformabile D30 rivestito con ovatta di fibra di poliestere da 300 gr termolegata. I cuscini schienale sono in poliuretano espanso D16 sempre rivestito con ovatta di fibra di poliestere da 300 gr termolegata. Tamponi braccioli D21. Piedi in ABS nero.

Frame and springs

Bearing parts in solid fir wood, with various thicknesses; reinforcing parts in rough fibre and/or plywood. Sides made of 18 mm agglomerated chips. Made with wood particles with a low formaldehyde emission (class E1). The whole is covered in 100% polyamide velveteen thermocoupled to foam and/or 100% resin polyester fibre wadding. Springs made with mechanically tightened 80 mm thick elastic bands, composed of rubber threads covered with nylon thread, coiled up in a spiral.

Upholstery and feet

The seat cushions are made of D30 non-deformable polyurethane foam, covered with wadding in thermobond polyester fibre with 300 g weight. The back cushions are made of D16 polyurethane foam, covered with wadding in thermobond polyester fibre with 300 g weight. The armrest pads are still made of D21 non-deformable polyurethane foam. Black ABS feet.

Structure et suspension

Lopins porteurs en bois de peuplier ou de sapin de différentes épaisseurs, parties de remplissage en fibre brute et/ou contreplaqué. Panneaux latéraux en bois aggloméré de 18 mm. Réalisé avec des particules de bois à basse émission de formaldéhydes appartenant à la classe E1. Le tout revêtu de velours 100% polyamide avec couplage thermique à un matériau expansé et/ou à de la ouate de polyester 100% résinée. Suspension réalisée avec des bandes élastiques de 80 mm, tendues mécaniquement et composées de fils de caoutchouc recouverts de fil de nylon enroulé en spirale.

Rembourrage et pieds

Les coussins d'assise sont en polyuréthane expansé indéformable D30 recouvert de ouate de polyester de 300 g, collée à chaud. Les coussins du dossier sont en polyuréthane expansé D16 toujours recouvert de ouate de polyester 300 gr collée à chaud. Tampons accoudoirs toujours en matériau expansé indéformable D21. Pieds en ABS noir.

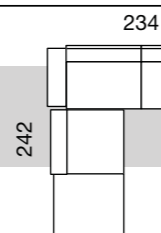

art. 07 + art. TD + art. 13

ASCOT style

GRAZIA CLASSICA

Uno stile semplice e gentile,
ma immediatamente riconoscibile.

CLASSIC GRACE

A simple and gentle style that, however,
can be immediately recognized.

LA GRÂCE DU CLASSIQUE

Un style simple et agréable, mais
immédiatement reconnaissable.

Design è anche guardare gli oggetti di tutti i giorni con occhio curioso.

Design is also looking at objects of everyday life with a curious eye.

Le design, c'est également regarder les objets de la vie quotidienne avec un œil curieux.

Vico Magistretti

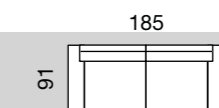

art. 20

CLASSIC FABRICS COLLECTION

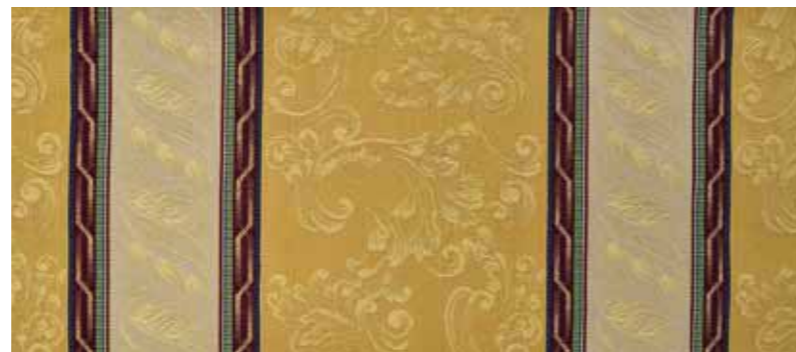
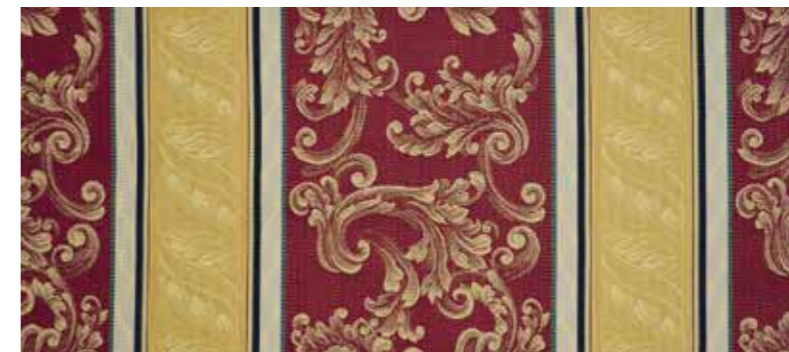
Art. Loto - cat. **LUSSO**

UN TOCCO DI ROMANTICISMO

A TOUCH OF ROMANCE

Il divano classico caratterizzato dai braccioli a "ricciolo" ricrea un'ambientazione romantica. Coordinato ad arredi dai colori pastello.

A classic sofa characterized by "curved" armrests recreates a romantic setting. Pair it with furniture in pastel colours.

UNE TOUCHE DE ROMANTISME

Le canapé classique caractérisé par des accoudoirs à « frisette » recrée un cadre romantique. Coordonnez-le à des meubles couleurs pastel.



Art. 01
Poltrona
Armchair
Fauteuil

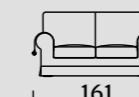

Art. 02
Divano 2 posti
2-seater sofa
Canapé 2 places



Art. 20
Divano 2 posti grande
2-seater large sofa
Canapé 2 places grand



Art. 03
Divano 3 posti
3-seater sofa
Canapé 3 places

• LISTINO PREZZI / PRICE LIST / LISTE DES PRIX pag. 322

Struttura e molleggio

Masselli portanti in legno di pino o abete di vari spessori. Parti di tamponamento in fibra grezza e/o compensato. Fianchi in agglomerato di legno da 18 mm. Realizzato con particelle di legno a bassa emissione di formaldeide, appartenenti alla classe E1. Il tutto è rivestito con vellutino 100% poliammide termoaccoppiato ad espanso e/o ovatta in fibra di poliestere 100% resinata. Molleggio realizzato con nastri elastici da 80 mm tesi meccanicamente, composti da fili di gomma ricoperti da filo di nylon avvolto a spirale.

Imbottitura

Cuscino seduta in espanso indeformabile in D25/S e rivestito con ovatta di fibra di poliestere da g 300 termolegata. Cuscino schienale in espanso indeformabile D15 sempre rivestito con ovatta di fibra di poliestere da g 300 termolegata. Tamponi bracciolo e sagomati vari sempre in espanso indeformabile D21.

Structure and springs

Bearing parts in poplar or fir wood, with various thicknesses. Reinforcing parts made of rough fibre and/ or plywood. Sides made of agglomerated chips with 18 mm thickness. Made of wood particles with low formaldehyde emission, belonging to the E1 class. The whole is covered in 100% polyamide velveteen thermocoupled to foam and/or wadding in 100% resin polyester fibre. Spring made of mechanically tightened elastic bands with 80mm thickness, composed of rubber threads covered with nylon thread, coiled up in a spiral.

Upholstery

Seat pillow in indeformable foam, with D25/S and covered with wadding in 300 g thermobond polyester fibre. Seat pillow in indeformable foam, with D15, always covered with wadding in 300 g thermobond polyester fibre. Reinforcing parts for the arm and various shaped elements, also made of indeformable foam with D21.

Structure et suspension

Duramens portants en bois de peuplier ou de sapin, d'épaisseurs différentes. Parties de fileurs en fibre brute et/ou contreplaqué. Côtés en bois aggloméré de 18 mm. Réalisés avec des particules de bois à basse émission de formaldéhyde, appartenant à la classe E1. Le tout est revêtu de velours 100% polyamide associé thermiquement à l'expansé et/ou ovate en fibres de polyester 100% résine. Suspension réalisée avec des bandes élastiques de 80 mm, tendues mécaniquement, composées de fils de caoutchouc recouverts de fil de nylon enroulé en spirale.

Rembourrage

Coussin de l'assise en expansé indéformable de D25/S et revêtu de ovate de fibre de polyester de 300 g associée thermiquement. Coussin du dossier en expansé indéformable de D15 toujours revêtu de ovate de fibre de polyester de 300 g associée thermiquement. Fileurs accouider et façonnés divers, toujours en expansé indéformable D21.

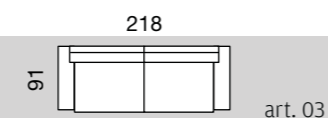
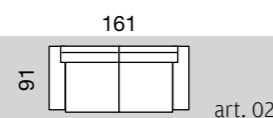

GRAY style

Architettura è sublimazione delle necessità della vita.

Architecture is the sublimation of life's necessities.

L'architecture est la sublimation des nécessités de la vie.

Ernesto N. Rogers

SEMPLICEMENTE ARMONIOSO.

Proporzioni studiate, nella semplicità delle forme classiche. Un classico intramontabile del buon gusto.

SIMPLY HARMONIOUS.

Carefully designed proportions, with the simplicity of classic shapes. A timeless classic of good taste.

SIMPLEMENT HARMONIEUX.

Des proportions étudiées, dans la simplicité des formes classiques. Un classique intemporel du bon goût.



213

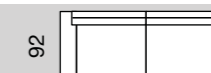

art. 03

CLASSIC FABRICS COLLECTION

Art. Loto - cat. **LUSSO**

TOTALE COORDINAZIONE

Da notare il tessuto diverso ma coordinato con cui viene rivestita la struttura rispetto ai cuscini di schienale e seduta.

TOTAL COORDINATION

Note that the structure is covered in different fabrics, but coordinated to that of the pillows of the back and seat.

COORDINATION ABSOLUE

À noter, le tissu différent mais coordonné qui recouvre la structure, par rapport aux coussins du dossier et de l'assise.



Art. 01
Poltrona
Armchair
Fauteuil

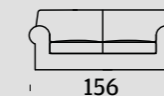

Art. 02
Divano 2 posti
2-seater sofa
Canapé 2 places

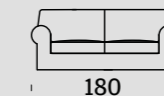

Art. 20
Divano 2 posti grande
2-seater large sofa
Canapé 2 places grand

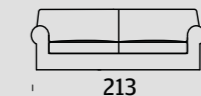

Art. 03
Divano 3 posti
3-seater sofa
Canapé 3 places



Art. 09
Elemento centrale
Central element
Chauffeuse



Art. 1D-1S
Laterale 1 posto DX-SX
RH-LH 1-seater side el.
Canapé bâtarde 1 place D-G



Art. MD-MS
Laterale 1 posto maxi DX-SX
RH-LH maxi 1-seater side el.
Canapé bâtarde 1 place maxi D-G

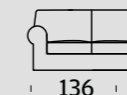

Art. 2D-2S
Laterale 2 posti DX-SX
RH-LH 2-seater side el.
Canapé bâtarde 2 places D-G

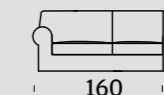

Art. GD-GS
Laterale 2 posti grande DX-SX
RH-LH 2-seater large side el.
Canapé bâtarde 2 places grand D-G

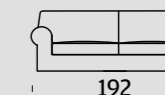

Art. 3D-3S
Laterale 3 posti DX-SX
RH-LH 3-seater side el.
Canapé bâtarde 3 places D-G



Art. AT
Angolo tondo
Rounded corner
Angle rond



Art. AQ
Angolo quadro
Square corner
Angle carré

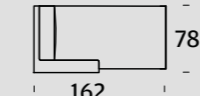

Art. CD-CS
Chaise longue reversibile DX-SX
Reversible chaise longue, maxi, RH-LH
Chaise longue réversible D-G



Art. CM-MC
Chaise longue maxi reversibile DX-SX
Reversible chaise longue, maxi, RH-LH
Chaise longue maxi réversible D-G



Art. 13
Pouf rettangolare
Rectangular pouf
Pouf rectangulaire



Art. 31
Poggiatesta
Headrest
Appuie-tête
47x15xH13

• LISTINO PREZZI / PRICE LIST / LISTE DES PRIX pag. 323

Struttura e molleggio

Masselli portanti in legno di pino o abete di vari spessori; parti di tamponamento in fibra grezza e/o compensato. Fianchi in agglomerato di legno da mm 18. Realizzato con particelle di legno a bassa emissione di formaldeide appartenenti alla classe E1. Il tutto è rivestito con vellutino 100% poliammide termocoppato ad espanso e/o ovatta in fibra poliestere 100% resinata. Molleggio realizzato mediante nastri elastici da 80 mm tesi meccanicamente, composti da fili di gomma ricoperti da filo di nylon avvolto a spirale.

Imbottitura

Cuscino seduta in espanso indeformabile in D25/S e rivestito con ovatta di fibra di poliestere da g 300 termolegata. Cuscino schienale in espanso indeformabile D15 sempre rivestito con ovatta di fibra di poliestere da g 300 termolegata. Tamponi bracciolo e sagomati vari sempre in espanso indeformabile D21.

Structure and springs

Bearing parts in solid fir wood, with various thicknesses; reinforcing parts in rough fibre and/or plywood. Sides made of 18 mm agglomerated chips. The whole is made of wood particles with low formaldehyde emission (belonging to the E1 class). The whole is covered in 100% polyamide velveteen thermocoupled to foam and/or 100% resin polyester fibre wadding. Spring made of mechanically tightened elastic bands with 80mm thickness, composed of rubber threads covered with nylon thread, coiled up in a spiral.

Upholstery

Seat pillow in indeformable foam, with D25/S and covered with wadding in 300 g thermobond polyester fibre. Seat pillow in indeformable foam, with D15, always covered with wadding in 300 g thermobond polyester fibre. Reinforcing parts for the arm and various shaped elements, also made of indeformable foam with D21.

Structure et suspension

Réalisée en panneaux massifs en bois de peuplier ou de sapin de plusieurs épaisseurs; parties de fileurs en fibre brute et/ou contreplaqué. Côtés en bois aggloméré de 18 mm. Réalisé avec des particules de bois à basse émission de formaldéhyde appartenant à la classe E1. Le tout est revêtu de velours 100% polyamide associé thermiquement à l'expansé et/ou à la ouate en fibre de polyester 100% résine. Suspension réalisée avec des bandes élastiques de 80 mm, tendues mécaniquement, composées de fils de caoutchouc recouverts de fil de nylon enroulé en spirale.

Rembourrage

Coussin de l'assise en expansé indeformable de D25/S et revêtu de ouate de fibre de polyester de 300 g associée thermiquement. Coussin du dossier en expansé indeformable de D15 toujours revêtu de ouate de fibre de polyester de 300 g associée thermiquement. Fileurs accoudoir et façonnés divers, toujours en expansé indeformable D21.

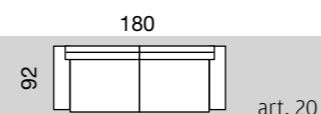

BOLERO

style

L'architettura è l'espressione fisica di un modo di essere.

The architecture is the physical expression of a way of being.

L'architecture est l'expression physique de la façon d'être.

John Pawson

ROTONDA ELEGANZA

Curve, linee sinuose, morbidezza: questo in tre parole è Bolero. Un divano che come una conchiglia ti accoglie con eleganza. Coordinato al divano, il pouf ellittico che ti permette di giocare con le forme ricurve.

ROUND ELEGANCE

Curvy, voluptuous, soft: this is Bolero in three words. A sofa that welcomes you with elegance like a shell. Paired with the sofa, the elliptical pouf allows you to play with the curved shapes.

RONDE ÉLÉGANCE

Courbes, sinuosité, moelleux : en trois mots, Bolero. Un canapé comme une coquille, qui vous accueille avec élégance. Coordonné au canapé, le pouf elliptique qui vous permet de jouer avec les formes courbes.

MANY
SOLUTIONS,
LOW PRICE

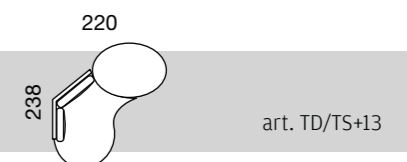
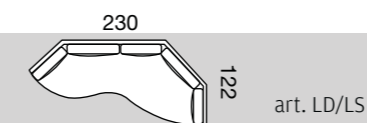
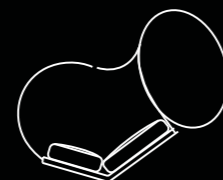
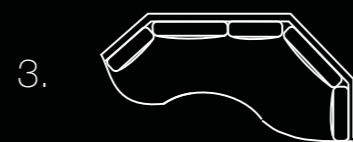
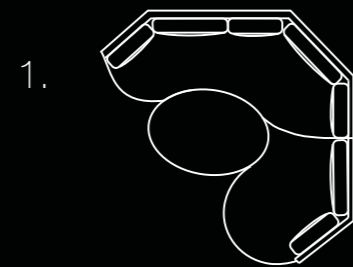

TUTTA UNA CURVA

Bolero è un divano che permette di giocare con le sue forme ricurve: un gioco di incastri che ha come protagonista il pouf ellittico. Per un design a tutto tondo.

CURVES ONLY

Bolero is a sofa which makes it possible to play with curved shapes: a game of shapes to be fitted together, with the elliptical pouf as a protagonist. For an all-round design.

EN UNE COURBE

Bolero est un canapé permettant de jouer avec ses formes recourbées : un jeu d'encastrement avec au centre, le pouf elliptique. Pour un design tout en rond.



OPTIONAL: Cuscino quadrato Art. 16 e tondo Art. 27
Square cushion Art. 16 and round cushion Art. 27
Coussin carré Art. 16 et rond Art. 27

art. 27

art. 27

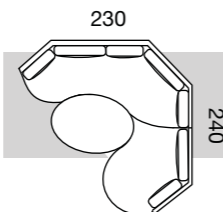

art. LD/LS+TD/TS+13

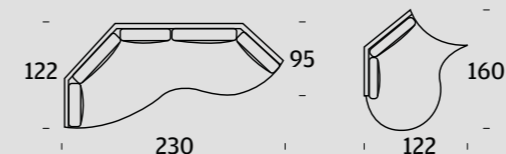

Art. LD-LS
Laterale angolo DX-SX
RH-LH corner side el.
Canapé bâtarde angle D-G

Compresi 5 cuscini schiena
5 back cushion included
5 coussin dossier compris

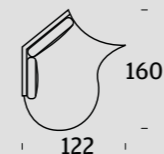

Art. TD-TS
Terminale DX-SX
RH-LH end el.
Terminal D-G

Compresi 2 cuscini schiena
2 back cushion included
2 coussin dossier compris



Art. 13
Pouf Ovale
Oval pouf
Pouf ovale

• LISTINO PREZZI / PRICE LIST / LISTE DES PRIX pag. 325

Aggiungi il pouf ovale
coordinato

Aggiungi il pouf ovale
coordinato

Ajoutez le pouf ovale
coordonné

Struttura e molleggio

Struttura realizzata con masselli portanti in legno di pioppo o abete di vari spessori. Parti di tamponamento in fibra grezza e/o compensato. Fianchi in agglomerato di legno da 18 mm. Fibra grezza e agglomerato di legno appartengono alla classe E1, pertanto a bassa emissione di formaldeide. Il tutto rivestito con vellutino 100% poliammide termoaccoppiato ad espanso e/o ovatta di fibra poliestere 100% resinata. Molleggio realizzato con nastri elastici da 80 mm tesi meccanicamente, composti da fili di gomma ricoperti da filo di nylon avvolto a spirale.

Imbottitura e piedi

Imbottitura cuscini seduta in espanso indeformabile D30, rivestiti con ovatta in fibra di poliestere 100% da 300g termolegata. Schienali in fiocco di poliestere contenuto in rivestimento di tessuto non tessuto. Lastre di completamento in espanso D25 e D40 indeformabile. Piedini in legno a sfera tinta naturale.

Structure and springs

Structure made with bearing parts in poplar or fir wood, with various thicknesses. Reinforcing parts made of rough fibre and/ or plywood. Sides made of agglomerated chips with 18 mm thickness. Rough fibre and agglomerated chips belong to the E1 class, and therefore have a low formaldehyde emission. The whole is covered in 100% polyamide velveteen thermocoupled to foam and/or wadding in 100% polyester fibre with resin finish. Springing made of mechanically tightened elastic bands with 80mm thickness, composed of rubber threads covered in nylon thread, coiled up in a spiral.

Upholstery and feet

Upholstery seat pillows in indeformable foam with D30, covered with wadding in thermobond polyester fibre, 300g weight. Back in polyester flakes, in a covering made of tissue-non-tissue. Completing sheets in indeformable foam with D25 and D40. Spherical feet made of wood, with a natural colour.

Structure et suspension

Structure réalisée avec duraments portants en bois de peuplier ou de sapin, d'épaisseurs différentes. Parties de fileurs en fibre brute et/ou contreplaqué. Côtés en bois aggloméré de 18 mm. La fibre brute et le bois aggloméré appartiennent à la classe E1 et donc ils sont à basse émission de formaldéhyde. Le tout est revêtu de velours 100% polyamide associé thermiquement à l'expansé et/ou ouate en fibres de polyester 100% résine. Suspension réalisée avec des bandes élastiques de 80 mm tendues mécaniquement, composées de fils de caoutchouc recouverts de fil de nylon enroulé en spirale.

Rembouillage et pieds

Rembouillage coussini de l'assise en expansé indeformabile D30, revêtus de ouate en fibre de polyester 100% de 300 g associée thermiquement. Dossiers en flocon de polyester contenu dans un revêtement de tissu non tissé. Plaques d'achèvement en expansé D25 et D40 indeformabile. Pieds en bois à billes, coloris naturel.

Tessuto ed ecopelle

Vero punto di forza di Felis sono i tessuti, in centinaia di varianti. Nuovo orizzonte, l'ecopelle: ecologica, moderna, resistente.

Fabric and eco-leather

The real strength of Felis are its fabrics, with hundreds of varieties. A new horizon, eco-leather: ecological, modern and durable.

Tissu et simili cuir

Les tissus sont la véritable force de Felis, avec des centaines de variations. Un nouvel horizon, le simili cuir : écologique, moderne et résistant.

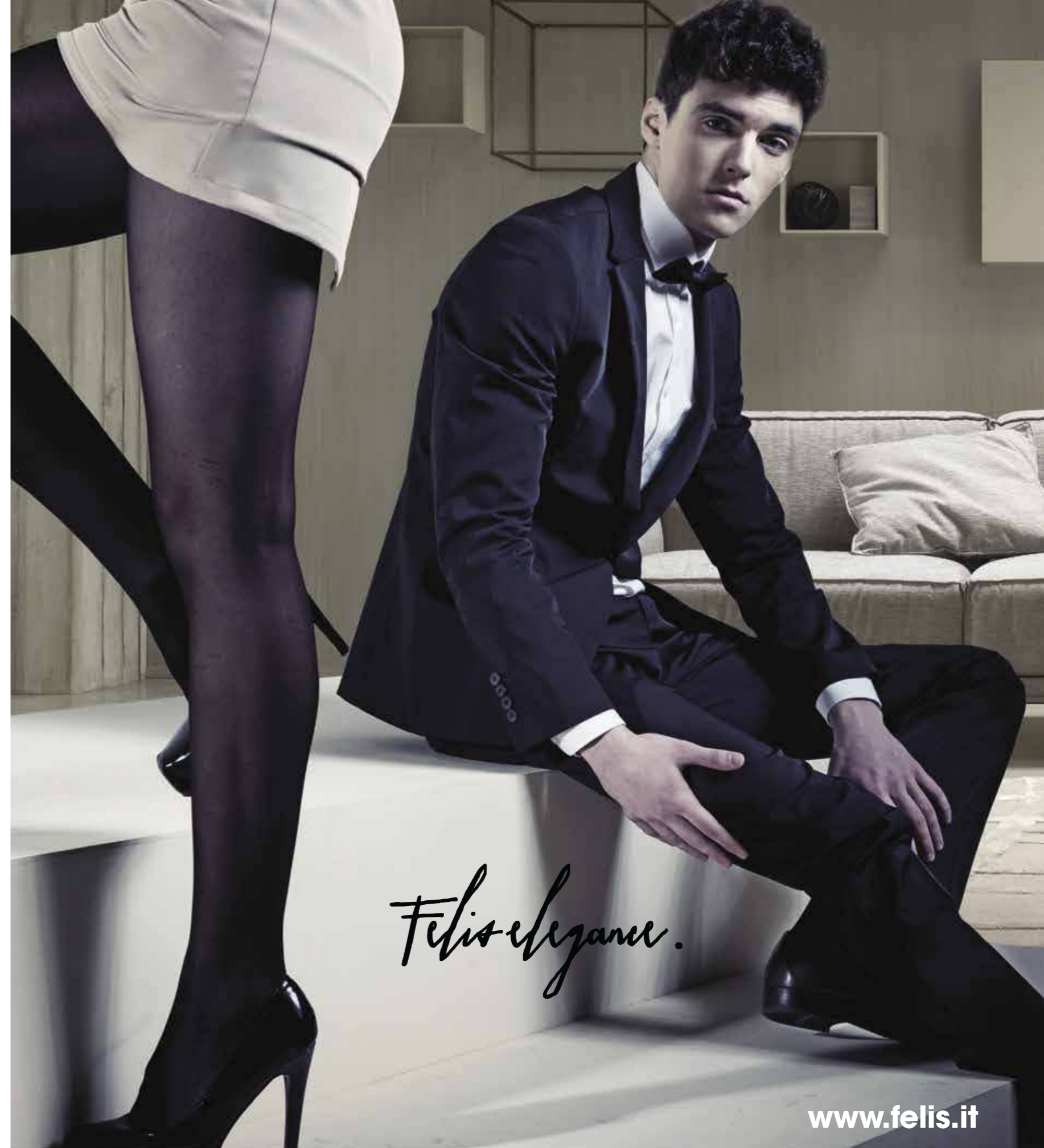

www.felis.it



Felis



DAY &
NIGHT

DOLCE SOGNARE style

MODERN COLLECTION

New!



Jack



Kurt



Jim



Mark



Bob



Sven



Grace



Janis



John



Schienale con cricchetto opzionale in tutti i modelli della collezione

Optional backrest with ratchet on all models of the collection

Dossier avec option de cliquet sur tous les modèles de la collection

NOTTE PER UNO... ANZI, PER DODICI!

Se pensi che scegliere un divano letto vuol dire dover accettare un compromesso fra la comodità del divano e la qualità del letto, non conosci la linea divani letto Dolce Sognare. Design e comodità di giorno, perfezione e qualità di notte.

NIGHT FOR ONE... INDEED, FOR TWELVE!

If you think that, choosing a sofa bed means having to accept a compromise between the comfort of the sofa and the quality of the bed, you do not know the Dolce Sognare line of sofa beds. Design and comfort during the day, perfection and quality at night.

DOUCE NUIT POUR UN... NON, DOUZE !

Si vous pensez que choisir un canapé-lit signifie devoir accepter un compromis entre confort du canapé et qualité du lit, vous ne connaissez pas encore les canapés-lits de la ligne Dolce Sognare. Design et confort pendant la journée, perfection et qualité durant la nuit.

CONTEMPORARY COLLECTION



Mick



Tom



Steve

JACK style

DESIGN E TECNOLOGIA

Moderno, quasi futuristico ed estremamente confortevole. Jack è un divano letto dai dettagli molto accurati come il cordoncino che rifinisce i suoi contorni. Al design si unisce anche la tecnologia perché può essere dotato di un meccanismo con cricchetto che permette di appoggiare in modo confortevole il collo.

DESIGN AND TECHNOLOGY

Modern, almost futuristic and extremely comfortable. Jack is a sofa bed with very accurate details like the cord that finishes its contours. Design also meets technology, because it can be fitted with a ratchet mechanism that allows you to rest your neck more comfortably.

DESIGN ET TECHNOLOGIE

Moderne, presque futuriste et extrêmement confortable. Jack est un canapé-lit avec des détails aussi précis que le cordon qui termine ses contours. Le design s'unit également à la technologie avec la possibilité d'associer un mécanisme à cliquet permettant d'appuyer confortablement le cou.



New!



OPTIONAL: Schienale con cricchetto
Backrest with ratchet
Dossier à cliquet



art. 03



art. 07



New!

Optional cricchetto
Optional ratchet
movement
Mouvement à cliquet
en option

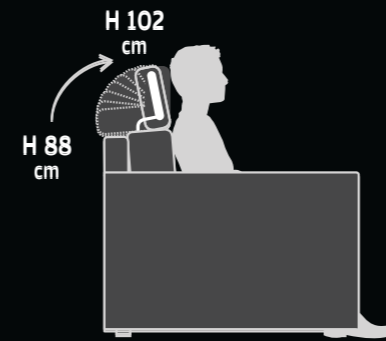

Disponibile anche
in versione fissa
Also available in
the fixed version
Également disponible
en version fixe

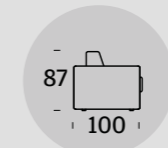

Art. 01 Poltrona/Letto Chair bed Fauteuil convertible	Art. 02 Divano/letto 2 posti 2-seater sofa bed Canapé convertible 2 places	Art. 20 Divano/letto 2 posti grande 2-seater large sofa bed Canapé convertible 2 grandes pl.	Art. 03 Divano/letto 3 posti 3-seater sofa bed Canapé convertible 3 places	Art. 07 Divano/letto 3 posti maxi Maxi 3-seater sofa bed Canapé convertible 3 places maxi		
25 143 ↓ 210 197 70	173 ↓ 197 100	193 ↓ 197 120	213 ↓ 197 140	233 ↓ 197 160		
Art. 1D-1S Laterale/letto 1 posto RH-LH 1-seater side el. Canapé bâtarde 1 place D-G	Art. 2D-2S Laterale/letto 2 posti RH-LH 2-seater side el. Canapé bâtarde 2 places D-G	Art. 6D-6S Laterale/letto 2 posti grande RH-LH 2-seater large side el. Canapé bâtarde 2 grandes pl. D-G	Art. 3D-3S Laterale/letto 3 posti RH-LH 3-seater side el. Canapé bâtarde 3 places D-G	Art. 7D-7S Laterale/letto 3 posti maxi RH-LH maxi 3-seater side el. Canapé bâtarde 3 maxi places D-G		
118 ↓ 210 197 70	148 ↓ 197 100	168 ↓ 197 120	188 ↓ 197 140	208 ↓ 197 160		
Art. CD-CS Chaise longue RH-LH chaise longue Mériidienne D-G	Art. XD-XS Chaise longue c/contenitore RH-LH chaise longue with storage Mériidienne D-G rangement	Art. TD-TS Terminale End element Terminal	Art. TP-PT Terminale con penisola End element with peninsular el. Terminal avec peninsule	Art. 13 Pouf Pouf	Art. 17 Cuscino schienale con supporto per el. terminale Back cushion with support for end el. Cousin dossier a/support pour elem. term. 56x24xH38	Art. 18 Cuscino rettangolare Rectangular cushion Cousin rectangulaire 23x60
109 ↓ 160 160	109 ↓ 160 160	98 ↓ 160 202	98 ↓ 160 82	62 82		

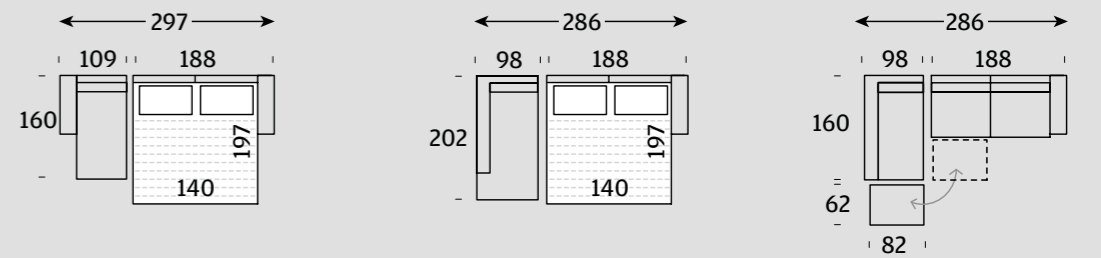

COMFORT IN 15 POSIZIONI

Jack è il divano che come optional è dotato di un meccanismo con cricchetto che garantisce a tutti di assumere la posizione preferita perché si sposta in 15 posizioni diverse. Tutte perfette per il relax del collo.

COMFORT IN 15 POSITIONS

Jack is a sofa which is optionally equipped with a ratchet mechanism making it possible to assume one's preferred position because it moves in 15 different ways. All of which, perfect for neck relaxation.

LE CONFORT EN 15 POSITIONS

Jack est le canapé proposant, en option, un mécanisme de cliquet permettant de garantir à tout un chacun de s'installer comme il le préfère en utilisant les 15 positions disponibles. Toutes parfaites pour détendre la nuque.

PERSONALITA' DECISA

Le forme futuristiche di Jack sono accentuate dal prezioso dettaglio del cordoncino che rifinisce i contorni del divano. Il colore a contrasto lo rende una scelta forte di design, capace di caratterizzare l'intero salotto.

STRONG PERSONALITY

The futuristic shapes of Jack are accentuated by the precious detail of the cord that refines the contours of the sofa. The contrasting colour makes it a strong choice of design, which can give character to the entire living room.

PERSONNALITÉ DÉTERMINÉE

Les formes futuristes de Jack sont accentuées par le détail précieux apporté par le cordon finissant les contours du canapé. La couleur contrastante lui procure un caractère hautement design, capable de donner du caractère à l'ensemble du salon.

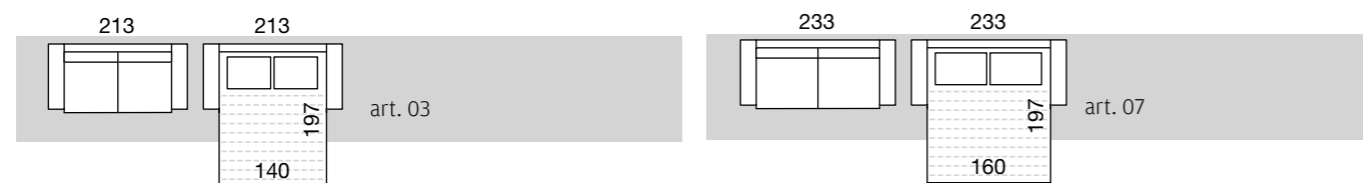

KURT style

L'architettura è la volontà dell'epoca tradotta nello spazio.

Architecture is the will of the epoch translated into space.

L'architecture est la volonté de l'époque traduite dans l'espace.

Ludwig Mies Van der Rohe

ESTETICA ESSENZIALE

Lineare, ampio con impunture ad impreziosire il contorno. Kurt è un divano letto componibile coordinabile con penisole e pouf. Dotato di meccanica servoassistita, la sua apertura è semplificata mediante la rotazione dello schienale.

ESSENTIAL BEAUTY

Linear, ample, with contours embellished by stitching. Kurt is a sectional sofa to be matched with peninsulas and pouf. Equipped with a power-assisted mechanism, its opening is simplified by rotating the back.

ESTHÉTISME ESSENTIEL

Linéaire et ample avec des coutures pour embellir la silhouette. Kurt est un canapé-lit modulaire pouvant être coordonné avec des péninsules et des poufs. Doté d'un mécanisme à commande assistée, son ouverture est simplifiée par la rotation du dossier.

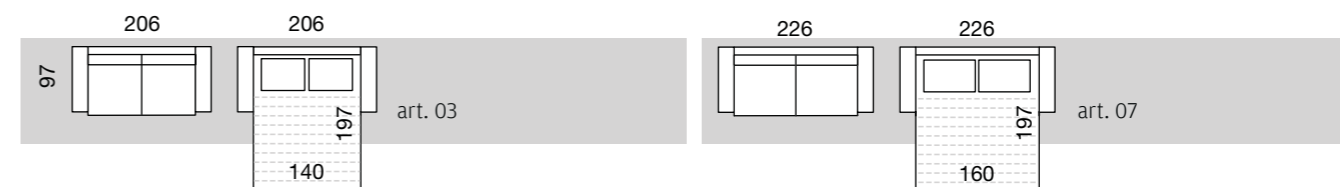

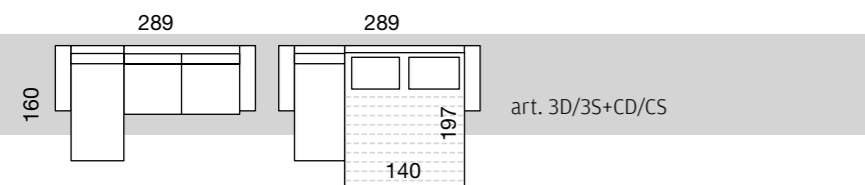

OPTIONAL: con contenitore with container / avec rangement art. XD/XS

Optional cricchetto
Optional ratchet
movement
Mouvement à cliquet
en option

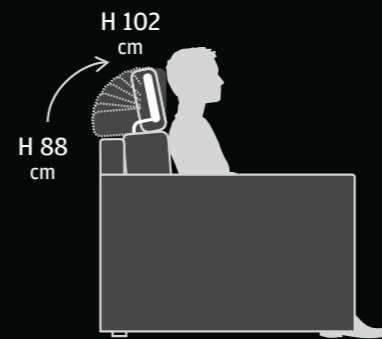

Disponibile anche
in versione fissa
Also available in
the fixed version
Également disponible
en version fixe

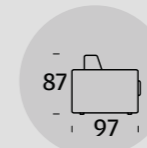

<p>Art. 01 Poltrona/Letto Chair bed Fauteuil convertible</p> <p>136 197 70</p>	<p>Art. 02 Divano/letto 2 posti 2-seater sofa bed Canapé convertible 2 places</p> <p>166 197 100</p>	<p>Art. 20 Divano/letto 2 posti grande 2-seater large sofa bed Canapé convertible 2 grandes pl.</p> <p>186 197 120</p>	<p>Art. 03 Divano/letto 3 posti 3-seater sofa bed Canapé convertible 3 places</p> <p>206 197 140</p>	<p>Art. 07 Divano/letto 3 posti maxi Maxi 3-seater sofa bed Canapé convertible 3 places maxi</p> <p>226 197 160</p>		
<p>Art. 1D-1S Laterale/letto 1 posto RH-LH 1-seater side el. Canapé bâtarde 1 place D-G</p> <p>114 197 70</p>	<p>Art. 2D-2S Laterale/letto 2 posti RH-LH 2-seater side el. Canapé bâtarde 2 places D-G</p> <p>144 197 100</p>	<p>Art. GD-GS Laterale/letto 2 posti grande RH-LH 2-seater large side el. Canapé bâtarde 2 grandes pl. D-G</p> <p>164 197 120</p>	<p>Art. 3D-3S Laterale/letto 3 posti RH-LH 3-seater side el. Canapé bâtarde 3 places D-G</p> <p>184 197 140</p>	<p>Art. 7D-7S Laterale/letto 3 posti maxi RH-LH maxi 3-seater side el. Canapé bâtarde 3 maxi places D-G</p> <p>204 197 160</p>		
<p>Art. CD-CS Chaise longue RH-LH chaise longue Méristienne D-G</p> <p>105 160 160</p>	<p>Art. XD-XS Chaise longue c/contenitore RH-LH chaise longue with storage Méristienne D-G rangement</p> <p>105 160 160</p>	<p>Art. TD-TS Terminale End element Terminal</p> <p>98 160 202</p>	<p>Art. TP-PT Terminale con penisola End element with peninsular el. Terminal avec peninsule</p> <p>82 62</p>	<p>Art. 13 Pouf Pouf</p> <p>82</p>	<p>Art. 17 Cuscino schienale con supporto per el. terminale Back cushion with support for end el. Cousin dossier a/support pour elem. term. 56x24xH38</p> <p>23x60</p>	<p>Art. 18 Cuscino rettangolare Rectangular cushion Cousin rectangulaire</p> <p>23x60</p>
<p>289</p> <p>105 184 197 160 140</p>		<p>282</p> <p>98 184 197 202 140</p>		<p>282</p> <p>98 184 197 160 62 82</p>		

PRATICO CONTENITORE

Non solo bello da vedere e facile da usare ma anche pratico grazie all'ampio contenitore facilmente accessibile, utile per riporre cuscini, guanciali e coperte.

PRACTICAL CONTAINER

Not only beautiful to look at and easy to use, but also practical thanks to the large container easily accessible, useful for storing cushions, pillows and blankets.

RANGEMENT PRATIQUE

Beau à regarder et facile à utiliser, mais également pratique grâce à son grand rangement facilement accessible, utile pour ranger les coussins, les oreillers et les couvertures.



JIM style

Dormire è distrarsi dal mondo.

To sleep is to get distracted from the world.

Dormir, c'est se distraire du monde - Jorge Luis Borges

È FACILE CAMBIARE

Jim è un divano che riscrive in chiave moderna l'ideale del comfort assoluto. Divano letto dalla componibilità elevata, coordinabile con penisole e pouf, Jim è dotato di meccanica servoassistita, apertura semplificata mediante la rotazione dello schienale, sfoderabilità totale.

IT'S EASY TO CHANGE

Jim is a sofa that rewrites the ideal of absolute comfort in a modern way. A sofa bed with a high modularity, to be paired with peninsulas and pouf, Jim has a power assisted mechanism, opening simplified by rotating the back, completely removable covers.

C'EST FACILE DE CHANGER

Jim est un canapé qui revisite l'idéal du confort absolu en version moderne. Canapé-lit à grande modularité, pouvant être coordonné avec des péninsules et des poufs, Jim est doté d'un système mécanique à commande assistée et d'une ouverture simplifiée par simple rotation du dossier, entièrement déhoussable.

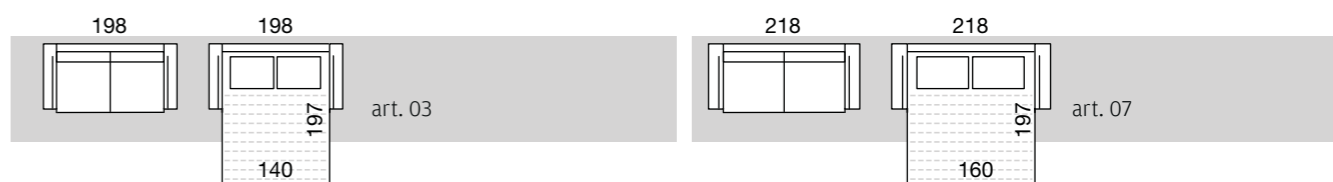



Il cuscino removibile fa da schienale e trasforma il divano.
The removable cushion acts as a backrest and transforms the sofa.
Le coussin amovible sert de dossier et transforme le canapé

Optional cricchetto
Optional ratchet movement
Moviment à cliquet en option

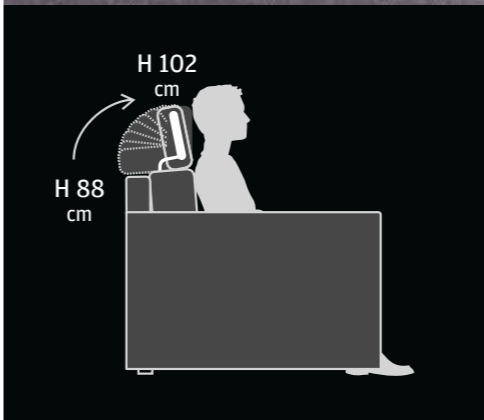

Disponibile anche in versione fissa
Also available in the fixed version
Également disponible en version fixe

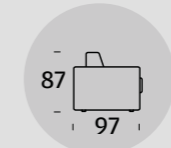

Art. 01 Poltrona/Letto Chair bed Fauteuil convertible	Art. 02 Divano/letto 2 posti 2-seater sofa bed Canapé convertible 2 places	Art. 20 Divano/letto 2 posti grande 2-seater large sofa bed Canapé convertible 2 grandes pl.	Art. 03 Divano/letto 3 posti 3-seater sofa bed Canapé convertible 3 places	Art. 07 Divano/letto 3 posti maxi Maxi 3-seater sofa bed Canapé convertible 3 places maxi		
17 128 210 70	158 197 100	178 197 120	198 197 140	218 197 160		
Art. 1D-1S Laterale/letto 1 posto RH-LH 1-seater side el. Canapé bâtarde 1 place D-G	Art. 2D-2S Laterale/letto 2 posti RH-LH 2-seater side el. Canapé bâtarde 2 places D-G	Art. GD-GS Laterale/letto 2 posti grande RH-LH 2-seater large side el. Canapé bâtarde 2 grandes pl. D-G	Art. 3D-3S Laterale/letto 3 posti RH-LH 3-seater side el. Canapé bâtarde 3 places D-G	Art. 7D-7S Laterale/letto 3 posti maxi RH-LH maxi 3-seater side el. Canapé bâtarde 3 maxi places D-G		
110 197 70	140 197 100	160 197 120	180 197 140	200 197 160		
Art. CD-CS Chaise longue RH-LH chaise longue Mériidienne D-G	Art. XD-XS Chaise longue c/contenitore RH-LH chaise longue with storage Mériidienne D-G rangement	Art. TD-TS Terminale End element Terminal	Art. TP-PT Terminale con penisola End element with peninsular el. Terminal avec peninsula	Art. 13 Pouf Pouf	Art. 17 Cuscino schienale con supporto per el. terminale Back cushion with support for end el. Coussin dossier a/support pour elem. term. 56x24xH38	Art. 18 Cuscino rettangolare Rectangular cushion Cousin rectangulaire 23x60
101 160 160	101 160 160	98 160 202	98 160 202	82 62		
281 101 180 160 197 140		278 98 180 202 197 140		278 98 180 160 197 62 82		



TANTA NATURALIZZA

Per una casa impostata sui toni naturali si potranno inserire arredi e complementi realizzati in materiali naturali oltre a tessuti d'arredo e cuscini in nuance. Il risultato sarà un ambiente elegante e raffinato con uno spiccato richiamo alla natura.

PLENTY OF NATURALNESS

For a house set on natural tones, you can insert furniture and accessories made from natural materials, as well as furnishing fabrics and pillows in nuance. The result is a refined and elegant atmosphere with a strong reference to nature.

LE NATUREL EN QUANTITÉ

Pour une maison aux tonalités naturelles, il est possible d'insérer des meubles et des accessoires fabriqués à partir de matériaux naturels ou encore des tissus d'ameublement et des coussins nuancés. Le résultat sera une ambiance raffinée et élégante avec un fort hommage à la nature.

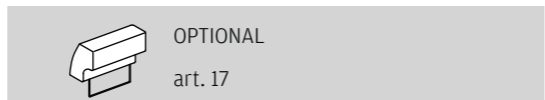
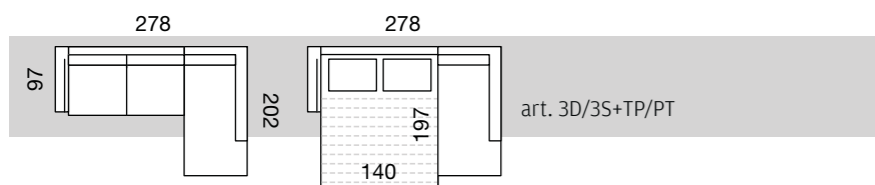

MICK style

Ogni colore si conosce meglio nel suo contrario che nel suo simile...

Colours are best known through their opposites than through their equivalents...

Une couleur se reconnaît mieux dans son contraire que dans son semblable...

Leonardo da Vinci

IL DIVANO LETTO PER SPAZI GIOVANI

La possibilità di un comodo divano letto, anche negli spazi contenuti di un living giovane e informale. Questo è Mick.

THE SOFA BED FOR YOUNG SPACES

The possibility of a comfortable sofa bed, even in the limited space of a young and casual living. This is Mick.

LE CANAPÉ-LIT POUR LES AMBIANCES JEUNES

La possibilité d'un canapé-lit confortable, également dans les espaces restreints d'un salon jeune et informel. Voici Mick.

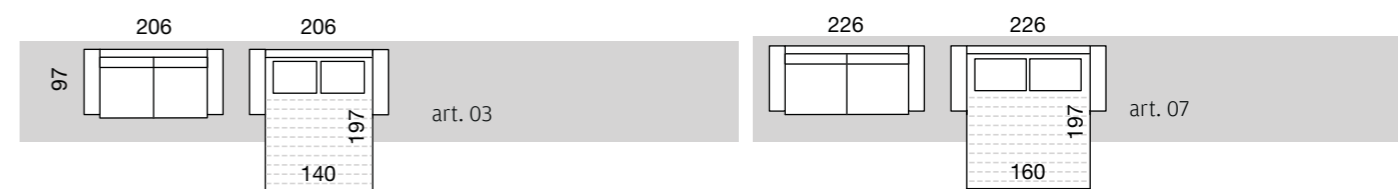



LA POSIZIONE PERFETTA

Mick è un divano letto davvero confortevole. Puoi scegliere di avere lo schienale dotato di meccanismo con cricchetto così da assicurarti un relax ottimale. Perfetto come divano da utilizzare quotidianamente che però all'occorrenza si trasforma in un soffice letto per i tuoi ospiti.

THE PERFECT POSITION

Mick is a really comfortable sofa bed. You can choose a backrest with the ratchet mechanism so as to ensure an optimal relaxation. A perfect sofa for everyday use, but it can also be turned into a soft bed for your guests.

LA POSITION PARFAITE

Mick est un canapé-lit très confortable. Vous pouvez également choisir l'option de dossier avec mécanisme à cliquet permettant de garantir une relaxation optimale. Parfait pour une utilisation quotidienne en tant que canapé, mais qui peut, le cas échéant, être transformé en un lit douillet pour vos invités.

Optional cricchetto

Optional ratchet movement

Moviment à cliquet en option

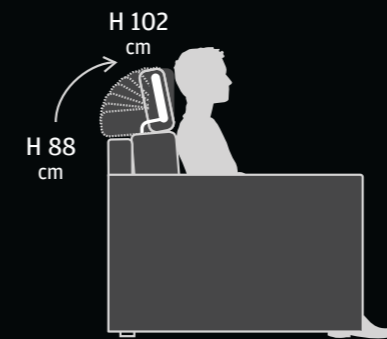

GEOMETRIA DELLE FORME

Forme squadrate, geometriche... il designer deve imparare ad avventurarsi sui sentieri meno battuti della geometria ed a guardare in maniera diversa all'universo di forme che attraversano il nostro sguardo tutti i giorni.

GEOMETRY OF FORMS

Square and geometric shapes... the designer must learn to venture out on the less beaten paths of geometry and look at the universe of forms that cross our eyes every day, in a different way.

GÉOMÉTRIE DES FORMES

Des formes carrées, géométriques... le designer doit apprendre à s'aventurer sur les sentiers moins battus de la géométrie et regarder sous un œil nouveau, l'univers des formes qui croisent notre regard tous les jours.

Disponibile anche in versione fissa

Also available in the fixed version

Également disponible en version fixe

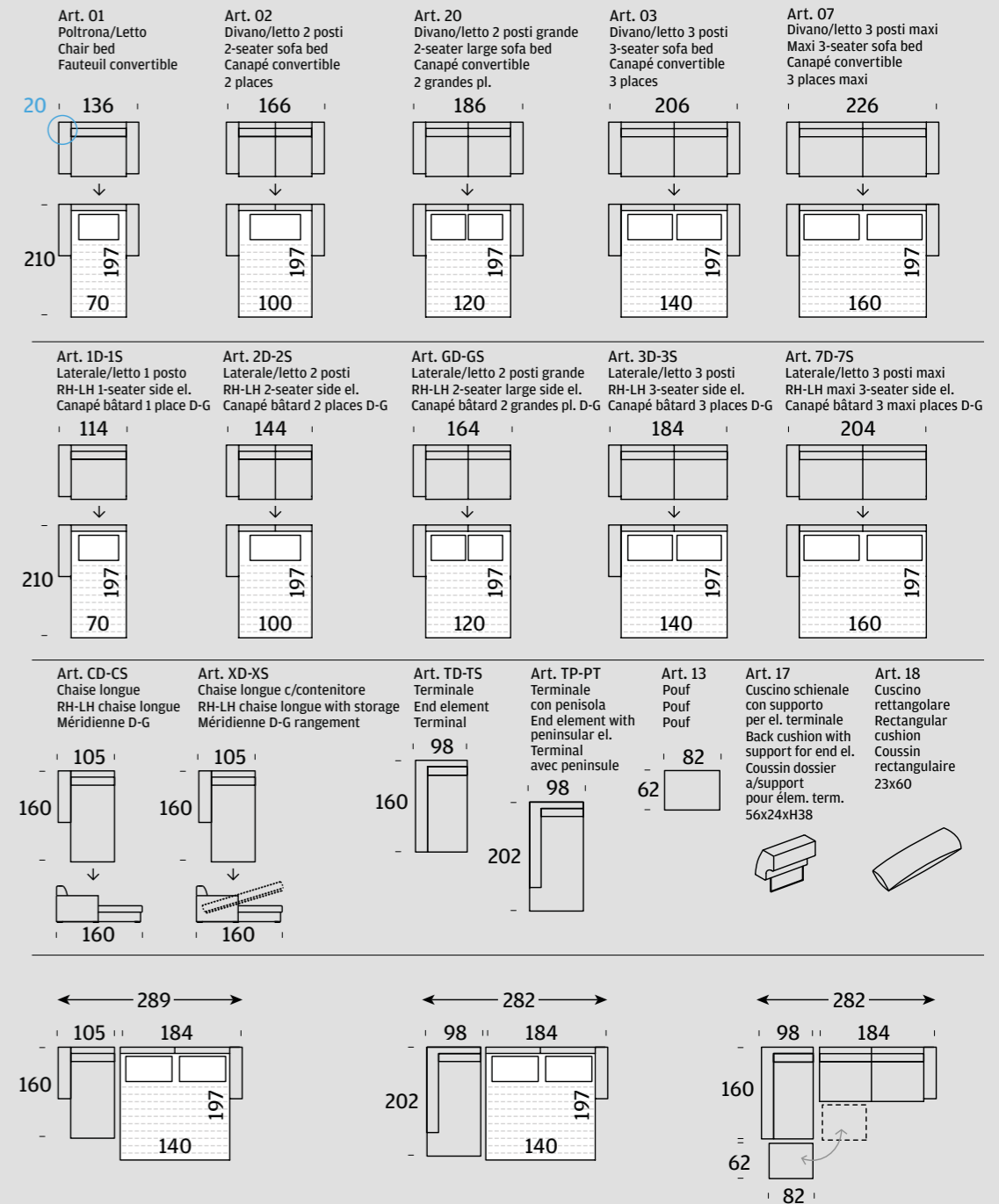
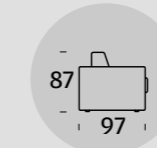

TOM style

PERFETTO OVUNQUE

Tom è il divano letto ideale quando lo spazio in casa non è generoso ma può capitare un ospite inatteso, oppure quando si vive in un monolocale. Questo divano trasformabile risolve l'esigenza di un letto aggiuntivo.

PERFECT EVERYWHERE

Tom is the ideal sofa bed when there isn't much room available in the house but an unexpected guest shows up, or even when you live in a studio apartment. This sofa satisfies the need for an additional bed.

PARFAIT N'IMPORTE OÙ

Tom est le canapé-lit idéal lorsque l'espace de la maison est peu généreux mais susceptible, parfois, d'accueillir un invité inattendu, ou encore si vous vivez dans un studio. Ce canapé convertible résout le besoin d'un lit supplémentaire.



La natura imita ciò che l'opera d'arte le propone.

Nature imitates what the artwork offers.

La nature imite ce que l'œuvre d'art lui propose.

Oscar Wilde

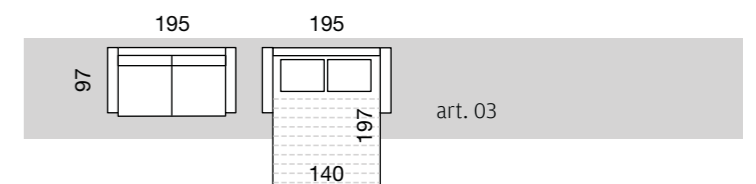

TONI NATURALI

Appreziate la semplicità che si ottiene dai colori neutri, si adattano ad ogni stanza, in particolare alla zona living, in quanto trasmettono un senso di tranquillità ed equilibrio.

NATURAL TONES

Enjoy the simplicity given by neutral colours, which fit every room, especially the living area, as they convey a sense of tranquillity and balance.

TONS NATURELS

Appréciez la simplicité pouvant être obtenue par des tons neutres. Ils s'adaptent à toutes les pièces, notamment le salon, car ils transmettent un sentiment de tranquillité et d'équilibre.



Optional cricchetto

Optional ratchet movement

Moviment à cliquet en option

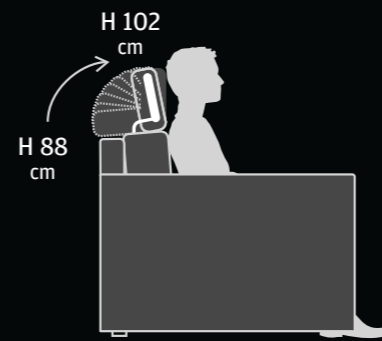

Disponibile anche in versione fissa

Also available in the fixed version

Également disponible en version fixe

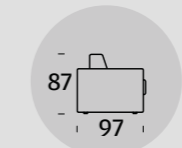

Art. 01 Poltrona/Letto Chair bed Fauteuil convertible	Art. 02 Divano/letto 2 posti 2-seater sofa bed Canapé convertible 2 places	Art. 20 Divano/letto 2 posti grande 2-seater large sofa bed Canapé convertible 2 grandes pl.	Art. 03 Divano/letto 3 posti 3-seater sofa bed Canapé convertible 3 places	Art. 07 Divano/letto 3 posti maxi Maxi 3-seater sofa bed Canapé convertible 3 places maxi		
15 125 210 197 70	155 197 100	175 197 120	195 197 140	215 197 160		
Art. 1D-1S Laterale/letto 1 posto RH-LH 1-seater side el. Canapé bâlard 1 place D-G	Art. 2D-2S Laterale/letto 2 posti RH-LH 2-seater side el. Canapé bâlard 2 places D-G	Art. GD-GS Laterale/letto 2 posti grande RH-LH 2-seater large side el. Canapé bâlard 2 grandes pl. D-G	Art. 3D-3S Laterale/letto 3 posti RH-LH 3-seater side el. Canapé bâlard 3 places D-G	Art. 7D-7S Laterale/letto 3 posti maxi RH-LH maxi 3-seater side el. Canapé bâlard 3 maxi places D-G		
108 210 197 70	138 197 100	158 197 120	178 197 140	198 197 160		
Art. CD-CS Chaise longue RH-LH chaise longue Méristenne D-G	Art. XD-XS Chaise longue c/contenitore RH-LH chaise longue with storage Méristenne D-G rangement	Art. TD-TS Terminale End element Terminal	Art. TP-PT Terminale con penisola End element with peninsular el. Terminal avec peninsule	Art. 13 Pouf Pouf Pouf	Art. 17 Cuscino schienale con supporto per el. terminale Back cushion with support for end el. Cousin dossier a/support pour elem. term. 56x24xH38	Art. 18 Cuscino rettangolare Rectangular cushion Cousin rectangulaire 23x60
100 100 160 160 160 160	100 100 160 160 160 160	98 202	98 202	82 62	62 56x24xH38	62 23x60
278 100 178 160 197 140		276 98 178 202 197 140		276 98 178 160 197 62 82		

INTERNO-ESTERNO

Lascia che interno ed esterno comunichino tra di loro. Ampie vetrate dalle quali godere del paesaggio amplificheranno il tuo senso di benessere.

INTERIOR-EXTERIOR

Let the interior and exterior communicate with each other. Large windows from which to enjoy the landscape will boost your sense of well-being.

INTERNE-EXTERNE

Laissez l'intérieur et l'extérieur communiquer entre eux. De grandes baies vitrées pour profiter du paysage stimulent votre sentiment de bien-être.

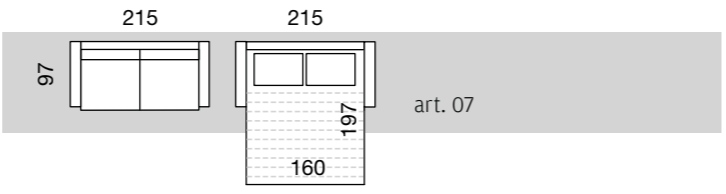

STEVE style

Siamo fatti della stessa sostanza dei sogni.

We are such stuff as dreams are made on.

Nous sommes faits de la même étoffe que les rêves.

William Shakespeare

IL DIVANO LETTO DA VIVERE

Appena sveglio, prenditi dieci minuti per "creare" la giornata che andrai a vivere. Distenditi su Steve e rilassati: ti aiuterà a dare una direzione positiva a quello che andrai a vivere.

THE SOFA TO BE LIVED

As soon as you wake up, take ten minutes to "create" the day you're going to live. Lie on Steve and relax: it will help you give a positive direction to what you're going to live.

LE CANAPÉ-LIT À VIVRE

À peine réveillé, prenez dix minutes pour « créer » la journée que vous allez vivre. Allongez-vous sur Steve et détendez-vous : il vous aidera à donner un sens positif à ce que vous allez vivre.

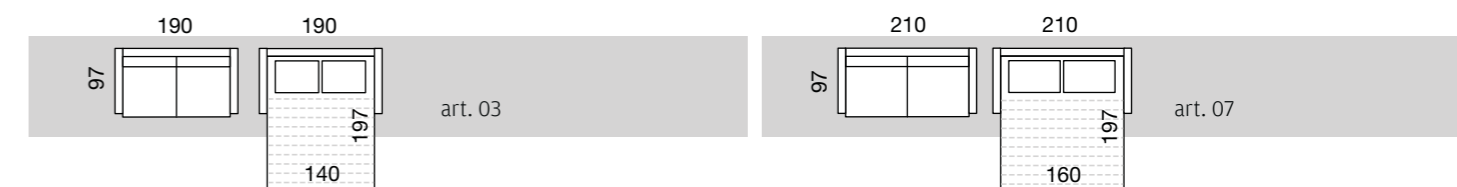

SOFT TREND

UN TOCCO DI DELICATEZZA

Il color avorio e il panna sono entrambi versatili come il bianco, ma risultano più morbidi e meno freddi, donando all'ambiente un tocco di delicatezza.

A GENTLE TOUCH

Ivory and cream colours are both as versatile as white, but they are softer and less cold, giving the room a touch of delicacy.

UNE TOUCHE DE DÉLICATESSE

L'ivoire et le crème sont aussi versatiles que le blanc, mais ils sont plus doux et moins froids, pour conférer à la pièce une touche de délicatesse.



Optional cricchetto

Optional ratchet movement

Moviment à cliquet en option

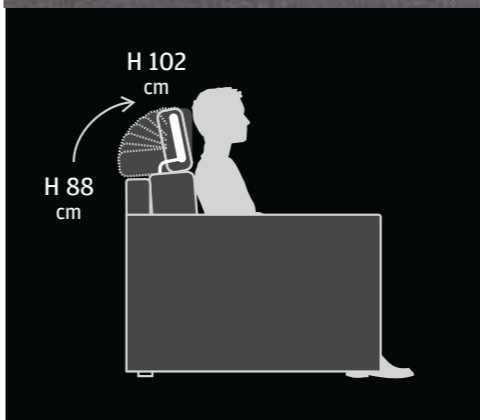

NON SOLO PER IL LIVING

Un divano letto adatto anche per ambienti diversi dal living come un ufficio od uno studio. Ideale per accogliere e per rappresentanza.

NOT ONLY FOR THE LIVING AREA

A sofa bed is also suitable for different environments from the living room, such as an office or a studio. Ideal for accommodation and representation.

PAS SEULEMENT POUR LE SALON

Un canapé-lit également adapté pour les espaces autres que le salon comme le bureau. Idéal pour héberger et dans un contexte de représentation.

Disponibile anche in versione fissa

Also available in the fixed version

Également disponible en version fixe

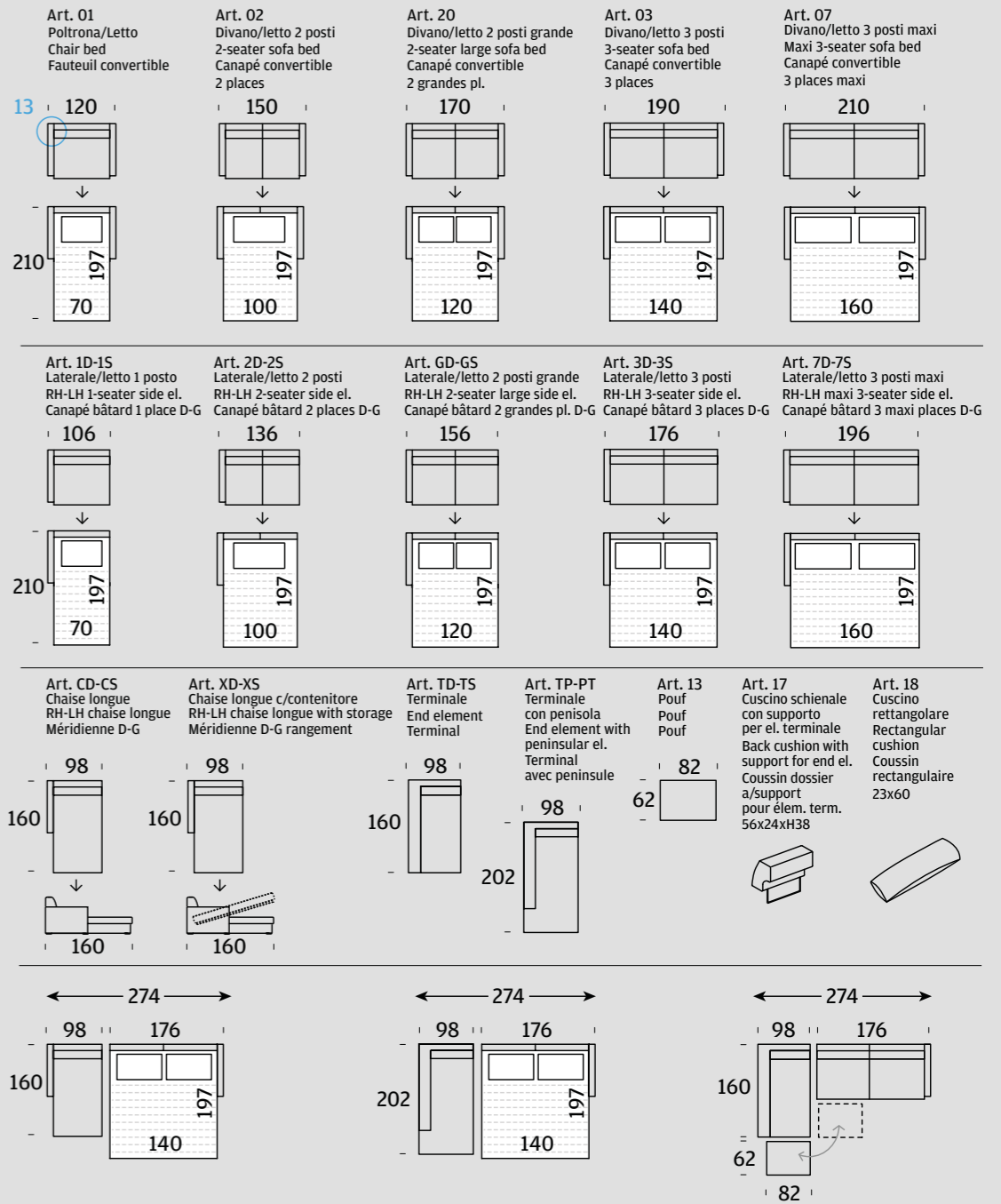
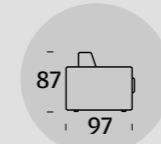

MARK style

IL DIVANO LETTO CHE DESIDERI

Mark divano letto componibile coordinabile con penisole e pouf, dotato di meccanica servoassistita, apertura semplificata mediante la rotazione dello schienale, sfoderabilità totale.

THE SOFA BED YOU DESIRE

Mark is a modular sofa bed, to be paired with peninsulas and pouf, it has a power assisted mechanism, an opening simplified by rotating the back, completely removable covers.

LE CANAPÉ-LIT QUE VOUS DÉSIREZ

Mark est le canapé-lit modulaire, pouvant être coordonné avec des péninsules et des poufs, Jim est doté d'un système mécanique à commande assistée et d'une ouverture simplifiée par simple rotation du dossier, entièrement déhoussable.



*Dimmi con chi dormi
e ti dirò chi sogni.*

*Tell me whom you sleep with
and I shall tell you whom you
dream of.*

*Dites-moi avec qui vous dormez,
je vous dirai à qui vous rêvez.*

Stanisław J. Lec

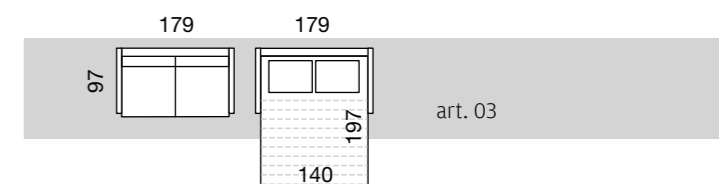

OGGETTO DI DESIGN

Moderno con i suoi braccioli sottilissimi sembra quasi un oggetto di design. Davvero confortevole e pratico.

A DESIGN OBJECT

So modern with his ultra-thin arms, it almost looks like a design object. Really comfortable and practical.

OBJET DESIGN

Moderne avec ses accoudoirs ultra-minces, il ressemble presque à un objet de design. Véritablement confortable et pratique.



Optional cricchetto

Optional ratchet movement

Moviment à cliquet en option

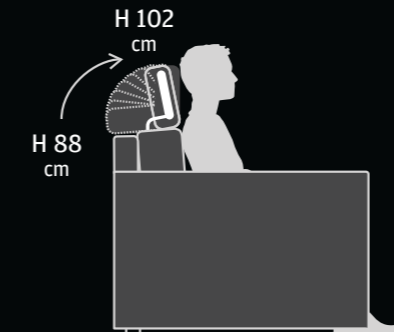

ARTE SULLE PARETI

L'arredamento di casa non è completo senza i quadri alle pareti. Con un quadro si può rendere il living una stanza più calda e accogliente, e dare quel tocco in più che personalizza.

ART ON THE WALLS

The interior of the house is not complete without pictures on the walls. A painting can make a living room look warmer and more welcoming, as well as give it a personalized touch.

DE L'ART SUR LES MURS

L'ameublement de la maison n'est pas complet sans quelques cadres sur les murs. Un cadre peut rendre le salon plus chaleureux et accueillant, avec une touche de personnalité en plus.

Disponibile anche in versione fissa

Also available in the fixed version

Également disponible en version fixe

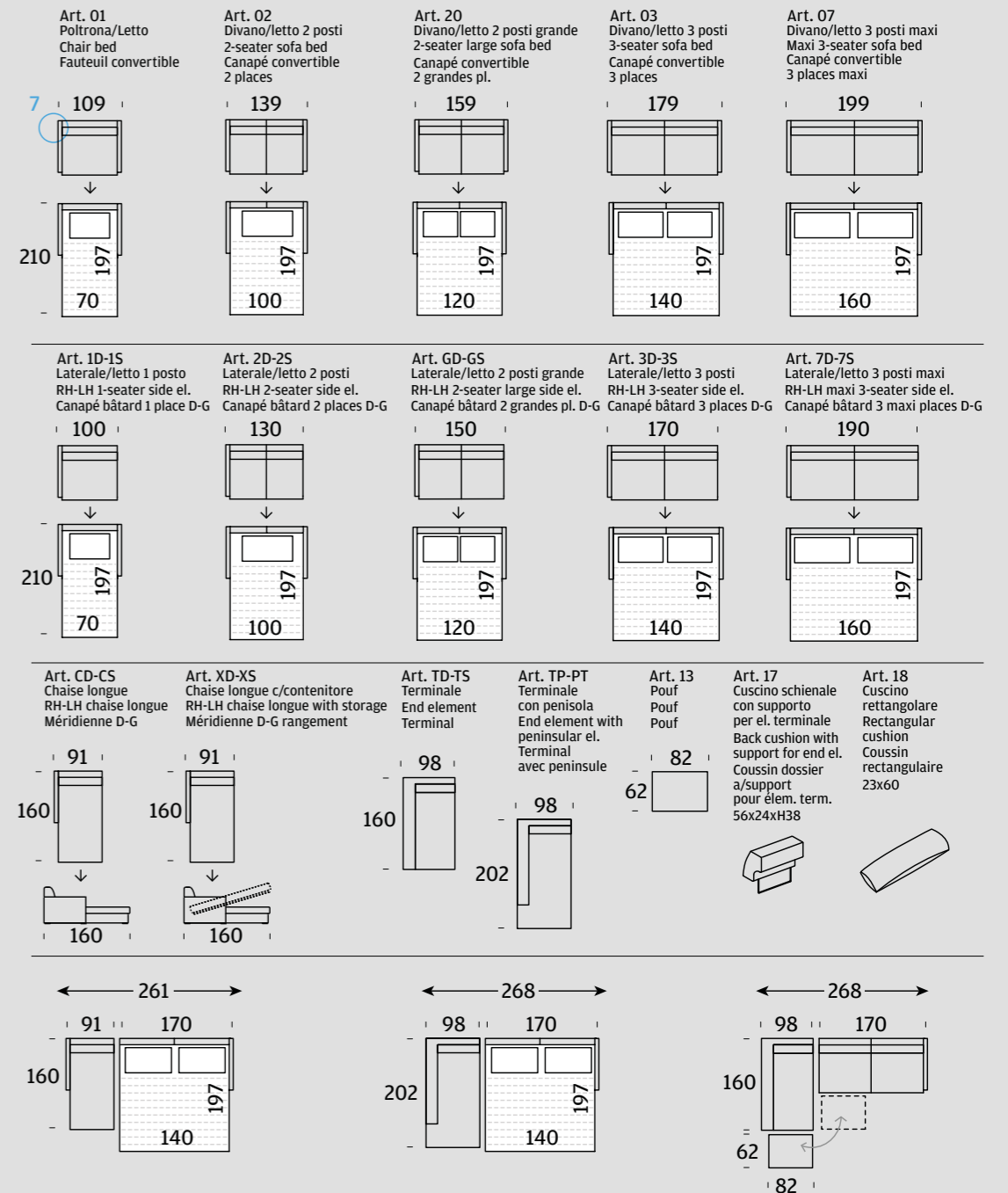
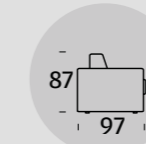

BOB style

Il sonno, e tutto ciò che induce il sonno, è di per se stesso piacevole.

Sleep, and everything that induces sleep, is in itself pleasant.

Le sommeil, et tout ce qui entoure le sommeil, sont par nature agréables.

Giacomo Leopardi

CALDA COMODITA'

Un divano letto che ti permette di fare sonni davvero tranquilli. Pratico, confortevole è coordinabile con pouf che a piacimento si possono accostare al divano per ottenere, all'occorrenza, un posto in più.

WARM COMFORT

A sofa bed that allows you to really sleep soundly. Practical and comfortable, it can be paired with poufs that can be matched with the sofa at will, in order to obtain, where appropriate, an extra seat.

CONFORT CHALEUREUX

Un canapé-lit qui vous permet de dormir en toute tranquillité.

Pratique et confortable, il peut être coordonné avec des poufs à combiner à volonté au canapé, et disposer, le cas échéant, d'une place supplémentaire.

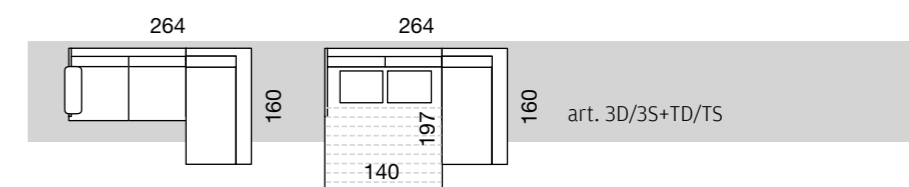

FACILE PRATICO BELLO

Quando di spazio a disposizione c'è né davvero poco, allora Bob è la risposta giusta. I suoi cuscini sono facilmente staccabili, le sue forme contenute lo rendono perfetto per essere inserito in una struttura a ponte. Divano di giorno, letto di notte. E puoi dormire sonni tranquilli.

EASY PRACTICAL BEAUTIFUL

When the space available is very little, Bob is the right answer. Its cushions are easily removable, its contained forms make it perfect to be placed in a bridge structure. Sofa by day, bed at night. And you can sleep soundly.

FACILE PRATIQUE BEAU

Lorsque l'espace à disposition est vraiment très restreint, Bob s'impose comme une réponse. Ses coussins sont facilement décrochables, ses formes contenues le rendent parfait pour une insertion dans une structure en pont. Canapé le jour, lit la nuit. Pour dormir en toute tranquillité.

Personalizzabile
come vuoi tu!

Customizable as
you want!

Personnalisable à
souhait !



Stacca il cuscino per guadagnare spazio o per trasformare Bob in un divano letto minimale e funzionale.

Remove the cushion to save space or to turn Bob into a minimalist and functional sofa bed.

Décrochez le coussin pour économiser de l'espace ou pour transformer Bob en un canapé-lit minimaliste et fonctionnel.

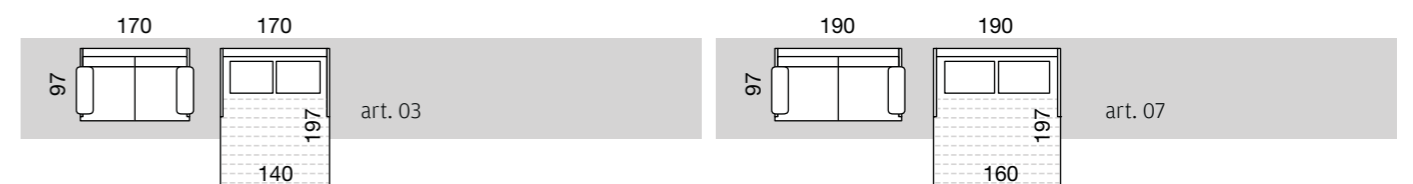



PER UNO SPAZIO GIOVANE

Il divano letto Bob risolve con pochi gesti i problemi di ospitalità a casa! Perfetto anche in appartamenti giovani, può essere utilizzato anche come letto principale.

FOR A YOUNG SPACE

The Bob sofa bed solves problems of hospitality at home with a few gestures! Also perfect for young people's apartments, it can also be used as the main bed.

UN ESPACE POUR LES JEUNES

Le canapé-lit Bob permet de résoudre en quelques gestes les problèmes d'hospitalité à la maison ! Parfait également dans les appartements jeunes, il peut être utilisé comme lit principal.

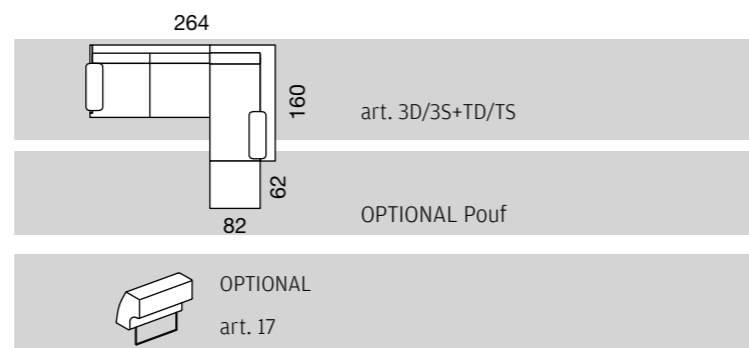

Optional cricchetto

Optional ratchet movement

Moviment à cliquet en option

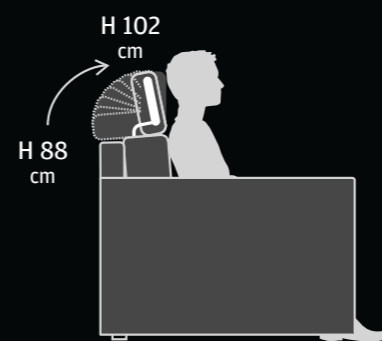

Disponibile anche in versione fissa

Also available in the fixed version

Également disponible en version fixe

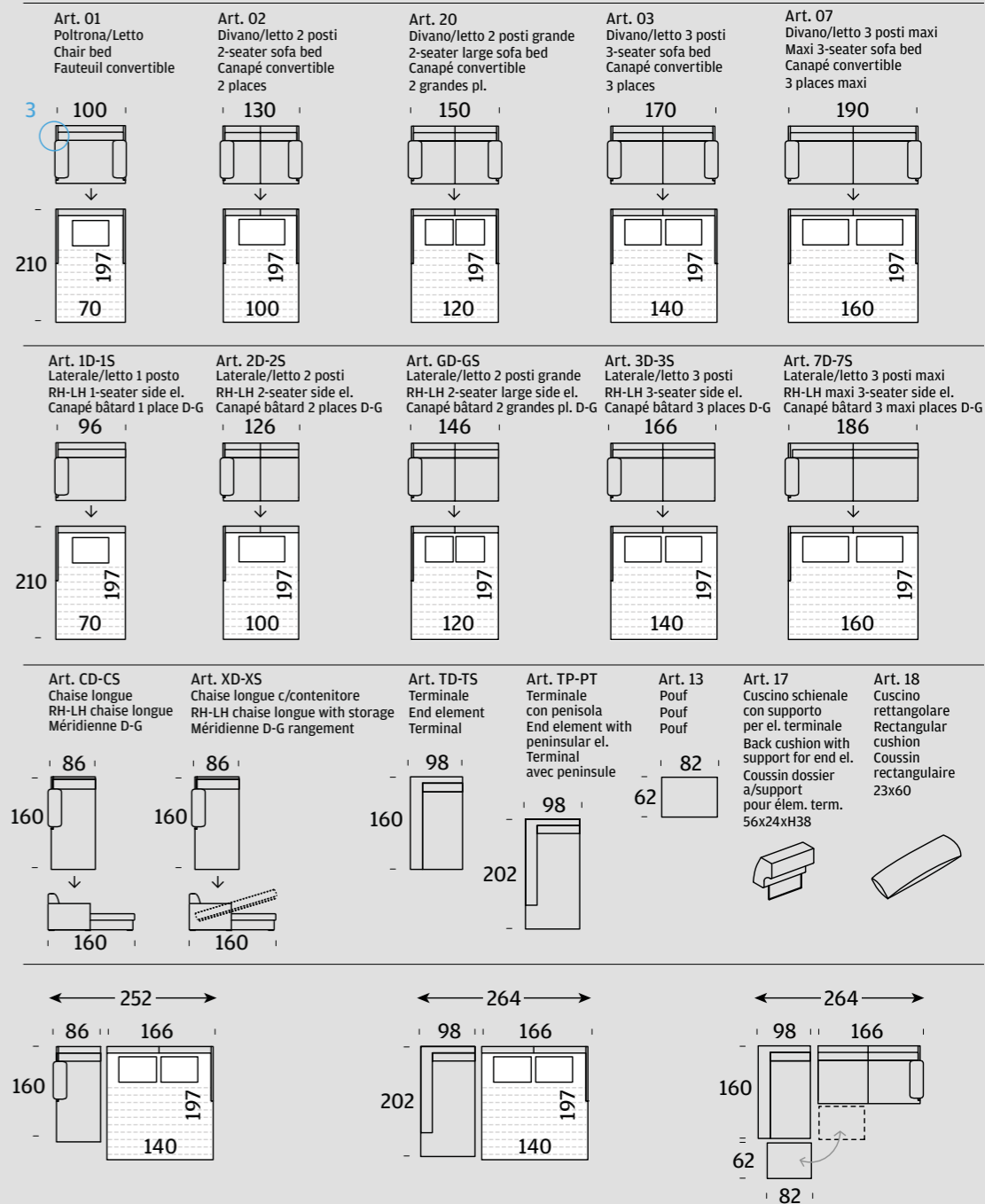
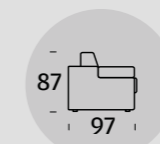

DOPPIA FUNZIONALITÀ

Scegliere un divano letto vuol dire doppia funzionalità ma senza rinunciare alle regole fondamentali del buon riposo e del benessere.

DUAL FUNCTIONALITY

Choosing a sofa bed means dual functionality without sacrificing the fundamental rules of good rest and well-being.

DOUBLE FONCTION

Choisissez un canapé-lit signifie demander une double fonction sans sacrifier les règles fondamentales du sommeil réparateur et du bien-être.

SVEN style

Se puoi sognarlo, puoi farlo.

If you can dream it, you can do it.

Si vous pouvez le rêver, vous pouvez le faire. - Walt Disney

DEDICATO AI SOGNATORI

Dedicato alle case dei viaggiatori, ma anche a chi ama viaggiare con la mente o grazie ad un buon libro. Sven è un divano che ti permette di sognare mete lontane.

DEDICATED TO DREAMERS

Dedicated to the homes of travellers, but also to those who love to travel with their fantasy or with the help of a good book. Sven is a sofa bed that allows you to dream of distant destinations.

DÉDIÉ AUX RÊVEURS

Consacré aux maisons de voyageurs, mais également à qui aime voyager avec l'esprit ou avec un bon livre. Sven est un canapé qui vous permet de rêver de destinations lointaines.

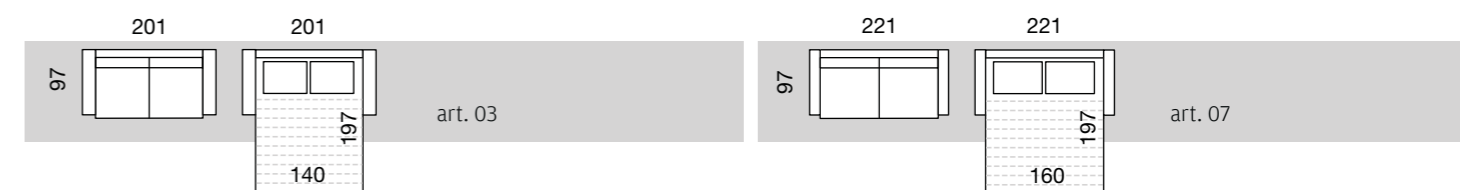

Il viaggio è nella testa.

Travel is in the head.

Le voyage est dans la tête.

Jean Baudrillard

DIVANO TRASFORMISTA

Più di un divano, un divano letto.

E per aumentare ancora il comfort è disponibile un meccanismo a cricchetto che permette di spostare lo schienale in 15 posizioni rilassanti.

A TRANSFORMER SOFA

More than a sofa, a sofa bed.

For added comfort there is a ratchet mechanism that allows you to move the backrest in 15 relaxing positions.

CANAPÉ TRANSFORMISTE

Plus qu'un canapé, un canapé-lit.

Pour encore plus de confort, un mécanisme de cliquet est disponible pour rabattre le dossier en 15 positions de détente.



Optional cricchetto

Optional ratchet movement

Moviment à cliquet en option

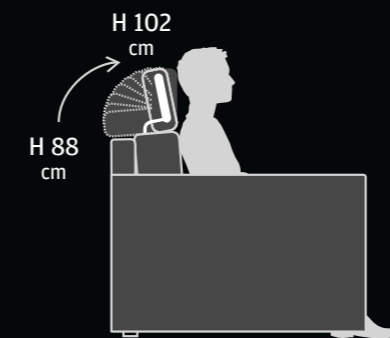

IL DESIGN COMODO

Non solo il divano letto è una soluzione comoda, molto pratica e utile, ma oggi è anche un elemento di design davvero molto elegante e semplice. Come Sven il divano letto dotato di apertura semplificata mediante la rotazione dello schienale e completamente sfoderabile.

COMFORTABLE DESIGN

Not only sofa beds are a convenient, very practical and useful, but today they are also very elegant and simple design elements. Like Sven, the sofa bed with a simplified opening by rotation of the back, completely removable covers.

LE DESIGN PRATIQUE

Non seulement le canapé-lit est une solution commode, très pratique et utile, mais également aujourd'hui, un élément de design très élégant et simple. Comme Sven, le canapé-lit doté d'un système d'ouverture simplifiée par rotation du dossier et complètement déhoussable.

Disponibile anche in versione fissa

Also available in the fixed version

Également disponible en version fixe

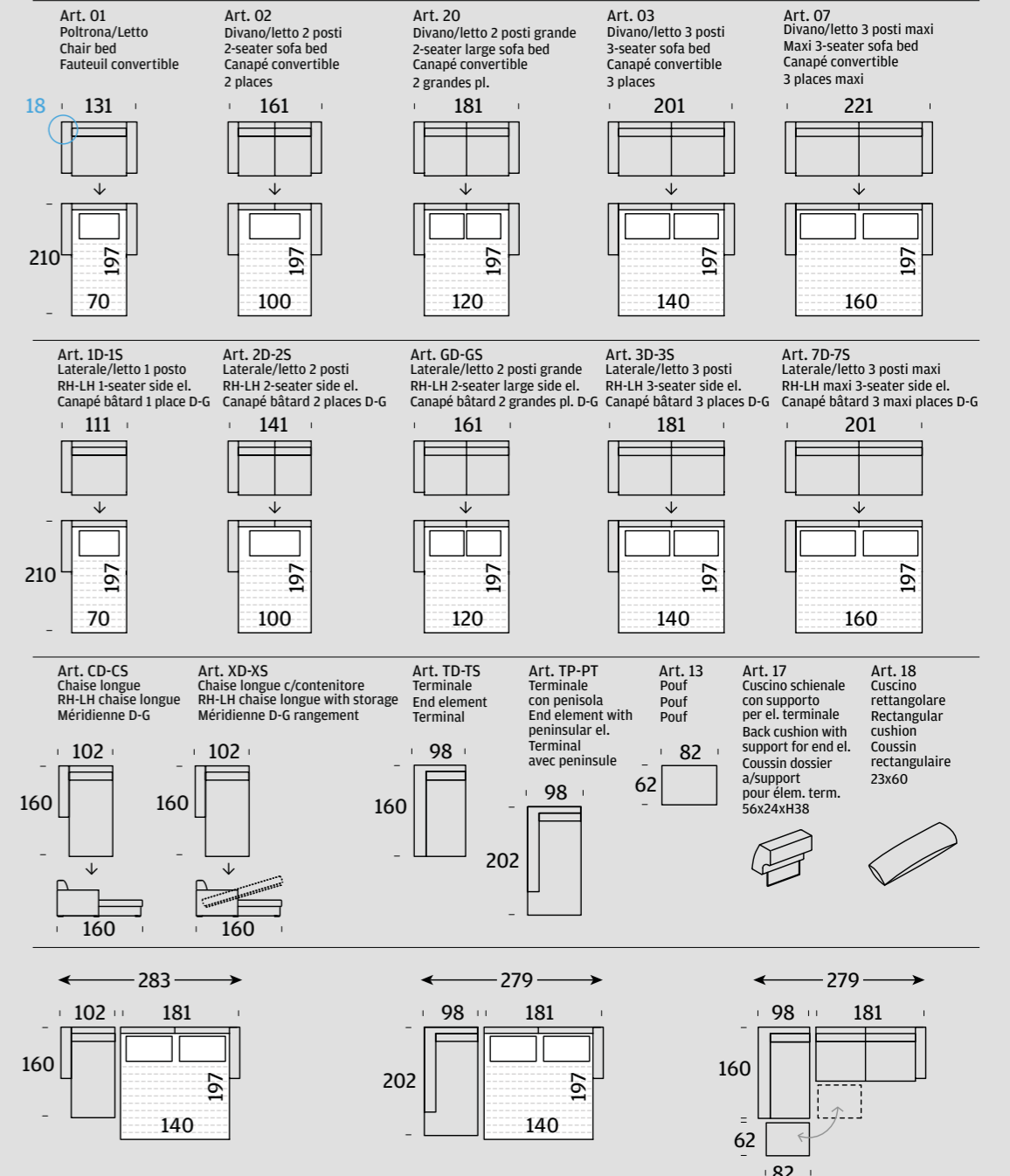
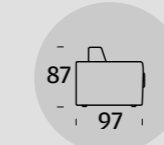

GRACE style

IL LETTO IN PIÙ

A tutti piace avere la possibilità di ospitare amici e persone care nella propria casa. Ma spesso le metrature limitate delle abitazioni non lo permettono. In questi casi ti viene in aiuto un divano letto come Grace con apertura semplificata mediante la rotazione dello schienale, completamente sfoderabile.

THE EXTRA BED

Everyone likes to be able to host friends and loved ones at home. But often, a limited size house does not allow it. In situations like these, a sofa bed like Grace comes to your aid with a simplified opening by rotating the back, completely removable covers.

LE LIT EN PLUS

Tout le monde aime avoir la possibilité d'accueillir amis et proches à la maison. Mais souvent les dimensions restreintes des logements ne le permettent pas. Dans ce cas, c'est le canapé-lit Grace qui viendra à votre secours avec son système d'ouverture simplifiée par rotation du dossier et complètement déhoussable.



Spazio, luce, ordine. Sono cose di cui gli uomini hanno bisogno, come hanno bisogno di pane o di un posto per dormire.

Space and light and order. Those are the things that men need just as much as they need bread or a place to sleep.

Espace, lumière, ordre. Ce sont des choses dont les hommes ont besoin, comme ils ont besoin de pain ou d'un endroit où dormir.

Le Corbusier

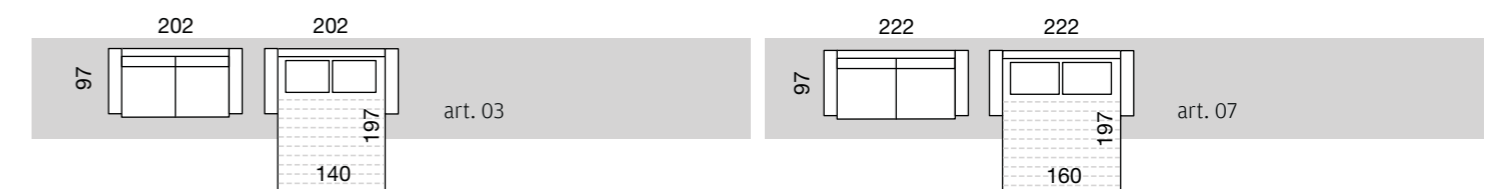

NEW CLASSIC

Avvolgente per un riposo che si fa classico, ma in modo nuovo, sorprendente. La grazia è ben delineata dalla forma sinuosa del bracciolo, pensato per sostenerti con classe.

NEW CLASSIC

Enveloping for a classic way of resting which becomes new, surprising. Its grace is well-defined by the sinuous shape of the armrest, designed to support you with style.

NEW CLASSIC

Enveloppant pour un repos aux notes classiques, mais dans un esprit nouveau, surprenant. La grâce est bien délimitée par la forme sinueuse de l'accoudoir, conçu pour vous fournir un appui de classe.



Optional cricchetto

Optional ratchet movement

Moviment à cliquet en option

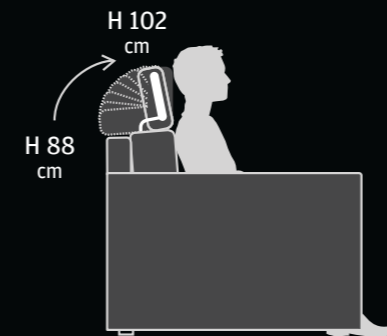

GRAZIA FRANCESE

Una casa romantica, con tanti libri di poeti francesi in bella mostra. Ecco come arredare casa in stile francese. Il parquet è d'obbligo così come i colori pastello. Cuscini, pizzi e merletti per richiamare il romanticismo di fine '800.

FRENCH GRACE

A romantic house, with many books of French poets on display. Here's how to decorate a house in French style. The parquet is a must, as well as pastel colours. Pillows and lace, to invoke the romance of the late nineteenth century.

LA GRÂCE FRANÇAISE

Une maison romantique, avec de nombreux livres de poètes français en exposition. Voici comment décorer la maison dans un style français. Le parquet est un must, tout comme les couleurs pastel. Coussins, dentelles et crochets pour invoquer le romantisme de la fin du 19ème siècle.

Disponibile anche in versione fissa

Also available in the fixed version

Également disponible en version fixe

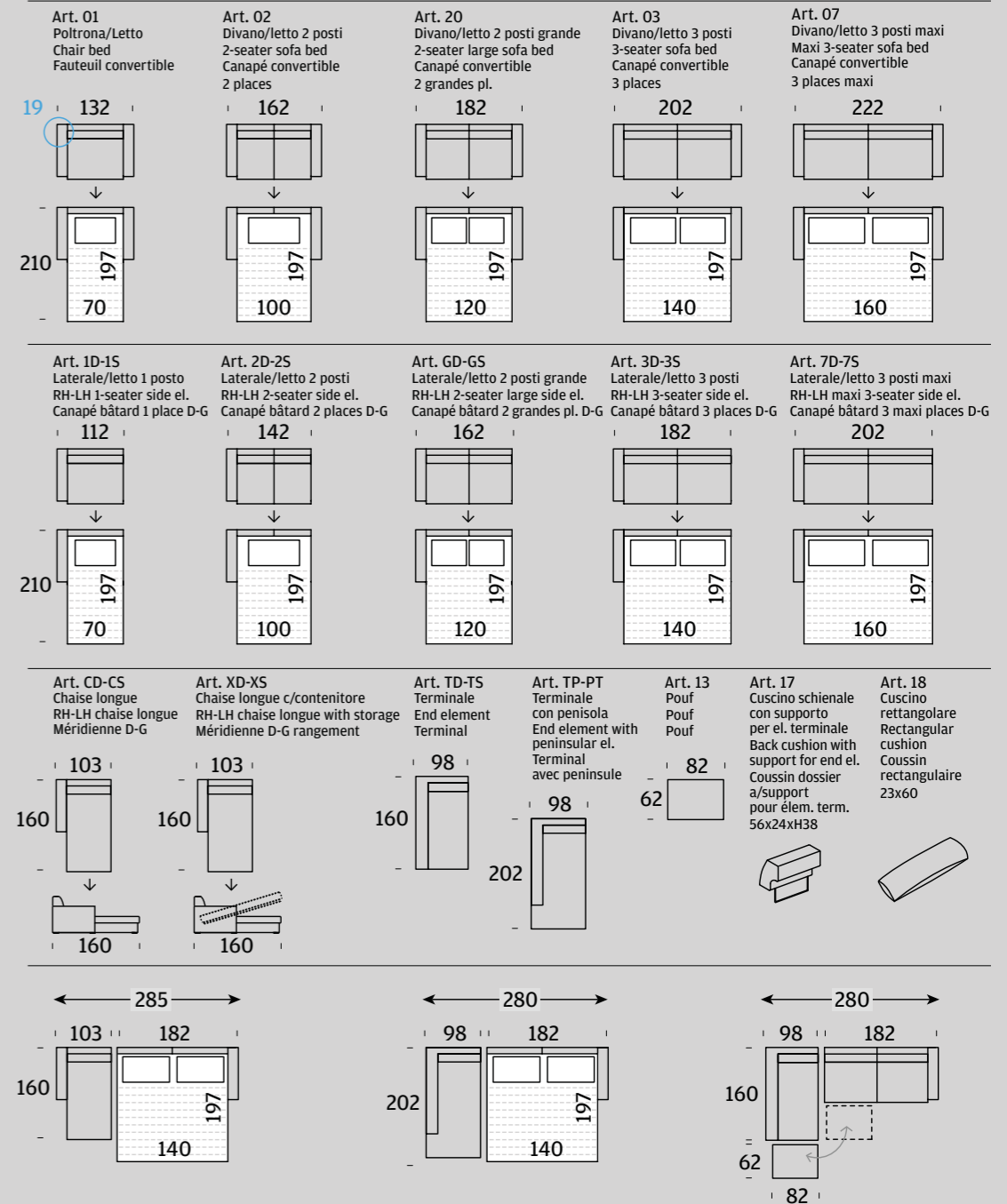
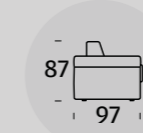

JANIS style

Sognatore è un uomo con i piedi fortemente appoggiati sulle nuvole.

A dreamer is a man with his feet flat on the clouds.

Un rêveur est un homme dont les pieds sont fermement ancrés dans les nuages.

Ennio Flaiano

CLASSICO CON GUSTO

Un divano con braccioli rotondi plissettati e schienale dai bordi stondati. Perfetto per ambientazioni liberty, per case di campagna ma anche per storici appartamenti cittadini.

CLASSIC WITH TASTE

A sofa with folded round armrests and a backrest with rounded edges. Perfect for liberty environments, country houses, but also historical city apartments.

LE CLASSIQUE AVEC GOÛT

Un canapé avec des accoudoirs ronds plissés et un dossier aux bords arrondis. Parfait pour les ambiances liberty, pour les maisons de campagne et les appartements historiques en ville.

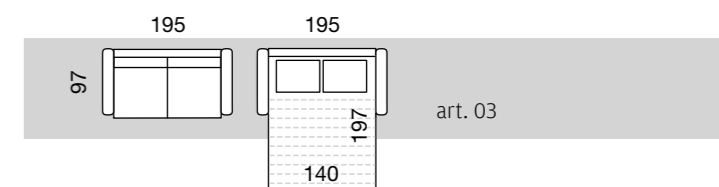



Grazie al meccanismo con rotazione dello schienale è facile e veloce passare dal divano al letto e viceversa.

The rotation mechanism of the back makes it fast and easy to switch from the sofa to the bed and vice versa.

Grâce au mécanisme avec rotation du dossier, passer du canapé au lit, ou inversement, est facile et rapide.

Optional cricchetto
Optional ratchet movement
Mouvement à cliquet en option

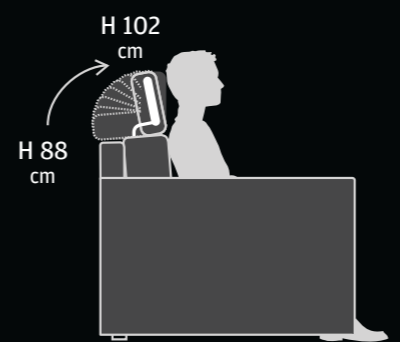

SOGGIORNO FUNZIONALE

La zona giorno, è il cuore pulsante di ogni casa. Progetta questo ambiente in maniera funzionale ed accogliente.

Grazie al divano letto Janis potrai anche accogliere i tuoi ospiti.

A FUNCTIONAL LIVING-ROOM

The living area is the heart of any home. Design this environment in a functional and welcoming way.

Thanks to Janis sofa bed, you can also accommodate your guests.

SÉJOUR FONCTIONNEL

Le salon est le cœur de la maison. Concevez cet espace de manière fonctionnelle et accueillante.

Grâce au canapé-lit Janis, vous pourrez également accueillir vos invités.

Disponibile anche in versione fissa
Also available in the fixed version
Également disponible en version fixe

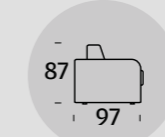

<p>Art. 01 Poltrona/Letto Chair bed Fauteuil convertible</p> <p>15 125 210 70</p>	<p>Art. 02 Divano/letto 2 posti 2-seater sofa bed Canapé convertible 2 places</p> <p>155 197 100</p>	<p>Art. 20 Divano/letto 2 posti grande 2-seater large sofa bed Canapé convertible 2 grandes pl.</p> <p>175 197 120</p>	<p>Art. 03 Divano/letto 3 posti 3-seater sofa bed Canapé convertible 3 places</p> <p>195 197 140</p>	<p>Art. 07 Divano/letto 3 posti maxi Maxi 3-seater sofa bed Canapé convertible 3 places maxi</p> <p>215 197 160</p>		
<p>Art. 1D-1S Laterale/letto 1 posto RH-LH 1-seater side el. Canapé bâtarde 1 place D-G</p> <p>108 197 70</p>	<p>Art. 2D-2S Laterale/letto 2 posti RH-LH 2-seater side el. Canapé bâtarde 2 places D-G</p> <p>138 197 100</p>	<p>Art. GD-GS Laterale/letto 2 posti grande RH-LH 2-seater large side el. Canapé bâtarde 2 grandes pl. D-G</p> <p>158 197 120</p>	<p>Art. 3D-3S Laterale/letto 3 posti RH-LH 3-seater side el. Canapé bâtarde 3 places D-G</p> <p>178 197 140</p>	<p>Art. 7D-7S Laterale/letto 3 posti maxi RH-LH maxi 3-seater side el. Canapé bâtarde 3 maxi places D-G</p> <p>198 197 160</p>		
<p>Art. CD-CS Chaise longue RH-LH chaise longue Mériidienne D-G</p> <p>100 160 160</p>	<p>Art. XD-XS Chaise longue c/contentitore RH-LH chaise longue with storage Mériidienne D-G rangement</p> <p>100 160 160</p>	<p>Art. TD-TS Terminale End element Terminal</p> <p>98 160 202</p>	<p>Art. TP-PT Terminale con penisola End element with peninsular el. Terminal avec peninsule</p> <p>98 160 202</p>	<p>Art. 13 Pouf Pouf</p> <p>82 62</p>	<p>Art. 17 Cuscino schienale con supporto per el. terminale Back cushion with support for end el. Cousin dossier a/support pour elem. term. 56x24xH38</p> <p>62 82</p>	<p>Art. 18 Cuscino rettangolare Rectangular cushion Cousin rectangulaire 23x60</p> <p>62 82</p>
<p>278 100 178 160 197 140</p>		<p>276 98 178 202 197 140</p>		<p>276 98 178 160 197 62 82</p>		

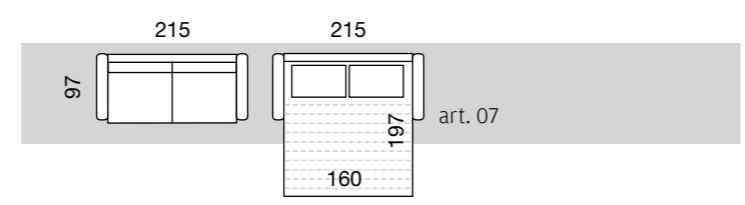

JOHN style

La vita ed i sogni sono fogli di uno stesso libro.

Life and dreams are pages in the same book.

La vie et les rêves sont les feuilles d'un seul livre. - Arthur Schopenhauer

OSPITALITÀ DI CLASSE

Chiuso arreda con classe, aperto ci permette di aumentare i posti letto! John è il divano letto elegante, completamente sfoderabile.

CLASSY HOSPITALITY

When it's closed, it is a classy piece of furniture; when it's open, it makes it possible to increase the number of beds! John is the stylish sofa bed, with completely removable covers.

L'HOSPITALITÉ AVEC CLASSE

Fermé, il meuble élégamment, ouvert, il permet d'augmenter le nombre de couchage! John est le canapé-lit élégant, entièrement déhoussable.



SINTESI DI STILE

Bello, elegante ma anche confortevole. John è la sintesi perfetta di estetica e comfort.

SYNTHESIS OF STYLE

Beautiful, elegant, but also comfortable. John is the perfect synthesis of aesthetics and comfort.

SYNTHÈSE DE STYLE

Beau, élégant mais également confortable. John est la synthèse parfaite de l'esthétisme et du confort.



Optional cricchetto

Optional ratchet movement

Moviment à cliquet en option

H 102 cm

H 88 cm

CARATTERE URBANO

Una ristrutturazione può essere l'occasione per inserire nella struttura della casa un elemento architettonico originale ma anche funzionale come delle ampie vetrate dalle quali, seduto sul tuo divano letto John, potrai ammirare lo skyline della città.

URBAN CHARACTER

A renovation can be an opportunity to insert an original, but also functional, architectural element into the structure of the house, such as a large set of windows from which you can admire the city skyline, while sitting on your sofa bed John.

CARACTÈRE URBAIN

Une rénovation peut être l'occasion d'insérer un élément architectural original mais également fonctionnel dans la structure de la maison, comme de grandes fenêtres depuis lesquelles, assis dans votre canapé-lit John, vous pourrez admirer les toits de la ville.

Disponibile anche in versione fissa

Also available in the fixed version

Également disponible en version fixe



Art. 01 Poltrona/Letto Chair bed Fauteuil convertible	Art. 02 Divano/letto 2 posti 2-seater sofa bed Canapé convertible 2 places	Art. 20 Divano/letto 2 posti grande 2-seater large sofa bed Canapé convertible 2 grandes pl.	Art. 03 Divano/letto 3 posti 3-seater sofa bed Canapé convertible 3 places	Art. 07 Divano/letto 3 posti maxi Maxi 3-seater sofa bed Canapé convertible 3 places maxi		
13 120 210 70	150 197 100	170 197 120	190 197 140	210 197 160		
Art. 1D-1S Laterale/letto 1 posto RH-LH 1-seater side el. Canapé bâtarde 1 place D-G	Art. 2D-2S Laterale/letto 2 posti RH-LH 2-seater side el. Canapé bâtarde 2 places D-G	Art. GD-GS Laterale/letto 2 posti grande RH-LH 2-seater large side el. Canapé bâtarde 2 grandes pl. D-G	Art. 3D-3S Laterale/letto 3 posti RH-LH 3-seater side el. Canapé bâtarde 3 places D-G	Art. 7D-7S Laterale/letto 3 posti maxi RH-LH maxi 3-seater side el. Canapé bâtarde 3 maxi places D-G		
106 210 70	136 197 100	156 197 120	176 197 140	196 197 160		
Art. CD-CS Chaise longue RH-LH chaise longue Mérienne D-G	Art. XD-XS Chaise longue c/contenitore RH-LH chaise longue with storage Mérienne D-G rangement	Art. TD-TS Terminale End element Terminal	Art. TP-PT Terminale con penisola End element with peninsular el. Terminal avec peninsula	Art. 13 Pouf Pouf Pouf	Art. 17 Cuscino schienale con supporto per el. terminale Back cushion with support for end el. Cousin dossier a/support pour elem. term. 56x24xH38	Art. 18 Cuscino rettangolare Rectangular cushion Cousin rectangulaire 23x60
98 160 160	98 160 160	98 160 202	98 160 202	82 62		
274 98 176 160 140	274 98 176 160 140	274 98 176 160 140	274 98 176 160 140	274 98 176 160 62 82		



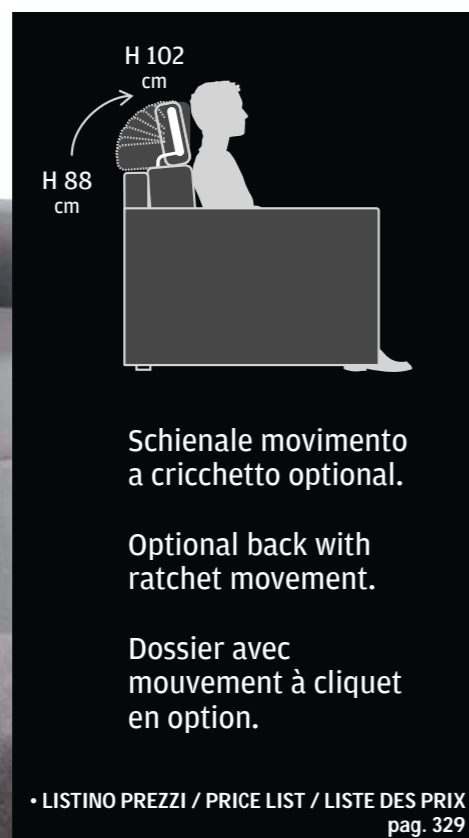

Schienale movimento a cricchetto optional.

Optional back with ratchet movement.

Dossier avec mouvement à cliquet en option.

• LISTINO PREZZI / PRICE LIST / LISTE DES PRIX pag. 329

UNA COLLEZIONE FACILE PRATICA RESISTENTE

Apertura a rotazione dello schienale.

Un solo movimento per passare dal divano al letto: lo schienale ruota insieme alla seduta senza rimuovere i cuscini, creando così un comodo e pratico letto... Meccanismi ad alta resistenza e servoassistiti.

1. Contenitore per guanciali del letto.
2. Sistema di aggancio materasso rete.
3. Robusto telaio in metallo e rete elettrosaldata indeformabile.
4. Un materasso comodo e indeformabile H17 cm.
5. Pratica e robusta zip per sfoderare.

Tutto interamente sfoderabile e lavabile in modo semplice e veloce. Tutto interamente smontabile grazie al sistema a baionetta semplice e robusto. Particolarmente pratico per movimentazioni, traslochi e eventuali sostituzione di braccioli.

An easy, practical, resistant collection

Opening through rotation of the back Just one move to switch from the sofa to the bed: the backrest rotates together with the seat without removing the cushions, thus creating a convenient and practical bed... High strength servo-mechanisms.

1. Container for the bed pillows.
2. Mattress support coupling system.
3. Sturdy metal frame and undeformable electro-welded support.
4. The mattress comfortable, and undeformable
5. Practical and sturdy zipper to pull off.

All fully removable and washable easily and fast. All completely detachable thanks to the simple and robust bayonet system. Especially convenient for handling, moving and replacing arms.

Une collection facile pratique et résistante

Ouverture par rotation du dossier. Transformation en lit en un seul geste: le dossier tourne avec l'assise sans avoir à retirer les coussins créant ainsi un lit pratique et confortable... Des mécanismes à haute résistance et servo-assistés.

1. Coffre de rangement pour oreillers.
2. Système de fixation du matelas au sommier.
3. Robuste cadre en métal et sommier électrosoudé indéformable.
4. Matelas confortable et indéformable.
5. Fermeture à glissière pratique et robuste pour le déhousseage.

Tout est entièrement déhousable et lavable, facilement et rapidement. Tout est entièrement démontable grâce au système à baïonnette simple et robuste. Particulièrement pratique en cas de déplacements, déménagement et remplacement d'accoudoirs.

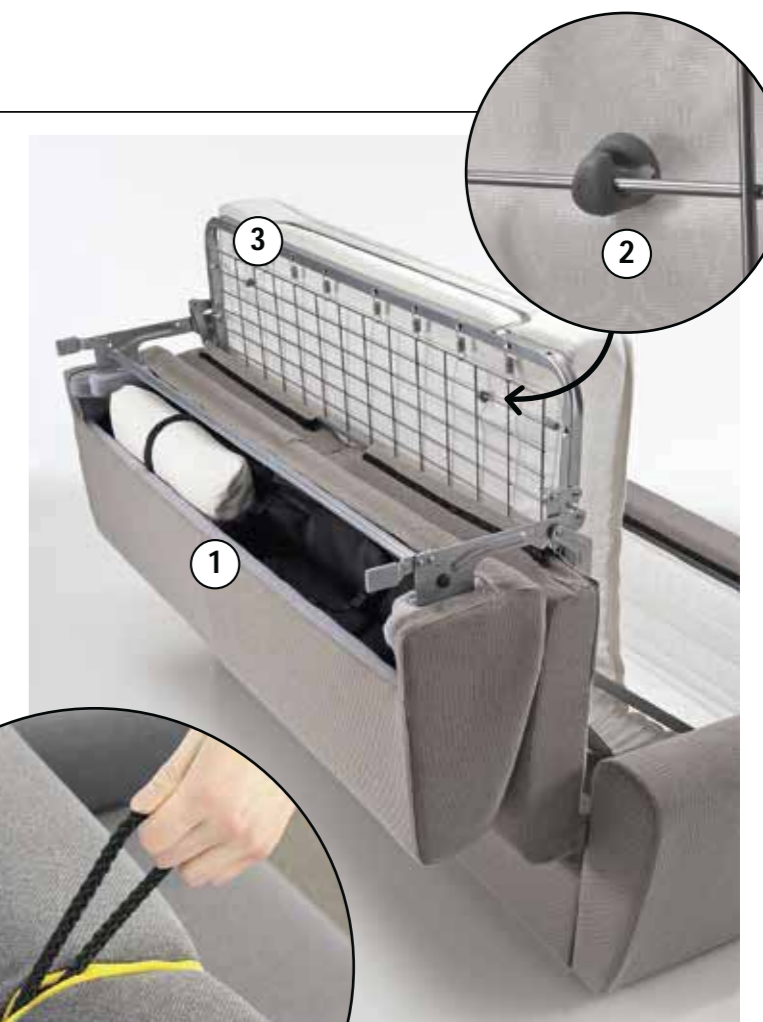

Sistema di apertura facilitata.
Easy opening system
Système d'ouverture facile



cm 17
OPTIONAL



• LISTINO PREZZI / PRICE LIST / LISTE DES PRIX pag. 329

STANDARD

Materasso espanso D.25 / D.25 foam mattress / Matelas en mousse D.25

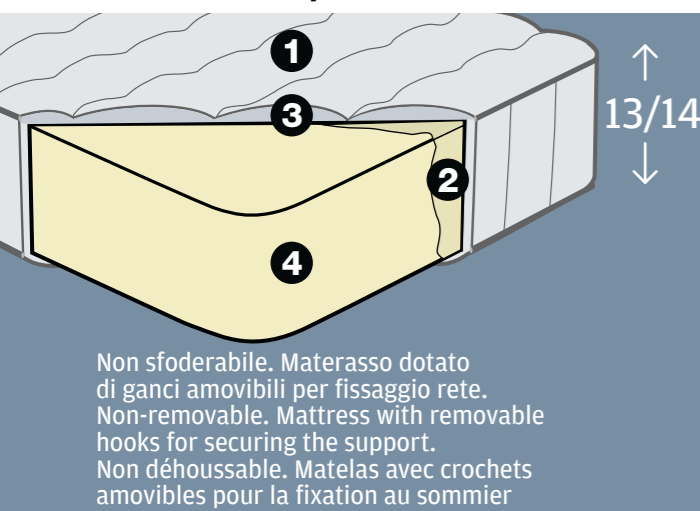

Non sfoderabile. Materasso dotato di ganci amovibili per fissaggio rete. Non-removable. Mattress with removable hooks for securing the support. Non déhoussable. Matelas avec crochets amovibles pour la fixation au sommier

Caratteristica / Characteristic / Caractéristique			Valore / Value / Valeur	
Dimensioni finite Finished size Dimensions finies	altezza / height / hauteur lunghezza / length / longueur larghezza / width / largeur	cm cm cm	13/14 da 197 da 70 a 160	
1 Tessuto rivestimento Fabric Tissu de revêtement	trapuntato su due lati quilted on both sides matelassé sur les deux faces	poliestere stretch stretch polyester polyester extensible		
densità / density / densité		densità / density / densité		
2 Termolegato 100% poliestere Thermobonded 100% polyester Collé à chaud 100% polyester	gr. m ² 350	4 Espanso di polietera Polyether foam Mousse de polyester	gr. m ³ 30	
3 TNT bianco 100% poliestere TNT white 100% polyester TNT blanc 100% polyester	gr. m ² 15			

Rete

Meccanica con tubolare d'acciaio a sezione quadra verniciata con polveri epossidiche e dotata di meccanismo testato dal nostro ufficio tecnico per oltre 2.000 cicli di apertura.

Il piano dormita supporta il peso di due persone adulte di peso medio senza deformarsi.

Telaio

Realizzato con masselli di abete in vari spessori, parti di tamponamento in fibra di legno e/o compensato, fianchi in agglomerato di legno da 18 mm.

Fibra grezza e/o agglomerato di legno a bassa emissione di formaldeide, il tutto rivestito con vellutino 100% poliammide termoaccoppiato ad espanso di poliester e/o ovatta di poliester 100% da 200gr.

Imbottitura

Seduta in espanso indeformabile di polietera sagomato in D28 ny portanza 3,6.

Rivestimento cuscino seduta sagomato ed incollato, composto da resinato di poliester 100% da 200gr.

Schiena in espanso indeformabile di polietera D18 portanza 1,6.

Braccioli tampona in espanso indeformabile sagomato in polietera D40 portanza 8,0.

Support

Mechanic system consisting of a square section steel tube coated with epoxy powder and equipped with a mechanism tested by our technical department for more than 2,000 cycles of opening.

The structure supports the weight of two adult people of average weight, without deforming.

Frame

Made from solid spruce in various thicknesses, the filling parts are in wood fibre and/or plywood, the sides are made from 18 mm chipboard. Crude fibre and/or low formaldehyde emission chipboard, all covered with 100% polyamide velvet, thermocoupled with polyester foam and/or 100% 200g. polyester wadding.

Padding

Seats made with inalterable shaped polyether foam D28 ny, carrying capacity 3.6.

Shaped and glued seat cushion padding, consisting of 200g. 100% polyester resin. Backrest made with inalterable polyether foam D18, carrying capacity 1.6.

Armrests made with inalterable shaped polyether foam D40, carrying capacity 8.0.

Mécanisme lit

Système mécanique avec tube d'acier à section carrée verni avec poudre époxy et équipé d'un mécanisme testé par notre service technique sur plus de 2 000 cycles d'ouverture. Le plan de couchage peut supporter le poids de deux adultes de poids moyen sans se déformer.

Cadre

Fabriqué en bois massif de sapin de différentes épaisseurs, pièces de remplissage en fibre de bois et/ou contreplaqué, panneaux latéraux en bois aggloméré de 18 mm. Fibres brutes et/ou bois aggloméré à faible émission de formaldéhydes, le tout revêtu de velours 100% polyamide relié à chaud à de la mousse de polyester et/ou ouate 100% polyester de 200 g.

Rembourrage

Assise en mousse indéformable de polyester façonnée en D28 avec force portante de 3,6.

Revêtement du coussin de l'assise formé et collé, constitué de résines 100% polyester de 200g.

Dossier en mousse indéformable de polyester D18 avec force portante de 1,6.

Accoudoir tampon en mousse indéformable moulé en polyester D40 avec force portante de 8,0.

Informazioni ambientale e sulla sicurezza

La deperibilità del prodotto, secondo la sua composizione, è praticamente nulla.

Le resine espanso non sono contenute nella lista della normativa di classificazione dei rifiuti per materiali soggetti a particolare sorveglianza.

Le resine espanso sono esenti da freon e solventi clorurati. Le resine espanso non contengono sostanze che danneggiano l'ozonofera e non vengono fabbricate con prodotti menzionati nel protocollo di Montreal e Regolamento (Ce) n. 3093/94.

Information on environment and safety

The perishable nature of the product, according to its composition, is practically nil.

Resin foams are not included in the list of rules for the classification of waste materials subject to special surveillance.

Resin foams are free from freon and chlorinated solvents. Resin foams do not contain substances that damage the ozone layer and are not manufactured with products mentioned in the Montreal Protocol and (CE) Regulation no. 3093/94.

Informations sur l'environnement et la sécurité

La nature périssable du produit, en fonction de sa composition, est pratiquement nulle.

Les résines expansées ne figurent pas dans la liste établie par la norme de classification des déchets de matériaux soumis à une surveillance particulière.

Les résines expansées ne contiennent pas de fréon ni de solvants chlorés. Les résines expansées ne contiennent pas de substances nuisibles à la couche d'ozone et ne sont pas fabriquées avec des produits figurant dans le Protocole de Montréal et le Règlement (CE) n° 3093/94.

OPTIONAL

A Materasso comfort D.30 / D.30 foam mattress / Matelas Comfort D.30

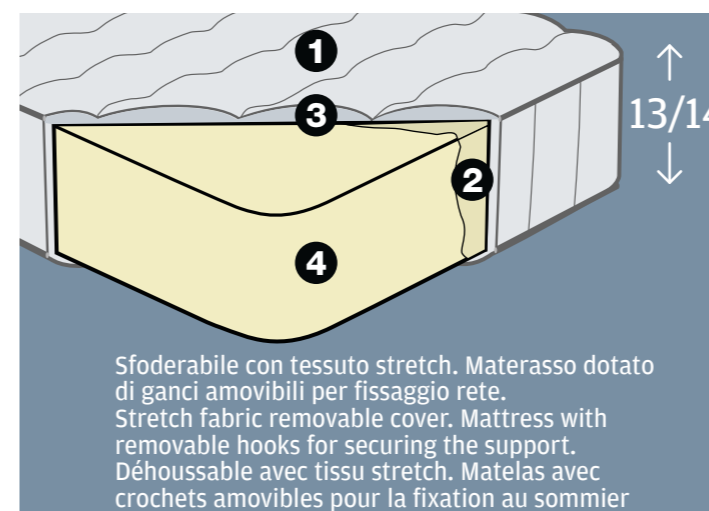

Sfoderabile con tessuto stretch. Materasso dotato di ganci amovibili per fissaggio rete. Stretch fabric removable cover. Mattress with removable hooks for securing the support. Déhoussable avec tissu stretch. Matelas avec crochets amovibles pour la fixation au sommier

Caratteristica / Characteristic / Caractéristique			Valore / Value / Valeur	
Dimensioni finite Finished size Dimensions finies	altezza / height / hauteur lunghezza / length / longueur larghezza / width / largeur	cm cm cm	13/14 da 197 da 70 a 160	
1 Tessuto rivestimento Fabric Tissu de revêtement	trapuntato su due lati quilted on both sides matelassé sur les deux faces	poliestere stretch stretch polyester polyester extensible		
densità / density / densité		densità / density / densité		
2 Termolegato 100% poliestere Thermobonded 100% polyester Collé à chaud 100% polyester	gr. m ² 350	4 Espanso di polietera Polyether foam Mousse de polyester	gr. m ³ 30	
3 TNT bianco 100% poliestere TNT white 100% polyester TNT blanc 100% polyester	gr. m ² 15			

B Materasso Memory Foam / Memory Foam Mattress / Matelas Memory Foam

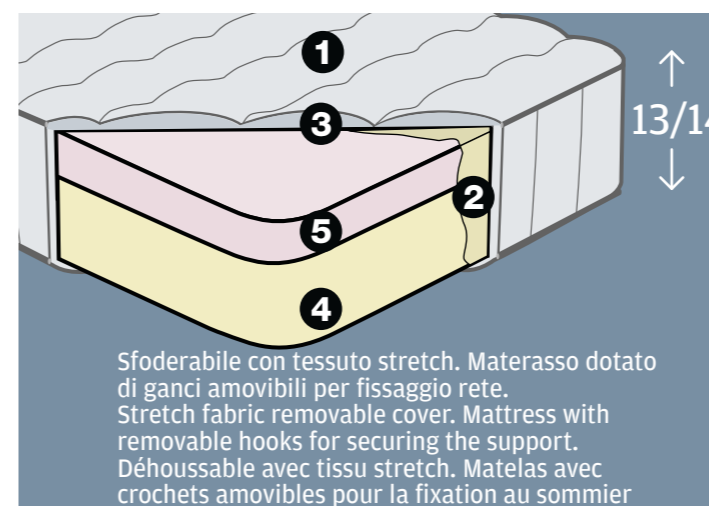

Sfoderabile con tessuto stretch. Materasso dotato di ganci amovibili per fissaggio rete. Stretch fabric removable cover. Mattress with removable hooks for securing the support. Déhoussable avec tissu stretch. Matelas avec crochets amovibles pour la fixation au sommier

Caratteristica / Characteristic / Caractéristique			Valore / Value / Valeur	
Dimensioni finite Finished size Dimensions finies	altezza / height / hauteur lunghezza / length / longueur larghezza / width / largeur	cm cm cm	13/14 da 197 da 70 a 160	
1 Tessuto rivestimento Fabric Tissu de revêtement	trapuntato su due lati quilted on both sides matelassé sur les deux faces	poliestere stretch stretch polyester polyester extensible		
densità / density / densité		densità / density / densité		
2 Termolegato 100% poliestere Thermobonded 100% polyester Collé à chaud 100% polyester	gr. m ² 350	4 Espanso di polietera Polyether foam Mousse de polyester	gr. m ³ 28	
3 TNT bianco 100% poliestere TNT white 100% polyester TNT blanc 100% polyester	gr. m ² 15	5 Memory Foam Memory Foam Memory Foam	gr. m ³ 45	

C Materasso High Comfort H 17 / 17 H High Comfort Mattress / Matelas High Comfort H 17

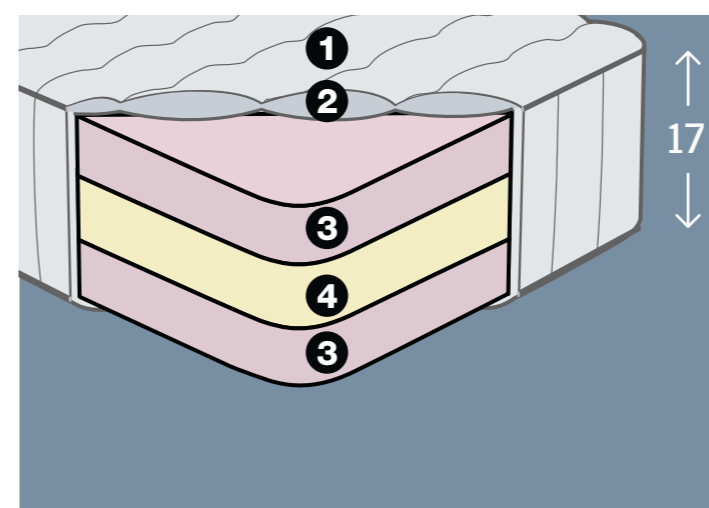

Non sfoderabile. Materasso dotato di ganci amovibili per fissaggio rete. Non-removable. Mattress with removable hooks for securing the support. Non déhoussable. Matelas avec crochets amovibles pour la fixation au sommier

Caratteristica / Characteristic / Caractéristique			Valore / Value / Valeur	
Dimensioni finite Finished size Dimensions finies	altezza / height / hauteur lunghezza / length / longueur larghezza / width / largeur	cm cm cm	17 da 197 da 70 a 160	
1 Tessuto rivestimento Fabric Tissu de revêtement	Stretch sagomato e cucito Shaped and sewn stretch Stretch moulé et cousu	Poliestere 100% antiacaro 100% anti-mite polyester Polyester 100% anti-acarien	Da 250 gr 250 gr de 250 g	
densità / density / densité		densità / density / densité		
2 Falda in poliester 100% 100% polyester layer Couche 100% polyester			gr. m ² 250	
3 Espanso indeformabile Non-deformable foam Mousse indéformable			gr. m ² 26 NY	
resistenza alla compressione / compressive strength / résistance à la compression		40% KPA -> 3.8		
4 Espanso indeformabile airsoft (olmo) Airsoft non-deformable foam (elm) Mousse indéformable airsoft (orme)			gr. m ³ 25	
resistenza alla compressione / compressive strength / résistance à la compression		40% KPA -> 1.200		

SPACE style

Il meno è più.

Less is more.

Le moins est un plus. - M. V. Der Roohe

ORDINE CON IL BRACCIOLO CONTENITORE

Ampia la seduta, confortevole lo schienale, comodi e ampi i braccioli dotati di cuscino. Space è un divano perfetto per accogliere. Perfetto per tenere tutto in ordine perché sotto i braccioli è dotato di un pratico portariviste. Le tue letture preferite saranno a portata di mano.

ORDER WITH CONTAINER ARMREST

Wide seats, a comfortable backrest, wide and cosy armrests, equipped with a cushion. Space is a perfect welcoming sofa. Perfect for keeping everything in order, because under the armrests there is a practical magazine rack. Your favourite books will be on hand.

COMMANDE AVEC ACCOUDOIR ÉQUIPÉ D'UN RANGEMENT

Une assise ample, un dossier confortable, des accoudoirs commodes et confortables dotés d'un coussin. Space est un canapé idéal pour recevoir. Il est parfait pour garder tout en ordre car il dispose, sous les accoudoirs, d'un porte-magazines très pratique. Vos lectures préférées seront à portée de main.



Sotto i braccioli,
un pratico portariviste

Under the armrests, a
practical magazine rack.

Sous les accoudoirs, un
pratique porte-magazines

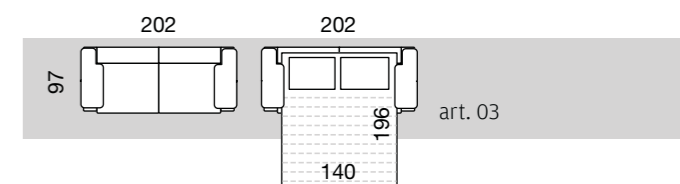

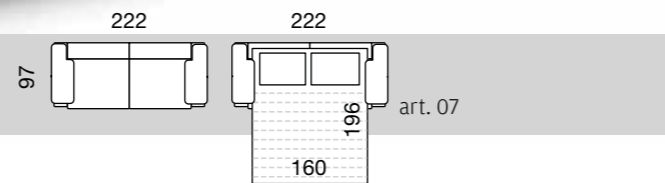

Struttura

Telaio in legno con parti in abete essiccato di vari spessori, agglomerato di legno da 18 mm e multistrato di pino e/o pioppo da 18 mm, in classe E1, pertanto a bassa emissione di formaldeide. Il tutto rivestito da maglia di poliestere termoaccoppiata ad espanso e/o ovatta di poliestere.

Molleggio (divani fissi)

Realizzato mediante nastri elastici da mm 80 tesi meccanicamente, composti da fili di gomma ricoperti da nylon avvolto a spirale.

Imbottitura e piedi

Cuscino seduta in poliuretano espanso in D25 indeformabile portante, rivestito in resinato di poliestere da g 200. Cuscini schienale in D16S rosa indeformabile. Cuscini bracciolo in TNT d 60 con fiocco di poliestere siliconato vergine e/o D40PK indeformabile, rivestito in falda termolegata da g 300. Tamponi bracciolo in D18 indeformabile.

Piede in ABS h 80 mm con vite.

Meccanismo letto

Tubi in acciaio diametro mm 30. Meccanismi particolari stampati in acciaio. Rete elettrosaldato, filo in acciaio saldato elettricamente. Il tutto verniciato con resina epossipoliestere. Particolari in plastica in polietilene. Portata di sicurezza kg 180. Materasso a molle elicoidali a compressione, acciaio temperato C70, con imbottitura in poliuretano espanso D21P indeformabile ambo i lati, ovatta agugliata, rivestito in tela trapuntata in cotone 100%. Lunghezza cm 200 +/- 1, spessore cm 14 +/- 0,5.

Materasso

A molle biconiche in acciaio, con imbottitura in poliuretano espanso D21

indeformabile, rivestito in cotone eco tex trapuntato su ambedue i lati. Spessore 12 cm +/- 2 cm. OPZIONALE 1: materasso a molle biconiche in acciaio spes. D.2.2 trapuntato e rivestito in poliestere e cotone su ambedue i lati. OPZIONALE 2: materasso in poliuretano espanso indeformabile D25 spessore 12 cm +/- 2 cm, rivestito in poliestere e cotone su ambedue i lati.

Structure

Wood frame with parts in dried fir, wood chipboard of mm 18. Multilayer in pine and/or poplar of mm 18. All covered in expanded thermal coupled polyester mesh and/or polyester padding. All made from wood chips in class E1, therefore with low emission of formaldehyde.

Springs (fixed elements)

Made of elastic bands of mm 80, mechanically tensioned, composed of rubber wires covered in spiral-wrapped nylon.

Upholstery and feet

Seat cushion in expanded polyurethane D25 non deformable load-bearing, covered in polyester resin of g 200. Back cushion in D16S pink non-deformable. Armrest cushion in TNT g 60 with virgin silicon polyester stuffing and/or D40PK non-deformable, covered with thermal-bound felt of g 300. Armrest fillers in D18 non-deformable. Foot in ABS h 80 w/screw.

Bed mechanism

Steel tuber diameter mm 30. Mechanism parts pressed in steel. Electro-welded

base; steel wire electrically welded. All painted with epoxy-polyester resin. Safe load-bearing weight kg 180. Mattress with helicoidal compression springs, tempered steel C70, with padding in expanded polyurethane D21P non-deformable both sides, stitched padding, covered with quilted 100% cotton. Length cm 200 +/- 1, thickness cm 14 +/- 0,5. Mattress in expanded polyurethane D21P non-deformable thickness cm 12, covered with quilted 100% cotton. Length cm 200 +/- 1, thickness cm 14 +/- 0,5.

Mattress

With biconical steel springs, padding in polyurethane foam with D21, indeformable, covered in ecotex, quilted on both sides. 12 cm +/- 2 cm thickness. OPTIONAL 1: mattress with biconical steel springs, D.2.2 thickness, quilted and covered in polyester and cotton on both sides. OPTIONAL 2: mattress in D25 indeformable polyurethane foam, 12 cm +/- 2 cm thickness, covered in polyester and cotton on both sides.

Structure

Cadre en bois avec parties en sapin séché de plusieurs épaisseurs, bois aggloméré de 18 mm et multiplis de pin et/ou de peuplier de 18 mm, de classe E1, donc à basse émission de formaldéhyde. Le tout revêtu de jersey de polyester associé thermiquement à l'expansé et/ou à la ouate de polyester.

Suspension (canapés fixes)

Réalisée à l'aide de sangles élastiques de 80 mm tendues mécaniquement, composées de fils de caoutchouc recouverts de nylon enroulé en spirale.

Rembouillage et pieds

Coussin de l'assise en polyuréthane expansé en D25 indéformable portant, revêtu de résine de polyester de 200 g. Coussins du dossier en D16S rose indéformable. Coussins de l'accoudoir en TNT d 60 avec flocon de polyester à la silicone vierge et/ou D40PK indéformable, revêtu de voile associé thermiquement de 300 g. Fileurs accoudoir en D18 indéformable. Pied en ABS h 80 mm avec vis.

Mécanisme lit

Tubes en acier diamètre 30 mm. Mécanismes particuliers estampés en acier. Sommier électrosoudé, fil en acier soudé électriquement. Le tout peint avec une résine époxy polyester. Détails en plastique polyéthylène. Portée de sécurité 180 kg. Matelas à ressorts hélicoïdaux à compression, acier trempé C70, cm rembourrage en polyuréthane expansé D21P indéformable des deux côtés, ouate aiguilletée, revêtu en toile matelassée en coton 100%. Longueur cm 200 +/- 1, épaisseur cm 14 +/- 0,5.

Matelas

A ressorts bi-coniques en acier, avec rembourrage en polyuréthane expansé D21 indéformable, revêtu de coton eco tex matelassé des deux côtés. Épaisseur 12 cm +/- 2 cm. OPTION 1 : matelas à ressorts bi-coniques en acier épais. D.2.2 matelassé et revêtu de polyester et coton des deux côtés. OPTION 2 : matelas en polyuréthane expansé indéformable D25 épaisseur 12 cm +/- 2 cm, revêtu de polyester et coton des deux côtés.

Disponibile anche
in versione fissa

Also available in
the fixed version

Également disponible
en version fixe

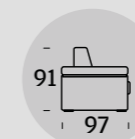

Art. 01
Poltrona/Letto
Chair bed
Fauteuil convertible

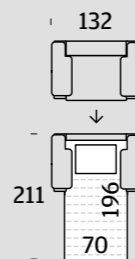

Art. 02
Divano/letto 2 posti
2-seater sofa bed
Canapé convertible
2 places

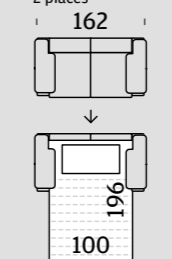

Art. 20
Divano/letto 2 posti grande
2-seater large sofa bed
Canapé convertible
2 grandes pl.

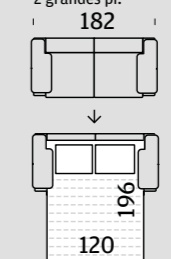

Art. 03
Divano/letto 3 posti
3-seater sofa bed
Canapé convertible
3 places

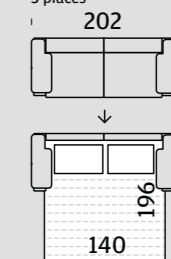

Art. 07
Divano/letto 3 posti maxi
Maxi 3-seater sofa bed
Canapé convertible
3 places maxi

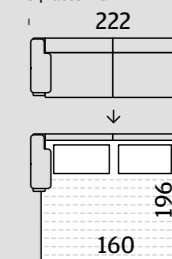

Art. 1D-1S
Laterale/letto 1 posto
RH-LH 1-seater side el.
Canapé bâtarde 1 place D-G

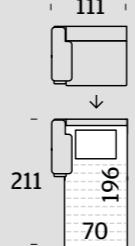

Art. 2D-2S
Laterale/letto 2 posti
RH-LH 2-seater side el.
Canapé bâtarde 2 places D-G

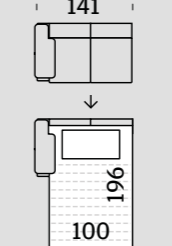

Art. GD-GS
Laterale/letto 2 posti grande
RH-LH 2-seater large side el.
Canapé bâtarde 2 grandes pl. D-G

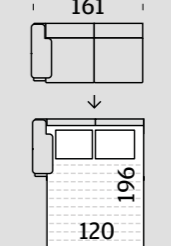

Art. 3D-3S
Laterale/letto 3 posti
RH-LH 3-seater side el.
Canapé bâtarde 3 places D-G

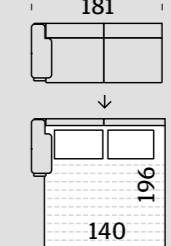

Art. 7D-7S
Laterale/letto 3 posti maxi
RH-LH maxi 3-seater side el.
Canapé bâtarde 3 maxi places D-G

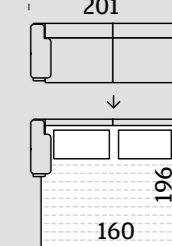

Art. CD-CS
Chaise longue
RH-LH chaise longue
Mériidienne D-G

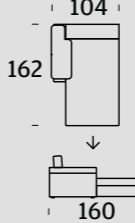

Art. XD-XS
Chaise longue c/contentore
RH-LH chaise longue with storage
Mériidienne D-G rangement

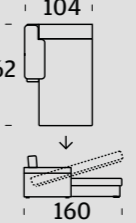

Esempi compositivi - Compositional examples - Exemples de composition

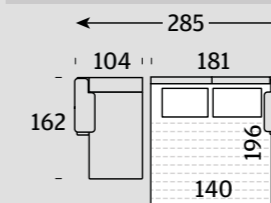

• LISTINO PREZZI / PRICE LIST / LISTE DES PRIX pag. 336



FLAIR style

L'architetto è un muratore che sa il latino.

An architect is a mason who knows Latin.

L'architecte est un maçon qui parle latin. - Adolf Loos

CLASSICO SENZA TEMPO

La linea curva dei braccioli dona a Flair un accento classico e raffinato. Perfetto per arredare anche ambienti moderni, il divano letto è molto pratico grazie al meccanismo di rotazione dello schienale.

A TIMELESS CLASSIC

The curved line of the armrests gives Flair a classic and refined accent. Also perfect for decorating modern environments, this sofa bed is very practical, thanks to the mechanism of rotation of the backrest.

LE CLASSIQUE INTEMPOREL

La ligne courbe des accoudoirs donne à Flair un accent classique et raffiné. Parfait également pour meubler les ambiances modernes, ce canapé-lit est très pratique grâce à son mécanisme de rotation du dossier.

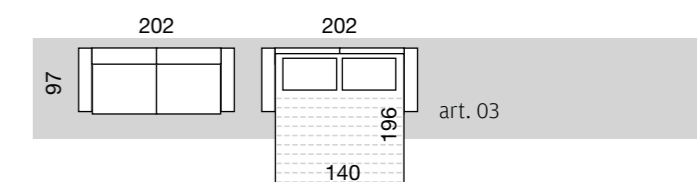

A WARM WELCOME



Struttura

Telaio in legno con parti in abete essiccato di vari spessori, agglomerato di legno da 18 mm e multistrato di pino e/o pioppo da 18 mm, in classe E1, pertanto a bassa emissione di formaldeide. Il tutto rivestito da maglia di poliestere termoaccoppiata ad espanso e/o ovatta di poliestere.

Molleggio (divani fissi)

Realizzato mediante nastri elastici da mm 80 tesi meccanicamente, composti da fili di gomma ricoperti da nylon avvolto a spirale.

Imbottitura e piedi

Cuscino seduta in poliuretano espanso in D25 indeformabile portante, rivestito in resinato di poliestere da g 200. Cuscini schienale in D16S rosa indeformabile. Cuscini bracciolo in TNT d 60 con fiocco di poliestere silconato vergine e/o D40PK indeformabile, rivestito in falda termolegata da g 300. Tamponi

bracciolo in D18 indeformabile. Piede in ABS h 80 mm con vite.

Meccanismo letto

Tubi in acciaio diametro mm 30. Meccanismi particolari stampati in acciaio. Rete elettrosaldata, filo in acciaio saldato elettricamente. Il tutto verniciato con resina epossipolistere. Particolari in plastica in polietilene.

Portata di sicurezza kg 180. Materasso a molle elicoidali a compressione, acciaio temperato C70, con imbottitura in poliuretano espanso D21P indeformabile ambo i lati, ovatta agugliata, rivestito in tela trapuntata in cotone 100%. Lunghezza cm 200 +/- 1, spessore cm 14 +/- 0,5.

Materasso

A molle biconiche in acciaio, con imbottitura in poliuretano espanso D21 indeformabile, rivestito in cotone eco tex trapuntato su

ambidue i lati. Spessore 12 cm +/- 2 cm. OPZIONALE 1: materasso a molle biconiche in acciaio spes. D.2.2 trapuntato e rivestito in poliestere e cotone su ambedue i lati. OPZIONALE 2: materasso in poliuretano espanso indeformabile D25 spessore 12 cm +/- 2 cm, rivestito in poliestere e cotone su ambedue i lati.

Structure

Wood frame with parts in dried fir, wood chipboard of mm 18. Multilayer in pine and/or poplar of mm 18. All covered in expanded thermal coupled polyester mesh and/or polyester padding. All made from wood chips in class E1, therefore with low emission of formaldehyde.

Springs (fixed elements)

Made of elastic bands of mm 80, mechanically tensioned, composed of rubber wires covered in spiral-wrapped nylon.

Upholstery and feet

Seat cushion in expanded polyurethane D25 non deformable load-bearing, covered in polyester resin of g 200. Back cushion in D16S pink non-deformable. Armrest cushion in TNT g 60 with virgin silicon polyester stuffing and/or D40PK indeformable, covered with thermal-bound felt of g 300. Armrest fillers in D18 non-deformable. Foot in ABS h 80 w/screw.

Bed mechanism

Steel tuber diameter mm 30. Mechanism parts pressed in steel. Electro-welded base; steel wire electrically welded. All painted with epoxy-polyester resin.

Safe load-bearing weight kg 180. Mattress with helicoidal compression springs, tempered steel C70, with padding in expanded polyurethane D21P non-deformable both sides, stitched padding, covered with quilted 100% cotton. Length cm 200 +/- 1, thickness cm 14 +/- 0,5. Mattress in expanded polyurethane D21P non-deformable thickness cm 12, covered with quilted 100% cotton. Length cm 200 +/- 1, thickness cm 14 +/- 0,5.

Mattress

With biconical steel springs, padding in polyurethane foam with D21, indeformable, covered in ecotex, quilted on both sides. 12 cm +/- 2 cm thickness. OPTIONAL 1: mattress with biconical steel springs, D.2.2 thickness, quilted and covered in polyester and cotton on both sides. OPTIONAL 2: mattress in D25 indeformable polyurethane foam, 12 cm +/- 2 cm thickness, covered in polyester and cotton on both sides.

Structure

Cadre en bois avec parties en sapin séché de plusieurs épaisseurs, bois aggloméré de 18 mm et multiplis de pin et/ou de peuplier de 18 mm, de classe E1, donc à basse émission de formaldéhyde. Le tout revêtu de jersey de polyester associé thermiquement à l'expansé et/ou à la ouate de polyester.

Suspension (canapés fixes)

Réalisée à l'aide de sangles élastiques de 80 mm tendues mécaniquement, composées de fils de caoutchouc recouverts de nylon enroulé en spirale.

Rembouillage et pieds

Coussin de l'assise en polyuréthane expansé en D25 indéformable portant, revêtu de résine de polyester de 200 g. Coussins du dossier en D16S rose indéformable. Coussins de l'accoudoir en TNT d 60 avec flocon de polyester à la silicone vierge et/ou D40PK indéformable, revêtu de voile associé thermiquement de 300 g. Fileurs accoudoir en D18 indéformable. Pied en ABS h 80 mm avec vis.

Mécanisme lit

Tubes en acier diamètre 30 mm. Mécanismes particuliers estampés en acier. Sommier électrosoudé, fil en acier soudé électriquement. Le tout peint avec une résine époxy polyester. Détails en plastique polyéthylène. Portée de sécurité 180 kg. Matelas à ressorts hélicoïdaux à compression, acier trempé C70, cm rembourrage en polyuréthane expansé D21P indéformable des deux côtés, ouate aiguilletée, revêtu en toile matelassée en coton 100%. Longueur cm 200 +/- 1, épaisseur cm 14 +/- 0,5.

Matelas

A ressorts bi-coniques en acier, avec rembourrage en polyuréthane expansé D21 indeformabile, revêtu de coton éco tex matelassé des deux côtés. Épaisseur 12 cm +/- 2 cm. OPTION 1 : matelas à ressorts bi-coniques en acier épais. D.2.2 matelassé et revêtu de polyester et coton des deux côtés. OPTION 2 : matelas en polyuréthane expansé indeformabile D25 épaisseur 12 cm +/- 2 cm, revêtu de polyester et

Disponibile anche
in versione fissa

Also available in
the fixed version

Également disponible
en version fixe

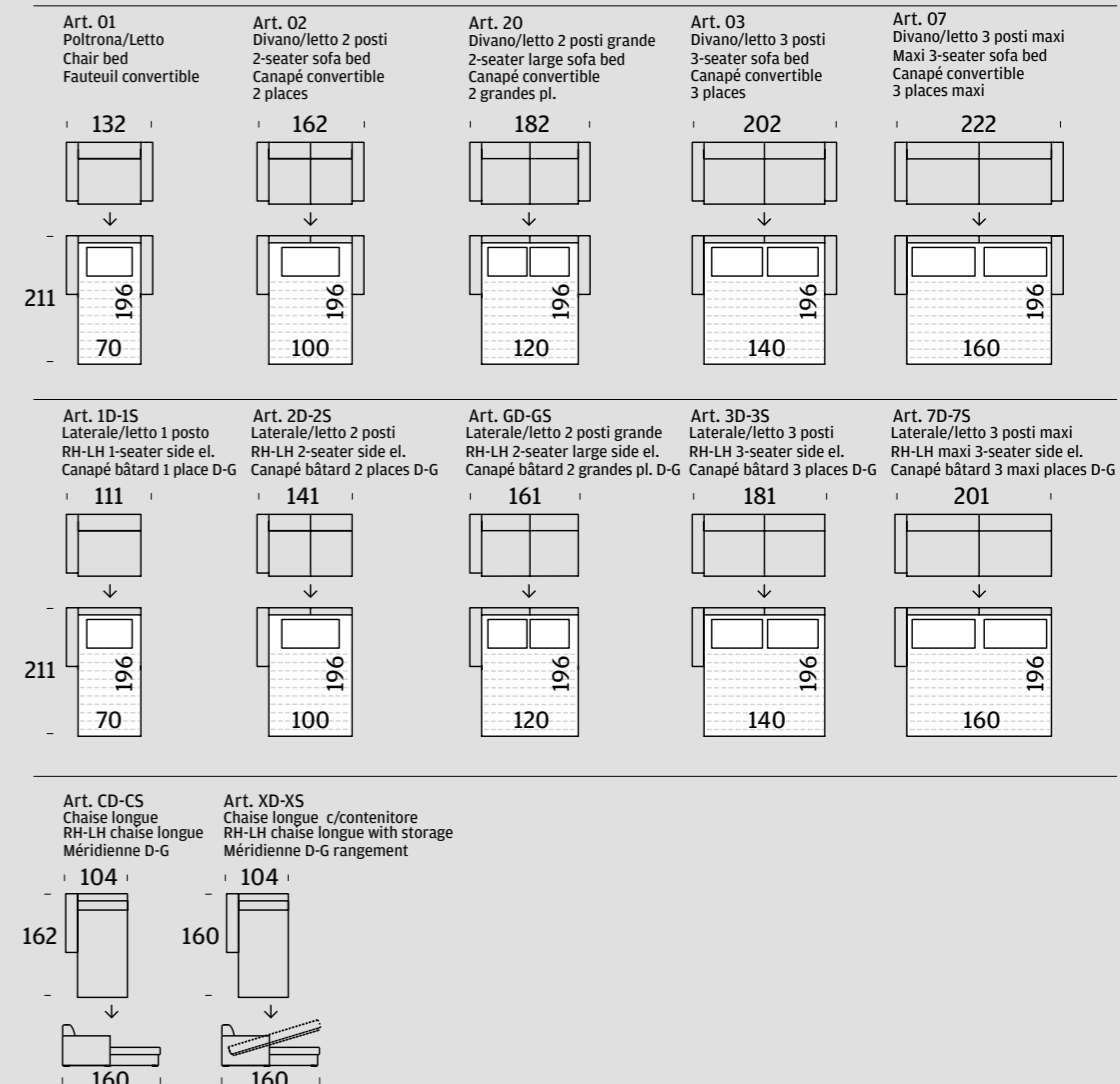
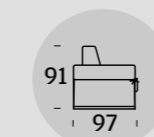

Esempi compositivi - Compositional examples - Exemples de composition

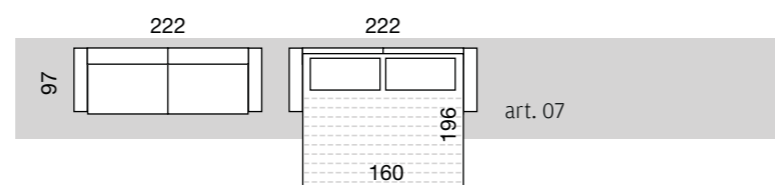
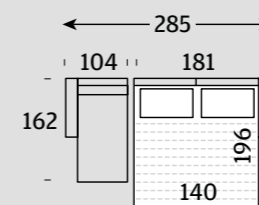

ARIK style

L'architettura è una scultura abitata.

Architecture is an inhabited sculpture.

L'architecture est sculpture habitée. - Constantin Brâncuși

MORBIDA MODERNITA'

Caratterizzato dai braccioli leggermente sagomati, Arik è un divano letto moderno, confortevole, elegante. Perfetto per chi non vuole rinunciare allo stile ma vuole garantirsi spazio da dedicare all'ospitalità.

MODERN SOFTNESS

Characterized by slightly contoured armrests, Arik is a modern sofa bed, comfortable, stylish. Perfect for those who like style, but also want a space to devote to hospitality.

DOUCE MODERNITÉ

Caractérisé par des accoudoirs légèrement découpés, Arik est un canapé-lit moderne, confortable et élégant. Parfait pour qui ne souhaite pas renoncer au style tout en garantissant un espace à consacrer à l'hospitalité.

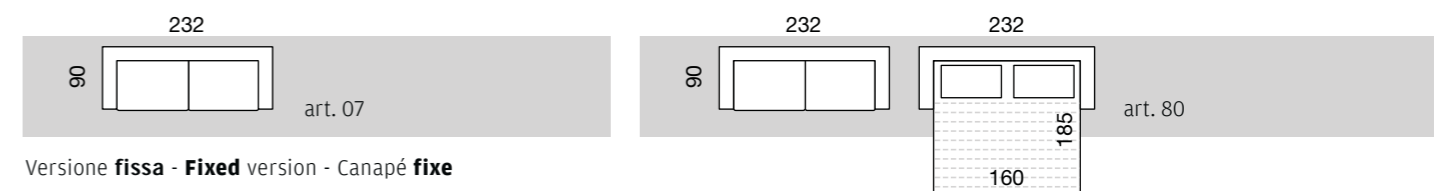



IL COLORE DELLE PARETI

Ricorda che il colore delle pareti non è soltanto un dettaglio accessorio, anzi condiziona l'atmosfera complessiva di un ambiente in modo insospettabile. Il tono delle pareti lascia un'impronta profonda sull'aspetto dell'intera stanza, delineandone il mood e interagendo con l'arredamento per contrasto o affinità.

WALL COLOURS

Remember that the colour of the walls is not only an accessory detail; on the contrary, it affects the overall atmosphere of an environment unexpectedly. The colour of the walls leaves a deep impression on the appearance of the entire room, outlining its mood and interacting with the decor by contrast or affinity.

LA COULEURS DES MURS

Rappelez-vous que la couleur des murs n'est pas seulement un détail, mais affecte bel et bien l'ambiance générale d'une pièce de manière inattendue. La couleur des murs laisse une profonde empreinte sur l'apparence de la pièce, en délimitant l'atmosphère et en interagissant avec la décoration pour un meilleur contraste ou affinité.



Versione **fissa** - Fixed version - Canapé **fixe**

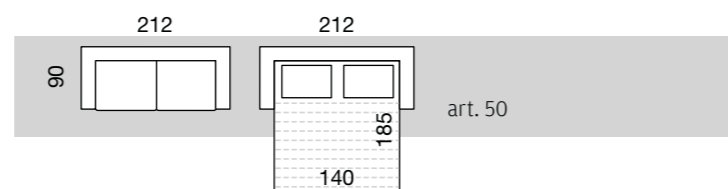

Struttura

Telaio in legno con parti in abete essiccato di vari spessori, agglomerato di legno da 18 mm e multistrato di pino e/o pioppo da 18 mm, in classe E1, pertanto a bassa emissione di formaldeide. Il tutto rivestito da maglia di poliestere termoaccoppiata ad espanso e/o ovatta di poliestere.

Molleggio (divani fissi)

Realizzato mediante nastri elastici da mm 80 tesi meccanicamente, composti da fili di gomma ricoperti da nylon avvolto a spirale.

Imbottitura e piedi

Cuscino seduta in poliuretano espanso in D25 indeformabile portante, rivestito in resinato di poliestere da g 200. Cuscini schienale in D16S rosa indeformabile. Cuscini bracciolo in TNT d 60 con fiocco di poliestere siliconato vergine e/o D40PK indeformabile, rivestito in falda termolegata da g 300. Tamponi bracciolo in D18 indeformabile. Piede in ABS h 80 mm con vite.

Meccanismo letto

Tubi in acciaio diametro mm 30. Meccanismi particolari stampati in acciaio. Rete elettrosaldata, filo in acciaio saldato elettricamente. Il tutto verniciato con resina epossipoliestere. Particolari in plastica in polietilene. Portata di sicurezza kg 180. Materasso a molle elicoidali a compressione, acciaio temperato C70, con imbottitura in poliuretano espanso D21P indeformabile ambo i lati, ovatta agugliata, rivestito in tela trapuntata in cotone 100%. Lunghezza cm 200 +/- 1, spessore cm 14 +/- 0,5.

Materasso

Materasso in poliuretano espanso indeformabile D25 spessore 12 cm +/- 2 cm, rivestito in poliestere e cotone su ambedue i lati.

Structure

Wood frame with parts in dried fir, wood chipboard of mm 18. Multilayer in pine and/or poplar of mm 18. All covered in expanded thermal coupled polyester mesh and/or polyester padding. All made from wood chips in class E1, therefore with low emission of formaldehyde.

Springs (fixed elements)

Made of elastic bands of mm 80, mechanically tensioned, composed of rubber wires covered in spiral-wrapped nylon.

Upholstery and feet

Seat cushion in expanded polyurethane D25 non deformable load-bearing, covered in polyester resin of g 200. Back cushion in D16S pink non-deformable. Armrest cushion in TNT g 60 with virgin silicon polyester stuffing and/or D40PK non-deformable, covered with thermal-bound felt of g 300. Armrest fillers in D18 non-deformable. Foot in ABS h 80 w/screw.

Bed mechanism

Steel tuber diameter mm 30. Mechanism parts pressed in steel. Electro-welded base; steel wire electrically welded. All painted with epoxy-polyester resin. Safe load-bearing weight kg 180. Mattress with helicoidal compression springs, tempered steel C70, with padding in expanded polyurethane D21P non-deformable both sides, stitched padding, covered with quilted 100% cotton. Length

cm 200 +/- 1, thickness cm 14 +/- 0,5. Mattress in expanded polyurethane D21P non-deformable thickness cm 12, covered with quilted 100% cotton. Length cm 200 +/- 1, thickness cm 14 +/- 0,5.

Mattress

Mattress in D25 indeformable polyurethane foam, 12 cm +/- 2 cm thickness, covered in polyester and cotton on both sides.

Structure

Cadre en bois avec parties en sapin séché de plusieurs épaisseurs, bois aggloméré de 18 mm et multiplis de pin et/ou de peuplier de 18 mm, de classe E1, donc à basse émission de formaldéhyde. Le tout revêtu de jersey de polyester associé thermiquement à l'expansé et/ou à la ouate de polyester.

Suspension (canapés fixes)

Réalisée à l'aide de sangles élastiques de 80 mm tendues mécaniquement, composées de fils de caoutchouc recouverts de nylon enroulé en spirale.

Rembourrage et pieds

Coussin de l'assise en polyuréthane expansé en D25 indeformable portant, revêtu de résine de polyester de 200 g. Coussins du dossier en D16S rose indeformable. Coussins de l'accoudoir en TNT d 60 avec flocon de polyester à la silicone vierge et/ou D40PK indeformable, revêtu de voile associé thermiquement de 300 g. Fileurs accoudoir en D18 indeformable.

Pied en ABS h 80 mm avec vis.

Mécanisme lit

Tubes en acier diamètre 30 mm. Mécanismes particuliers estampés en acier. Sommier électrosoudé, fil en acier soudé électriquement. Le tout peint avec une résine époxy polyester. Détails en plastique polyéthylène. Portée de sécurité 180 kg. Matelas à ressorts hélicoïdaux à compression, acier trempé C70, en rembourrage en polyuréthane expansé D21P indeformable des deux côtés, ouate aiguilletée, revêtu en toile matelassée en coton 100%. Longueur cm 200 +/- 1, épaisseur cm 14 +/- 0,5.

Matelas

Matelas en polyuréthane expansé indeformable D25 épaisseur 12 cm +/- 2 cm, revêtu de polyester et coton des deux côtés.

Disponibile anche in versione fissa

Also available in the fixed version

Également disponible en version fixe

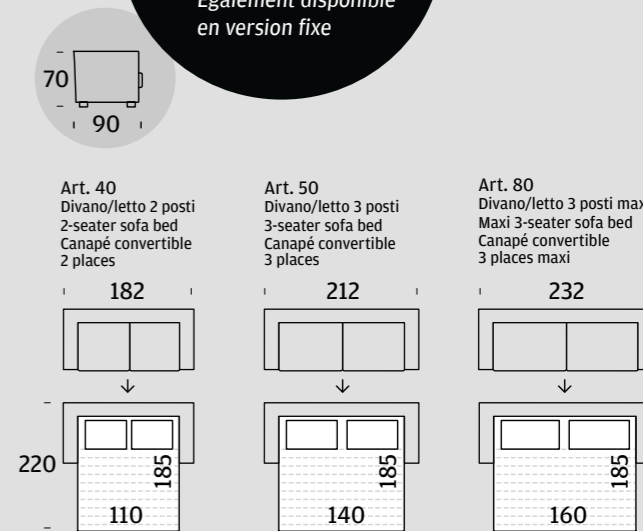

VERSIONE FISSA - FIXED VERSION - CANAPÉ FIXE

Art. 02
Divano/letto 2 posti
2-seater sofa bed
Canapé convertible
2 places

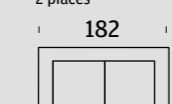

Art. 03
Divano/letto 3 posti
3-seater sofa bed
Canapé convertible
3 places



Art. 07
Divano/letto 3 posti maxi
Maxi 3-seater sofa bed
Canapé convertible
3 places maxi

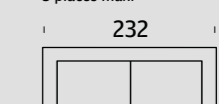

Art. 18
Cuscino rettangolare
Rectangular cushion
Coussin rectangulaire
23x60



Art. 15
Cuscino
Cushion
Coussin
50x50



• LISTINO PREZZI / PRICE LIST / LISTE DES PRIX pag. 340



GIÒ style

Definisco l'architettura musica congelata.

I call architecture frozen music.

Je définis l'architecture comme de la musique figée.

Johann W. Goethe

LO SPAZIO È UN PROBLEMA?

Gestitelo con intelligenza. Scegliete un arredo che potete usare per diverse funzioni: divano durante il giorno, letto per la notte. Con Giò potete godervi la flessibilità di avere due mobili in uno, facile da convertire e che ottimizza i vostri spazi.

IS SPACE A PROBLEM?

Handle it with intelligence. Select furniture you can use for different functions: sofa during the day, bed for the night. With Giò you can enjoy the flexibility of having two pieces of furniture in one, easy to convert and optimizing your space.

L'ESPACE EST UN PROBLÈME?

Gérez-le avec intelligence. Choisissez des meubles que vous pouvez utiliser pour différentes fonctions : canapé le jour, lit durant la nuit. Avec Giò, vous pouvez profiter de la souplesse de deux meubles en un, facile à convertir et qui optimise votre espace.

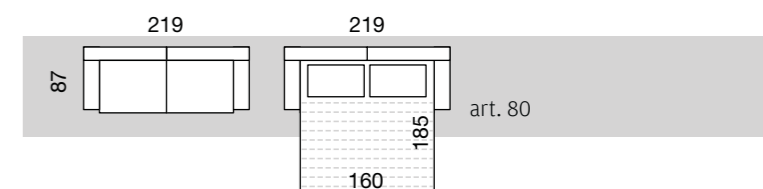



L'APERTURA FACILE

Giò è un divano letto con apertura semplificata grazie al meccanismo di rotazione della seduta che ruota senza rimuovere i cuscini.



AN EASY OPENING

Giò is a sofa bed with simplified opening thanks to the rotation mechanism that rotates the seat without removing the cushions.



OUVERTURE FACILE

Giò est un canapé-lit doté d'une ouverture simplifiée grâce au mécanisme de rotation de l'assise qui pivote sans besoin de retirer les coussins.

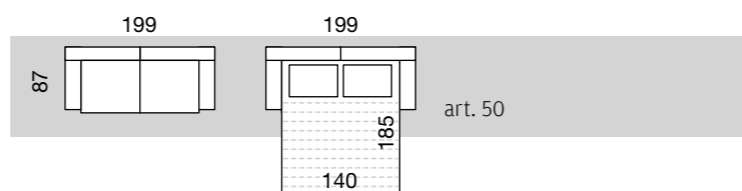

Struttura e imbottitura

Telaio in legno con parti in abete essiccato di vari spessori, agglomerato di legno da 18 mm e multistrato di pino e/o pioppo da 18 mm, in classe E1, pertanto a bassa emissione di formaldeide. Il tutto rivestito da maglia di poliestere termoaccoppiata ad espanso e/o ovatta di poliestere. Imbottitura seduta in espanso indeformabile D26NY rivestito in maglia di poliestere accoppiato a resinato da g 150 + espanso mm 3. Schienale in espanso indeformabile D30MP sempre comunque rivestito in maglia di poliestere da g 150. Bracciolo in espanso indeformabile D25N, rivestito in faldia di poliestere termolegata.

Meccanismo letto

Tubi in acciaio diametro mm 30. Meccanismi particolari stampati in acciaio. Rete elettrosaldata, filo in acciaio saldato elettricamente. Il tutto verniciato con resina epossipoliestere. Particolari in plastica in polietilene. Portata di sicurezza kg 180. Materasso a molle elicoidali a compressione, acciaio temperato C70, con imbottitura in poliuretano espanso D21P indeformabile ambo i lati, ovatta agugliata, rivestito in tela trapuntata in cotone 100%. Lunghezza cm 200 +/- 1, spessore cm 14 +/- 0,5.

Materasso

Materasso in poliuretano espanso indeformabile D25 spessore 12 cm +/- 2 cm, rivestito in poliestere e cotone su ambedue i lati.

Structure and rembourrage

Cadre en bois avec parties en sapin séché de plusieurs épaisseurs, bois aggloméré de 18 mm et multipliés de pin et/ou de peuplier de 18 mm, de classe E1, donc à basse émission de formaldéhyde. Le tout revêtu de jersey de polyester associé thermiquement à l'expansé et/ou à la ouate de polyester.

Assise en expansé indeformable D26NY revêtu de jersey de polyester associé à résine de 150 g + expansé 3 mm. Dossier en expansé indeformable D30MP mais toujours revêtu de jersey de polyester de 150 g. Accoudoirs, selon les modale, en expansé indeformable D25N, revêtu de voile de polyester associé thermiquement.

Mécanisme lit

Tubes en acier diamètre 30 mm. Mécanismes particuliers estampés en acier. Sommier électrosoudé, fil en acier soudé électriquement. Le tout peint avec une résine époxy polyester. Détails en plastique polyéthylène. Portée de sécurité 180 kg. Matelas à ressorts hélicoïdaux à compression, acier trempé C70, en rembourrage en polyuréthane expansé D21P indeformable des deux côtés, ouate aiguilletée, revêtu en toile matelassée en coton 100%. Longueur cm 200 +/- 1, épaisseur cm 14 +/- 0,5.

Matelas

Matelas en polyuréthane expansé indeformable D25 épaisseur 12 cm +/- 2 cm, revêtu de polyester et coton des deux côtés.

Structure and upholstery

Wood frame with parts in dried fir, wood chipboard of mm 18. Multilayer in pine and/or poplar of mm 18. All covered in expanded thermal coupled polyester mesh and/or polyester padding. All made from wood chips in class E1, therefore with low emission of formaldehyde.

Upholstery chair non-deformable foam rubber D26NY lined in polyester mesh coupled to g. 150 resin-treated material and mm 3 foam rubber. Back in D30MP non-deformable foam rubber always lined in g 150 polyester mesh. Armrest according to the model in non-deformable foam rubber D25N, lined in thermally laminated polyester layer.

Bed mechanism

Steel tuber diameter mm 30. Mechanism parts pressed in steel. Electro-welded base; steel wire electrically welded. All painted with epoxy-polyester resin. Safe load-bearing weight kg 180. Mattress with helicoidal compression springs, tempered steel C70, with padding in expanded polyurethane D21P non-deformable both sides, stitched padding, covered with quilted 100% cotton. Length cm 200 +/- 1, thickness cm 14 +/- 0,5. Mattress in expanded polyurethane D21P non-deformable thickness cm 12, covered with quilted 100% cotton. Length cm 200 +/- 1, thickness cm 14 +/- 0,5.

Mattress

Mattress in D25 indeformable polyurethane foam, 12 cm +/- 2 cm thickness, covered in polyester and cotton on both sides.

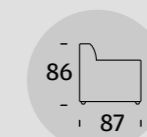

Art. 40
Divano/letto 2 posti
2-seater sofa bed
Canapé convertible
2 places

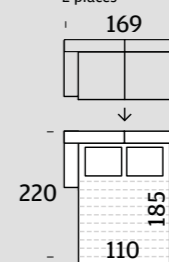

Art. 50
Divano/letto 3 posti
3-seater sofa bed
Canapé convertible
3 places

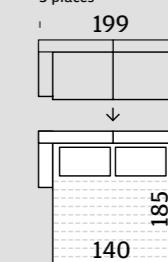

Art. 80
Divano/letto 3 posti maxi
Maxi 3-seater sofa bed
Canapé convertible
3 places maxi

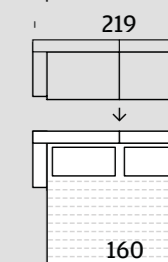

• LISTINO PREZZI / PRICE LIST / LISTE DES PRIX pag. 341

L'IDEA IN PIÙ

Un modo semplice per rendere più calda e accogliente la zona living è "vestirla" con un tappeto.

AN ADDITIONAL IDEA

An easy way to make the living area warmer and cosier is to "dress" it with a carpet.

L'IDÉE EN PLUS

Un moyen simple pour faire de la zone salon un lieu plus chaleureux et accueillant est de l'«habiller» d'un tapis.



Qualità

I dettagli fanno la differenza e da Felis ogni imbottito è progettato e prodotto per rispondere ad uno standard di qualità totale.

Quality

Details make the difference and every padded item made by Felis is designed and manufactured to meet a standard of total quality.

Qualité

Les détails font la différence et chez Felis, tous les rembourrages sont conçus et fabriqués pour répondre à une norme de qualité totale.



www.felis.it

Felis

OPLÀ style

L'architettura è vuoto, tocca a te definirlo.
Architecture is emptiness, it's up to you to define it.
L'architecture est vide, c'est à vous de la définir.

Luigi Snozzi

IL DIVANO GIOVANE

Una proposta giovane e informale che unisce la praticità del divano letto ad un'estetica accattivante ed ironica, perfetta per gli appartamenti più piccoli e adattabile ad ogni situazione. Facilmente scomponibile e ricomponibile. Oplà è facile comfort.

A YOUNG SOFA

A young and informal proposal: Oplà, with its backs and armrests placed according to their role in the composition, is perfect to be composed and decomposed any time you want.

LE CANAPÉ JEUNE

Une proposition jeune et informelle : Oplà avec dossiers et accoudoirs positionnés en fonction de leur rôle dans la composition est parfait pour une composition et décomposition aussi souvent que vous le souhaitez.



Un designer dovrebbe sapere che gli oggetti possono diventare lo strumento di un rito esistenziale.

A designer should know that objects can become the instrument of a rite of existence.

Le designer devrait savoir que les objets peuvent devenir l'instrument d'un rite existentiel.

Ettore Sottsass

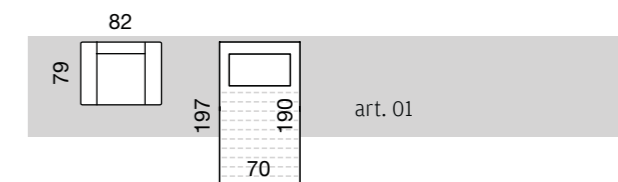
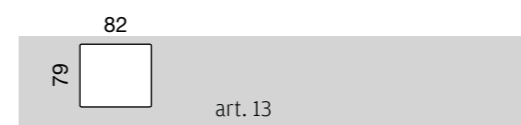

L'APERTURA A SCOMPATTAMENTO

Dopo aver sfilato il rivestimento, in poche mosse tutto è pronto. La seduta viene alzata lateralmente per permettere alla base-rete, piegata in due, di sollevarsi e distendersi, scompiattando la struttura.

Poi l'elemento seduta torna ad abbassarsi unendosi agli altri due elementi, completando il letto.

FOLD DOWN OPENING

After having removed the cover, in just a few steps, everything is ready. The seating is lifted sideways, to allow the base - folded into two - to be lifted and folded down, thus "unpacking" the structure.

Then the seat unit is pulled down again and is joined to the other two elements, thus completing the bed.

L'OUVERTURE PAR DÉCOMPACTAGE

Après avoir retiré le revêtement, tout est prêt en quelques gestes. L'assise se soulève latéralement pour permettre au sommier, plié en deux, de se soulever et de se déployer, décompactant ainsi la structure.

Puis l'assise se rabaisse et s'unit aux deux autres éléments pour devenir un lit.

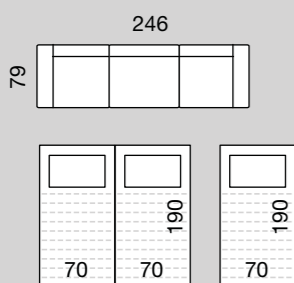

art. 1D+09+1S



Oplà a trasformazione avvenuta può ospitare fino a tre persone perché è dotato di tre letti singoli, essenziali ma confortevoli.

HOSPITALITY FOR THREE

After the transformation, Oplà can accommodate up to three people because it is equipped with three single beds, basic but comfortable.

L'HOSPITALITÉ POUR TROIS

Après sa transformation, Oplà peut accueillir jusqu'à trois personnes, car il dispose de trois lits simples, essentiels mais confortables.

Struttura e imbottitura

Struttura costituita da meccanismo letto, dove il telaio è realizzato su tubolare di ferro e rete elettrosaldata verniciata a forno con polveri epossidiche. Imbottitura schienale e bracciolo realizzati in espanso sagomato indeformabile D25 all'interno lastra in agglomerato di fibra di legno. Il tutto rivestito in resinato di poliestere 100% da 200 g accoppiato a vellutino di poliestere 100%.

Materasso

Materasso in poliuretano espanso indeformabile D25 spessore 12 cm ffl 2 cm, rivestito in poliestere e cotone.

Structure and upholstery

Structure consisting of a bed mechanism, with a frame created on iron tube and on an electrowelded base, oven coated with epoxy powder. Upholstery backrest and armrest made of shaped indeformable foam with D25. Inside, there is a sheet made of agglomerated wood fibre. The whole is covered in 100% polyester resinate, with 200 g weight, coupled to 100% polyester velveteen.

Mattress

Mattress in D25 indeformable polyurethane foam, 12 cm ffl 2 cm thickness, covered in polyester and cotton.

Structure et rembourrage

Structure constituée du mécanisme du lit, où le cadre est réalisé sur le tubulaire de fer et le sommier électrosoudé peint au four aux poudres époxy. Rembourrage dossier et accoudoirs réalisés en expansé façonné indeformable D25 à l'intérieur plaque en aggloméré de fibre de bois. Le tout revêtu de résine de polyester 100% de 200 g associée au velours de polyester 100%.

Matelas

Matelas en polyuréthane expansé indeformable D25 épaisseur 12 cm ffl 2 cm, revêtu de polyester et coton.

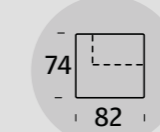

Art. 01
Poltrona/Letto
Chair bed
Fauteuil convertible

82



197

190



70

Art. 1D-1S
Laterale/letto 1 posto
RH-LH 1-seater side el.
Canapé bâtarde 1 place D-G

82

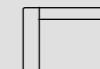

197

190

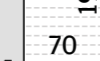

70

Art. 09
Elemento centrale
Central element
Chausseuse

82



197

190



70

Art. 13
Pouf
Pouf

82



197

190



70

• LISTINO PREZZI / PRICE LIST / LISTE DES PRIX pag. 342

OSPITALITÀ PER TRE



POUF style

I bambini sono divertenti proprio perché si possono divertire con poco.

Children are fun because they can have fun with very little.

Les enfants sont amusants car ils savent s'amuser avec très peu.

Hugo Von Hofmannsthal



Con i pouf sagomati crea delle fantasiose composizioni accostando più elementi insieme.

With different shape pouf you can create imaginative compositions by combining multiple items together.

Avec les poufs à formes, vous créez des compositions originales en combinant ensemble plusieurs éléments.

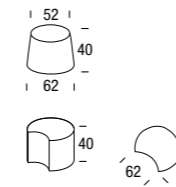

PLAY DESIGN

Pratico e versatile, giocoso e colorato, il pouf è un complemento d'arredo adatto ad ogni ambiente. Ricco di personalità può essere abbinato come seduta ad un sistema di divani, trasformandosi in un utile piano d'appoggio.

Practical and versatile, playful and colourful, the pouf is a piece of furniture suitable for any environment. Full of personality, it can be combined to a sofa system as a seat, becoming a useful support surface.

Pratique et versatile, ludique et coloré, le pouf est un meuble adapté à n'importe quel espace. Riche en personnalité, il peut être associé sous forme de siège à un système de canapés, se transformant ainsi en un plan d'appui très utile.

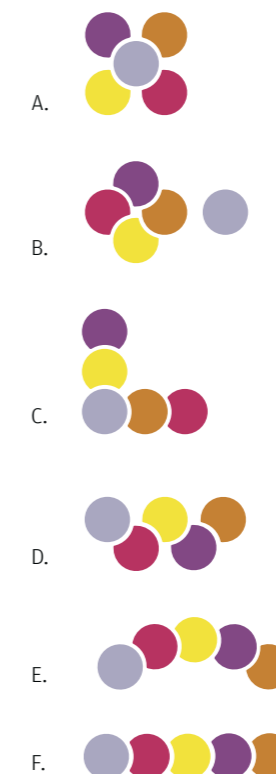

UNA SEDUTA IN PIU'



Pouf con cordoncino di rifinitura a contrasto.

Pouf with contrasting finishing cord.

Pouf avec bordures de finition de couleur différente.



Solitamente viene posizionato davanti al divano per essere utilizzato come poggiatesta, ma il pouf può trovar posto anche in un angolo, senza che dia fastidio, per arredare con stile una zona un po' più defilata del soggiorno, magari di passaggio, trasformandosi quando è necessario in una seduta aggiuntiva adatta ad incontri amichevoli ed informali.

AN EXTRA SEAT

It is usually placed in front of the couch to be used as a footrest, but an pouf can also find its place in a corner, without being a bother, to furnish a more secluded area of the living-room with style, perhaps temporarily, turning, when necessary, into an additional seat, suitable for friendly and informal meetings.

UNE PLACE EN PLUS

Il est habituellement placé devant le canapé pour être utilisé comme repose-pieds, mais le pouf peut également trouver sa place dans un coin, sans déranger, pour meubler avec style une zone un peu plus en retrait du salon, peut-être de passage, pour devenir le cas échéant un siège supplémentaire dans le cadre de réunions entre amis et informelles.

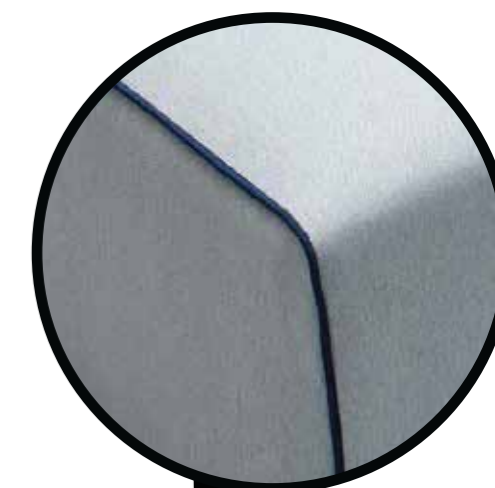



IMMANCABILE POUF

Un pouf è un complemento d'arredo assolutamente originale, attuale e versatile che non può davvero mancare in un soggiorno, perché è capace di sintetizzare diverse funzioni in un unico oggetto, garantendo il minimo ingombro insieme al massimo della praticità.

INEVITABLE POUF

An pouf is a completely original, modern and versatile piece of furniture that cannot really be missing in a living room, because it is capable of synthesizing various functions into a single object, using little space and giving lots of convenience.

L'INÉVITABLE POUF

Un pouf est un meuble tout à fait original, moderne et versatile qui ne peut pas vraiment manquer dans un salon. En effet, il réussit à synthétiser les différentes fonctions en un seul objet, il est peu encombrant et hautement pratique.



POUF MANIA

A.

B.

C.

D.

Fai diventare il pouf protagonista dell'intero salotto, imprimendogli uno stile inconfondibile ed una personalità unica.

Make the pouf the protagonist of the entire living room, giving it a unique style and a unique personality.

Donnez au pouf le rôle principal dans le salon, pour lui donner un style inconfondable et une personnalité unique.



THE STAR OF THE LIVING AREA

Nessun posto è bello come casa mia.

There's no place like home.

Aucun endroit n'est aussi beau que chez moi. - Dorothy Gale



Quando hai bisogno di far ordine,
il pouf con contenitore è un'ottima
soluzione.

When you need to tidy up,
an pouf with a storage
compartment is a great solution.

Lorsque le rangement s'impose,
le pouf avec conteneur est une
excellente solution.

Optional con
ruote pivotanti

Optional with
castor wheels

En option avec
roulettes pivotantes



DI TUTTE LE FORME

Quando diciamo che ne abbiamo di ogni, non
esageriamo. Scegli il pouf che fa per te: tinta
unita, fantasia, con o senza contenitore.
Il pouf è la soluzione easy per tutti gli spazi.

IN ALL SHAPES

When we say that we have them all,
we are not exaggerating. Choose the
pouf for you: plain, patterned, with or
without storage. The pouf is the easy
solution for all spaces.

DE TOUTES LES FORMES

Quand nous disons que nous les avons
toutes, nous n'exagérons pas. Choisissez le
pouf qui vous convient le mieux :
couleur unie, à motifs, avec ou sans
rangement. Le pouf est la solution facile
pour tous les espaces.



CUSHIONS style



*
 Cuscino con bordo a contrasto
 Cushion with contrasting border
 Coussin avec bordure contrastante

DESIGN È DI STOFFA
 Di cuscini ne esistono davvero "di tutti i colori", di forme particolari, di migliaia di fantasie diverse e rivestiti in tessuti d'ogni tipo; possono essere grandi, enormi o anche piccolissimi; più o meno morbidi, piuttosto che rigidi; di tipo classico, moderno, etnico o orientaleggiante. Trasforma il tuo soggiorno in un tripudio fashion e glamour con i tessuti.

DESIGNER FABRIC
 Cushions can really be "of all colours", with special shapes, thousands of different patterns, and coated with fabrics of any kind; they may be large, huge, or even very small, more or less soft, rather than rigid; classic, modern, ethnic, or oriental. Turn your living room into something fashionable and glamor through fabrics.

LE DESIGN EST EN TISSU
 Des coussins, nous en avons véritablement «de toutes les couleurs», de formes particulières, avec des milliers de motifs et des revêtements en tissu de tout type. Ils peuvent être grands, énormes ou très petits, plus ou moins moelleux, plutôt que rigides, de style classique, moderne, ethnique ou oriental. Transformez votre salon en un lieu de jubilation fashion et glamour avec les tissus.



Passione

Ogni imbottito Felis comunica la passione del saper fare e la ricerca della qualità e del comfort ottimale.

Passion

Each padded item made by Felis communicates the passion of our know-how and our pursuit of quality and comfort.

Passion

Chaque meuble rembourré Felis transmet la passion de savoir-faire et la recherche de la qualité et du confort.



Felis elegance.

www.felis.it



Felis

LA QUALITÀ DELL'AUTENTICO MADE IN ITALY

THE QUALITY OF AUTHENTIC MADE IN ITALY
LA QUALITÉ DE L'AUTHENTIQUE MADE IN ITALY



TRADIZIONE ARTIGIANALE

Noi abbiamo un tesoro: la cultura del saper fare, quel sapere artigianale che rende ogni nostro prodotto esteticamente più bello ma anche più duraturo nel tempo.

ARTISAN TRADITION

We have a treasure: the culture of know-how, knowledge, and craftsmanship that helps every product look nicer but also be more durable.

TRADITION ARTISANALE

Nous avons un trésor : la culture du savoir-faire, le savoir-faire artisanal qui rend chacun de nos produits plus beau mais également plus durable.

Solo made in Italy

Felis produce internamente l'imbottito al 100%: una scelta controcorrente, per garantire una qualità rigorosamente made in Italy.

Solo materiali certificati

Ogni divano è realizzato in Italia con una grande attenzione al dettaglio. Dai fusti alle imbottiture, Felis impiega solo materiali certificati, di prima scelta, all'interno di severe procedure produttive.

Solo eccellenza

Felis ti offre un prodotto sicuro e comodo. Con un rapporto qualità-prezzo eccellente.

Only made in Italy

Felis produces 100% of the internal padding, a choice against the current, to ensure high quality made in Italy.

Only certified materials

Each sofa is made in Italy with great attention to detail. From frames to padding, Felis employs only certified materials, high-grade, within strict production procedures.

Only excellence

Felis offers a safe and comfortable product. With an excellent price-quality ratio

Made in Italy uniquement

Felis produit l'intégralité du rembourrage de ses meubles: un choix à contre-courant permettant de garantir une qualité exemplaire strictement Made in Italy.

Matériaux certifiés uniquement

Tous les canapés sont fabriqués en Italie avec une grande attention accordée aux détails. Des socles aux rembourrages, Felis utilise uniquement des matériaux certifiés, de haute qualité, travaillés selon de strictes procédures de production.

L'excellence uniquement

Felis vous propose un produit sûr et pratique. Avec un excellent rapport qualité-prix



DA 20 ANNI NE FACCIAMO DI TUTTI I COLORI

WE HAVE BEEN USING ALL KINDS OF COLOURS FOR 20 YEARS
DEPUIS 20 ANS, NOUS EN FAISONS DE TOUTES LES COULEURS

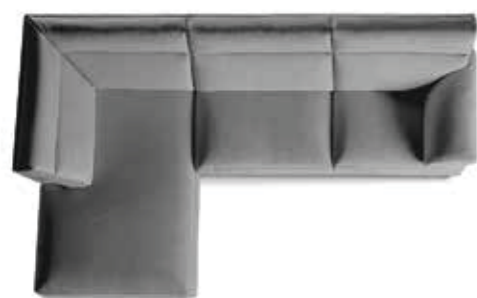

Tutti i modelli su
All models on
Tous les modèles sur
www.felis.it

LA SOLIDITÀ E
IL COMFORT
DELL'ECCELLENZA
ITALIANA

La nostra storia

Una tradizione artigianale da oltre 20 anni: Felis realizza un'ampia gamma di imbottiti che rispondono a standard rigorosi ed elevati.

THE STRENGTH
AND COMFORT
OF ITALIAN
EXCELLENCE

Our history

A tradition of craftsmanship for over 20 years: Felis manufactures a wide range of upholstered furniture that meet rigorous and high standards.

LA SOLIDITÉ ET
LE CONFORT DE
L'EXCELLENCE
ITALIENNE

Notre histoire

La tradition artisanale depuis plus de 20 ans: Felis réalise une vaste gamme de meubles rembourrés répondant à des normes rigoureuses et élevées.

LA NOSTRA PASSIONE PER I TESSUTI

OUR PASSION FOR THE FABRICS
NOTRE PASSION POUR LES TISSUS



STILE, QUALITÀ E TRADIZIONE

Il nostro punto di forza

Il nostro punto di forza sono i tessuti, realizzati in collaborazione con le migliori industrie tessili italiane, con una particolare attenzione verso i filati, le trame e i disegni per poterti offrire una gamma sempre attuale.

STYLE, QUALITY AND TRADITION

Our strong point

Our strength lies in the fabrics, made in collaboration with the best Italian textile industries, with a particular focus on the yarns, textures, and designs, to be able to offer an ever present range.

STYLE, QUALITÉ ET TRADITION

Notre point fort

Notre force réside dans les tissus, fabriqués en collaboration avec les meilleures industries textiles italiennes, avec une attention particulière pour les fils, les textures et les motifs, pour une gamme toujours actuelle.

FELIS COLOR TRENDS

Se sfogliate le pagine di questo magazine, troverete un comune denominatore: tutti i colori sono sobri, neutri, morbidi, avvolgenti. Questo è il Felis Style. Ma se preferite personalizzare il vostro soggiorno senza badare troppo a mode e tendenze, non dovrete far altro che scegliere tra le oltre 750 varianti di colori e fantasie messe a disposizione da Felis. Perché con Felis tutto è possibile.

FELIS COLOR TRENDS

If you flip through the pages of this magazine, you will find a common denominator: all colours are sober, neutral, soft and enveloping. This is the Felis Style. But if you prefer to customize your living-room without paying much attention to fashions and trends, all you have to do is choose one among the more than 750 variations of colours and patterns provided by Felis. Because with Felis everything is possible.

FELIS COLOR TRENDS

En feuilletant les pages de ce magazine, vous trouverez un dénominateur commun: toutes les couleurs sont sobres, neutres, douces et enveloppantes. C'est ce que nous appelons le Felis Style. Mais si vous préférez personnaliser votre séjour sans prêter trop attention aux modes et aux tendances, il vous suffit tout simplement de choisir parmi les 750 variantes de couleurs et de motifs proposées par Felis. Car avec Felis, tout est possible.

Tutti i colori su
All colours on
Toutes les couleurs sur
www.felis.it

LE 2 TIRELLE STYLE: SUPER & LUSO

2 COLOUR SAMPLES BY STYLE: SUPER & LUSO

LE 2 TRINGLES STYLE : SUPER ET LUXE



Gioca ad "amalgamare" razionalità e istinto, realtà e immaginazione, per arredare con gusto la tua casa di tessuto. Richiedi al tuo rivenditore di fiducia le tirelle Lusso e Super, specifiche per il programma Style: dalla microfibra alle fibre naturali e moltissime sfumature di colore. In più potrai anche scegliere tra i tessuti tecnologici antimacchia idrorepellenti, che fanno scivolare via i liquidi.

Play to "mix" rationality and instinct, reality and imagination, to decorate your house with fabrics, with taste. Ask your dealer for the Super and Lusso colour samples, specific for the Style program: from microfiber to natural fibres and various shades of colour. Moreover, you can also choose between the stain-proof and water-repellent technological fabrics, which slide off liquids.

Jouer à mélanger la rationalité et l'instinct, la réalité et l'imagination, pour meubler avec goût votre maison de tissu. Demandez à votre distributeur les tringles Luxe et Super, spécialement conçues pour le programme Style: des microfibres aux fibres naturelles en passant par de nombreuses nuances de couleur. De plus, vous pourrez également choisir entre les tissus technologiques anti-tache hydrofuges, sur lesquels glissent les liquides.

A TE LA SCELTA

Il colore è fondamentale

nella progettazione degli ambienti domestici. E si sa, a seconda della personalità, ognuno ha il suo colore preferito e le sue idee in fatto di abbinamenti. Potrai scegliere tra una palette infinita di colori: dai toni più intensi e carichi a quelli naturali, da quelli fluo per ambienti creativi e giovanili a quelli classici arricchiti da fantasie e decori.

THE CHOICE IS YOURS

Colours are critical

in the design of home environments. And, as we know, everyone has their own favourite colours and their own ideas in terms of combinations, depending on their own personality. You can choose between an infinite palette of colours: from more intense and strong shades, to natural ones; from fluorescent ones for creative environments for young people, to classic patterns embellished with decorations.

À VOUS DE CHOISIR

La couleur est fondamentale

dans la conception des espaces domestiques. Et il est bien connu que, en fonction de notre personnalité, nous avons tous notre couleur préférée et nos idées de combinaisons. Vous pourrez choisir parmi une palette infinie de couleurs : des tons les plus intenses et vifs à ceux plus naturels ou fluorescents, pour des ambiances créatives et jeunes ou classiques et riches de motifs et de décorations.



